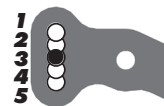
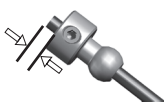
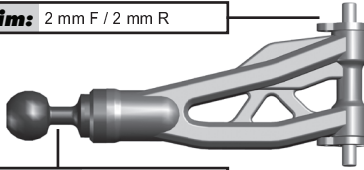
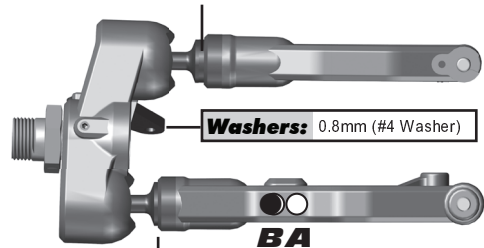

Front Suspension:

Ride Height: 27 mm
Camber: N/A
Toe: +3 (Tie Rod Gap = 22 mm)
Anti-Roll Bar
Size: 2.3 mm (Black)
Gap: 1.5 mm
Ackerman
Notes: #81063 FT Steering Block Arm +2 Deg, Aluminum
Drive Shaft: CVAs: <input checked="" type="checkbox"/> Universals: <input type="checkbox"/>
Chassis Brace: Short: <input checked="" type="checkbox"/> Long: <input type="checkbox"/>
Hex: #81079 Wheel Hex, 1 mm
Notes: #81028 FT Carbon Fiber Shock Tower #81092 FT Aluminum Steering Bellcrank Posts #81327 FT Aluminum CVA Axle

Caster Shim: 2 mm F / 2 mm R

Upper Ball Type: #81067 Steel

Upper Ball Shim: 0

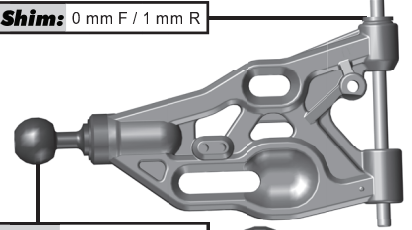
Washers: 0.8mm (#4 Washer)

Lower Ball Shim: 0

Wheelbase Shim: 0 mm F / 1 mm R

Lower Ball Type: #81067 Steel

Upper Arm Mount:
Arm Mount A:
Arm Mount B:

Rear Suspension:

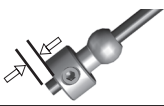
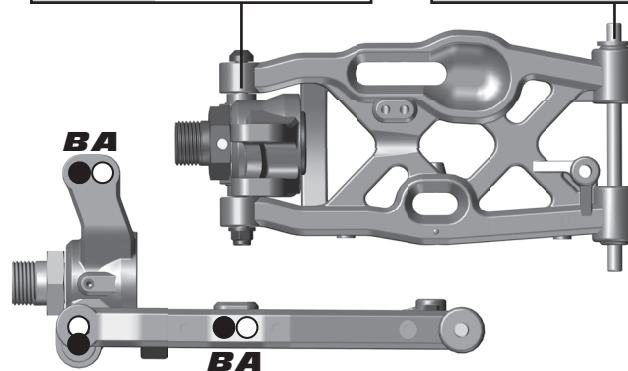
Ride Height: 27 mm
Camber: -2* (Tierod Gap = 16.5 mm)
Anti-Roll Bar
Size: 2.5 mm (White)
Gap: 2 mm (Ball Reversed)
Drive Shaft: CVAs: <input checked="" type="checkbox"/> Universals: <input type="checkbox"/>
Chassis Brace: Short: <input checked="" type="checkbox"/> Long: <input type="checkbox"/>
Hex: #81079 Wheel Hex, 1 mm
Notes: #81327 FT Aluminum CVA Axle

Hub Shim: 2.5 mm F / 2.5 mm R

Wheelbase Shim: 0 mm F / 1 mm R

Arm Mount C:
Arm Mount D:

Electronics and Engine:

Radio: Sanwa M12S
Receiver Battery: #304 Reedy 1600 mAh
Throttle Servo: #27107 Reedy RT2207A
Steering Servo: #27107 Reedy RT2207A
EPA: Throttle: N/A % Brake: N/A %
Brake Bias: 55% F / 45% R D/R: 100 %
Engine: O.S. B2101 Temp: 250F
Muffler: O.S. 2090 Fuel: VP Powermaster 30%
Restrictor: 6 mm Glow Plug: O.S. P3
Notes:

Differential:

	Fluid	Gear Set	Planet O-Rings
Front:	5,000	HTC	0
Center:	5,000	HTC	0
Rear:	3,000	HTC	0

Clutch and Gearing:

Spur Gear: 46	Bell: 13
Shoes: 2 x #81402 Composite + 2 x #81375 Aluminum	
Springs: 2 x 0.95 (Green) + 2 x 1.05 (Silver)	
Notes:	

Shocks:

	Front	Rear
Piston:	8 x 1.2 Tapered	8 x 1.3 Tapered
Fluid:	47.5 wt	45 wt
Cap:	Bleeder	Bleeder
Rebound:	0	0
Spring:	White V2	White V2
Free Length:	104 mm	121.5 mm
Notes:	#81174 & #81177 FT Chrome Shock Shafts; #81407 FT Shock Seal Bushing Set	

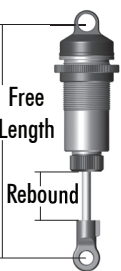

Track Info:

Size: Small <input type="checkbox"/> Medium <input type="checkbox"/> Large <input checked="" type="checkbox"/> Extra Large <input type="checkbox"/>
Surface: Dirt <input checked="" type="checkbox"/> Carpet <input type="checkbox"/> Astroturf <input type="checkbox"/> Multi Surface <input type="checkbox"/>
Traction: Low <input type="checkbox"/> Medium <input checked="" type="checkbox"/> High <input type="checkbox"/> Very High <input type="checkbox"/>
Moisture: Dry <input checked="" type="checkbox"/> Damp <input checked="" type="checkbox"/> Wet <input checked="" type="checkbox"/>
Condition: Indoor <input type="checkbox"/> Outdoor <input checked="" type="checkbox"/> Dusty <input checked="" type="checkbox"/> Hard Packed <input checked="" type="checkbox"/> Bumpy <input checked="" type="checkbox"/> Grooved <input checked="" type="checkbox"/> Smooth <input checked="" type="checkbox"/> Loamy <input checked="" type="checkbox"/>
Temperature: Ambient: 70F - 90F Track: 75F - 95F
Notes:

Tires:

Front Tires: Pro-Line Holeshot
Front Compound: M3 or X3
Front Insert: Pro-Line Closed Cell
Rear Tires: Pro-Line Holeshot
Rear Compound: M3 or X3
Rear Insert: Pro-Line Closed Cell
Wheel (F/R): #89297 Team Associated 83mm
Notes:

Body, Wings:

Body: #81110 Team Associated Kit
Wings: #81106 Team Associated Kit
Wing Height: High: <input checked="" type="checkbox"/> Low: <input type="checkbox"/>
Gap to Tower: Stock Holes
Weight:
Total Vehicle Weight: 3340g
Notes:

Vehicle Comments:

Notes: #81274 Upper Titanium Screw Kit; Kit engine mount