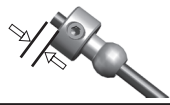
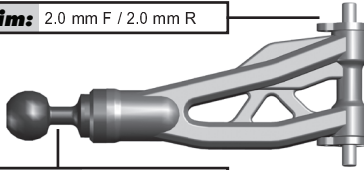
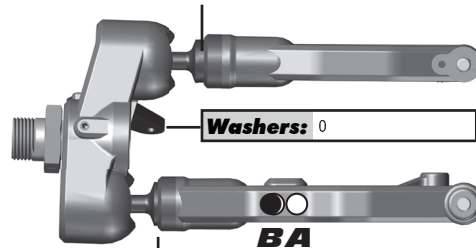

RESET

Front Suspension:

Ride Height: 15 mm
Camber: -1.5°
Toe: +1.5°
Anti-Roll Bar
Size: 2.5 mm (White)
Gap: 1.5 mm
Ackerman
Notes: #81063 FT Steering Block Arm +2 Deg, Aluminum
Drive Shaft: CVAs: <input checked="" type="checkbox"/> Universals: <input type="checkbox"/>
Chassis Brace: Short: <input checked="" type="checkbox"/> Long: <input type="checkbox"/>
Hex: #81079 Wheel Hex, +1 mm
Notes: #81028 FT Carbon Fiber Shock Tower #81085 FT Servo Saver Arm, Aluminum

Caster Shim: 2.0 mm F / 2.0 mm R

Upper Ball Type: #81067 Steel

Upper Ball Shim: 0

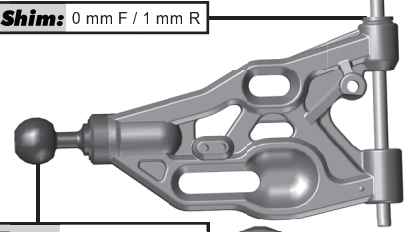
Washers: 0

BA
Lower Ball Shim: 0

Wheelbase Shim: 0 mm F / 1 mm R

Lower Ball Type: #81067 Steel

Upper Arm Mount:

Arm Mount A:

Arm Mount B:

Rear Suspension:

Ride Height: 30 mm
Camber: -1.5°
Anti-Roll Bar
Size: 2.7 mm (Blue)
Gap: 1 mm
Drive Shaft: CVAs: <input checked="" type="checkbox"/> Universals: <input type="checkbox"/>
Chassis Brace: Short: <input type="checkbox"/> Long: <input checked="" type="checkbox"/>
Hex: #81079 Wheel Hex, +1 mm
Notes: #81029 FT Carbon Fiber Shock Tower

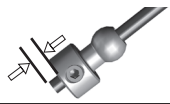
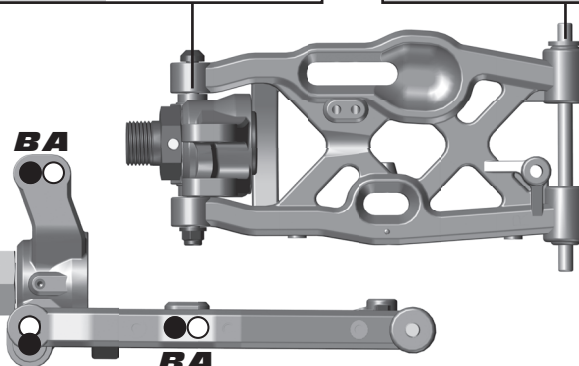
Hub Shim: 2.5 mm F / 2.5 mm R

BA
Wheelbase Shim: 1 mm F / 0 mm R

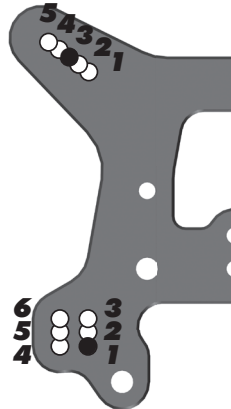
Arm Mount C:

Arm Mount D:

Electronics and Engine:

Radio: Sanwa Exzes Z
Receiver Battery: #LRP430351 LRP 2500
Throttle Servo: Futaba S9353HV
Steering Servo: Futaba S9353HV
EPA: Throttle: 55 % Brake: 50 %
Brake Bias: 50% F / 50% R D/R: 100 %
Engine: LRP ZZ.21C SQ Temp: 240F
Muffler: LRP Screamer-93 Fuel: RunnerTime 25%
Restrictor: N/A Glow Plug: LRP WT-3
Notes: #1367 FT Aluminum Clamping Servo Horn 23T, 20mm

Differential:

	Fluid:	Gear Set:	Planet O-Rings:
Front:	6,000	HTC	0
Center:	7,000	HTC	0
Rear:	3,000	HTC	0

Clutch and Gearing:

Spur Gear: 46	Bell: 13
Shoes: 3 x Aluminum	
Springs: 3 x 0.95	
Notes:	

Shocks:

	Front	Rear
Piston:	8 x 1.2 Tapered	8 x 1.3 Tapered
Fluid:	47.5 wt	45 wt
Cap:	FastRace	FastRace
Rebound:	10 mm	10 mm
Spring:	Green V2	Gray V2
Free Length:	107 mm	122.5 mm
Notes:	#81174 & #81175 FT Chrome Shock Shafts; #81164 & #81165 Fox Shock Bodies	

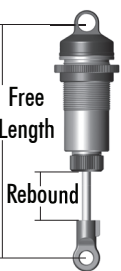

Track Info:

Size: Small <input type="checkbox"/> Medium <input type="checkbox"/> Large <input checked="" type="checkbox"/> Extra Large <input type="checkbox"/>
Surface: Dirt <input checked="" type="checkbox"/> Carpet <input type="checkbox"/> Astroturf <input type="checkbox"/> Multi Surface <input type="checkbox"/>
Traction: Low <input type="checkbox"/> Medium <input type="checkbox"/> High <input checked="" type="checkbox"/> Very High <input type="checkbox"/>
Moisture: Dry <input checked="" type="checkbox"/> Damp <input type="checkbox"/> Wet <input type="checkbox"/>
Condition: Indoor <input checked="" type="checkbox"/> Outdoor <input type="checkbox"/> Dusty <input type="checkbox"/> Hard Packed <input checked="" type="checkbox"/> Bumpy <input checked="" type="checkbox"/> Grooved <input type="checkbox"/> Smooth <input type="checkbox"/> Loamy <input type="checkbox"/>
Temperature: Ambient: 60F Track: 60F
Notes: Track was bumpy for Neo

Tires:

Front Tires: AKA Typo
Front Compound: Clay
Front Insert: AKA Red Closed Cell
Rear Tires: AKA Typo
Rear Compound: Clay
Rear Insert: AKA Red Closed Cell
Wheel (F/R): AKA
Notes:

Body, Wings:

Body: JConcepts S3
Wing: JConcepts Hybrid Lexan (No Gurney)
Wing Height: High: <input checked="" type="checkbox"/> Low: <input type="checkbox"/>
Gap to Tower: 16 mm
Weight:
Total Vehicle Weight: 3416g
Notes: 30g Under Center Rear Driveline

Vehicle Comments:

Notes: All steel screws; Loose servo saver; Kit engine mount