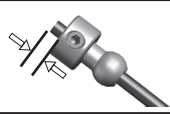
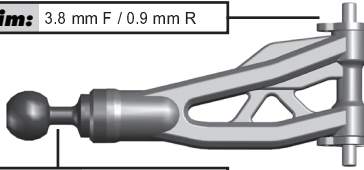
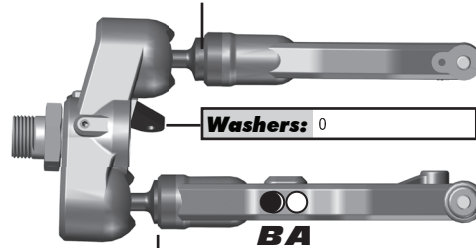

RESET

Front Suspension:

Ride Height: 25 mm
Camber: -1°
Toe: +3°
Anti-Roll Bar
Size: 2.4 mm (Green)
Gap: 2 mm
Ackerman
Notes: #81063 FT Steering Block Arm +2 Deg, Aluminum
Drive Shaft: CVAs: <input checked="" type="checkbox"/> Universals: <input type="checkbox"/>
Chassis Brace: Short: <input checked="" type="checkbox"/> Long: <input type="checkbox"/>
Hex: #81079 Wheel Hex, +1 mm
Notes: #81028 FT Carbon Fiber Shock Tower #81085 FT Servo Saver Arm, Aluminum

Caster Shim: 3.8 mm F / 0.9 mm R

Upper Ball Type: #81068 Aluminum

Upper Ball Shim: 0

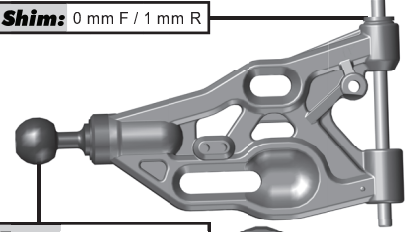
Washers: 0

BA
Lower Ball Shim: 0

Wheelbase Shim: 0 mm F / 1 mm R

Lower Ball Type: #81068 Aluminum

Upper Arm Mount:

Arm Mount A:

Arm Mount B:

Rear Suspension:

Ride Height: 28 mm
Camber: -1.5°
Anti-Roll Bar
Size: 2.6 mm (Gray)
Gap: 0 mm
Drive Shaft: CVAs: <input checked="" type="checkbox"/> Universals: <input type="checkbox"/>
Chassis Brace: Short: <input type="checkbox"/> Long: <input checked="" type="checkbox"/>
Hex: #81079 Wheel Hex, +1 mm
Notes: #81029 FT Carbon Fiber Shock Tower

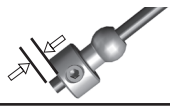
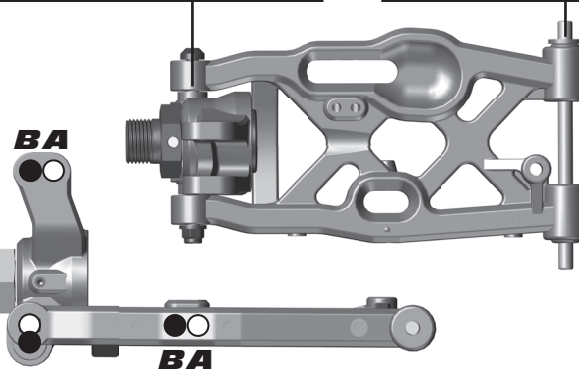
Hub Shim: 2.5 mm F / 2.5 mm R

Wheelbase Shim: 1 mm F / 0 mm R

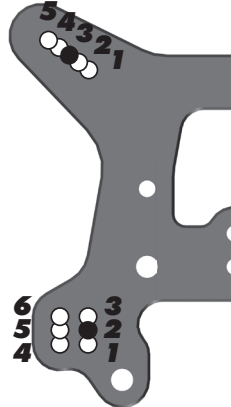
Arm Mount C:

Arm Mount D:

Electronics and Engine:

Radio: Sanwa M12S
Receiver Battery: #308 Reedy 1600 mAh
Throttle Servo: Savox
Steering Servo: Savox
EPA: Throttle: 54 % Brake: 53 %
Brake Bias: 52% F / 48% R D/R: 100 %
Engine: Mx B2101 Temp: 240F
Muffler: O.S. 2090 Fuel: Mx 25%
Restrictor: 6.0 mm Glow Plug: O.S. P3
Notes: #1361 FT Aluminum Servo Horn, 18.5mm

Differential:

	Fluid:	Gear Set:	Planet O-Rings:
Front:	7,000	HTC	0
Center:	10,000	HTC	0
Rear:	3,000	HTC	0

Clutch and Gearing:

Spur Gear: 46	Bell: 14
Shoes: 1 x Carbon + 2 x Soft Aluminum	
Springs: 3 x 1.0	
Notes:	

Shocks:

	Front	Rear
Piston:	8 x 1.3 Flat	8 x 1.3 Tapered
Fluid:	42.5 wt	32.5 wt
Cap:	Emulsion	Emulsion
Rebound:	0 mm	0 mm
Spring:	Grey V2	Grey V2
Free Length:	104 mm	122.5 mm
Notes:	#81174 & #81175 FT Chrome Shock Shafts; #81164 & #81165 Fox Shock Bodies; #81407 FT Shock Seal Bushing	
Set		

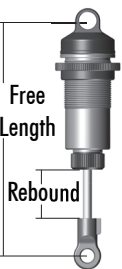

Track Info:

Size: Small <input type="checkbox"/> Medium <input type="checkbox"/> Large <input checked="" type="checkbox"/> Extra Large <input type="checkbox"/>
Surface: Dirt <input checked="" type="checkbox"/> Carpet <input type="checkbox"/> Astroturf <input type="checkbox"/> Multi Surface <input type="checkbox"/>
Traction: Low <input type="checkbox"/> Medium <input type="checkbox"/> High <input checked="" type="checkbox"/> Very High <input type="checkbox"/>
Moisture: Dry <input checked="" type="checkbox"/> Damp <input type="checkbox"/> Wet <input type="checkbox"/>
Condition: Indoor <input checked="" type="checkbox"/> Outdoor <input type="checkbox"/> Dusty <input type="checkbox"/> Hard Packed <input checked="" type="checkbox"/> Bumpy <input checked="" type="checkbox"/> Grooved <input type="checkbox"/> Smooth <input type="checkbox"/> Loamy <input type="checkbox"/>
Temperature: Ambient: 60F Track: 60F
Notes: Track was bumpy for Neo

Tires:

Front Tires: JConcepts Barcodes
Front Compound: Gold
Front Insert: JConcepts Dirt Tech
Rear Tires: JConcepts Barcodes
Rear Compound: Gold
Rear Insert: JConcepts Dirt Tech
Wheel (F/R): JConcepts Mono
Notes:

Body, Wings:

Body: JConcepts S3
Wings: #81108 Team Associated Kit / JConcepts Front Scoop
Wing Height: High: <input checked="" type="checkbox"/> Low: <input type="checkbox"/>
Gap to Tower: Stock Location
Weight:
Total Vehicle Weight: ~3370g
Notes:

Vehicle Comments:

Notes: #81274 Upper Titanium Screw Kit; Kit engine mount