

Front Suspension:

RESET
Ride Height: 25 mm (Body Off + Full Tank)

Camber: N/A

Toe: Tierod Gap = 22.6 mm

Anti-Roll Bar
Size: 2.3 mm (Black)

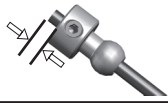
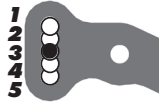
Gap: 2 mm

Ackerman
Notes: Steering Block Arm
 Raised 0.7 mm; 0.7 mm Under
 Inner Steering Link On Rack

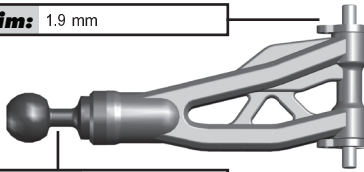
Drive Shaft: CVAs: Universals:
Chassis Brace: Short: Long:
Hex: #81079, RC8B3 +1 mm

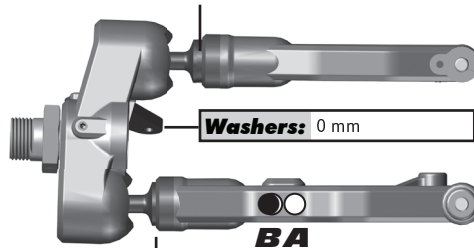
Notes: #81026 Aluminum Shock Tower; #81063 FT
 RC8B3 Steering Block Arms, +2; #81085 FT Servo Saver
 Arm, Aluminum

Caster Shim: 1.9 mm

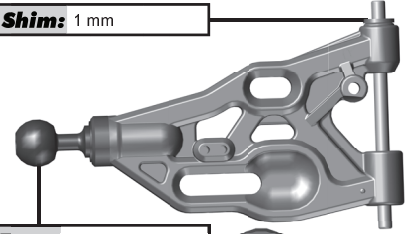
Upper Ball Type: #81068 Aluminum

Upper Ball Shim: 2.1 mm

Washers: 0 mm

BA
Lower Ball Shim: 0 mm

Wheelbase Shim: 1 mm

Lower Ball Type: #81068 Aluminum

Upper Arm Mount:

Arm Mount A:

Arm Mount B:

Rear Suspension:

Ride Height: 29 mm (Body Off + Full Tank)

Camber: -1

Anti-Roll Bar
Size: 2.5 mm (White)

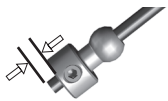
Gap: 0

Drive Shaft: CVAs: Universals:
Chassis Brace: Short: Long:
Hex: #81079, RC8B3 +1 mm

Notes: #81422 FT Graphite Rear Shock Tower, Tall

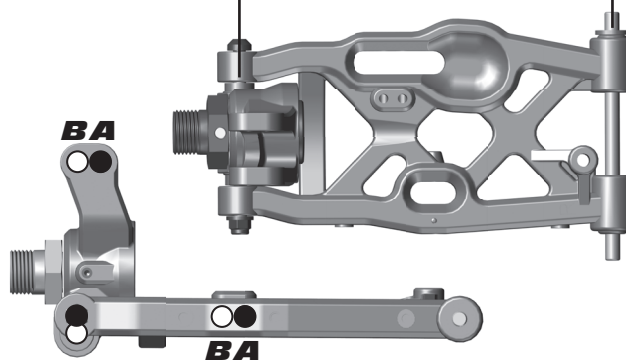
Hub Shim: 2.5 mm R / 2.5 mm F

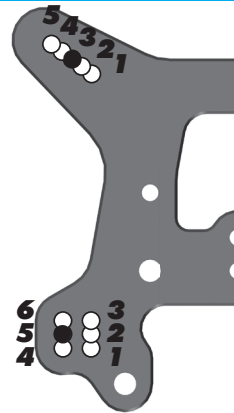
Wheelbase Shim: 1 mm

BA
BA
Arm Mount C:

Arm Mount D:

Electronics and Engine:

Radio: Futaba 7px

Receiver Battery: Protek 2300

Throttle Servo: Savox SB- 2290

Steering Servo: Savox SB- 2290

EPA: Throttle: N/A % Brake: N/A %

Brake Bias: 50/50

D/R: 100 %

Engine: MX

Temp: N/A

Muffler: MX

Fuel: MX

Restrictor: 6.5 mm

Glow Plug: MX

Notes: Low Head

Differential:

	Fluid	Gear Set	Planet O-Rings
Front:	10,000	HTC	N/A
Center:	7,000	HTC	N/A
Rear:	5,000	HTC	N/A

Clutch and Gearing:

Spur Gear: 46T **Bell:** 13T

Shoes: 4 x #81375 Aluminum

Springs: 2 x #81367 1.0 mm

Notes: #81009 Underdrive Gearing Front & Rear (42/12)

Shocks:

	Front	Rear
Piston:	3x1.35+3x1.45 Flat	3x1.35+3x1.5 Flat
Fluid:	#5430 FT 45 wt	#5423 FT 40 wt
Cap:	#81179 Bleeder	#81179 Bleeder
Rebound:	0 mm	0 mm
Spring:	#81225 Blue	#81230 Gray
Free Length:	105 mm	117 mm

Notes: #81407 Machined Shock Internals; MIP Mugen

Bypass Pistons (Green Front / Blue Rear Flap)

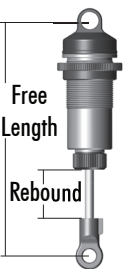

Track Info:

Size: Small Medium Large Extra Large
Surface: Dirt Carpet Astroturf Multi Surface
Traction: Low Medium High Very High
Moisture: Dry Damp Wet
Condition: Indoor Outdoor Dusty Hard Packed
 Bumpy Grooved Smooth Loamy
Temperature: Ambient: 95F Track:

Notes:

Tires:

Front Tires: JConcepts Stalkers

Front Compound: Blue

Front Insert: JConcepts Dirt Tech

Rear Tires: JConcepts Stalkers

Rear Compound: Blue

Rear Insert: JConcepts Dirt Tech

Wheel (F/R): JConcepts

Notes:

Body, Wings:

Body: JConcepts S15

Wing: HB

Wing Height: High: Low:
Gap to Tower: Kit

Weight:

Total Vehicle Weight:
Notes: #81406 FT Chassis Weight, 30g (Rear)

Vehicle Comments:

Notes: #81274 FT Upper Titanium Screw Kit; #81382 FT Differential Cross Pins, With Inserts; Servo Speed -25 Forward and Return; ProTek 20mm Servo Horn;