

## Front Suspension:

**RESET**

<b>Ride Height:</b> 23 mm
<b>Camber:</b> N/A
<b>Toe:</b> Tierod Gap = 29.40 mm
<b>Anti-Roll Bar</b>
<b>Size:</b> 2.5 mm (White)
<b>Gap:</b> 2 mm
<b>Ackerman</b>
<b>Notes:</b> #81063 FT Steering Block Arm +2 Deg, Aluminum
<b>Drive Shaft:</b> CVAs: <input checked="" type="checkbox"/> Universals: <input type="checkbox"/>
<b>Chassis Brace:</b> Short: <input checked="" type="checkbox"/> Long: <input type="checkbox"/>
<b>Hex:</b> #81079 +1 mm
<b>Notes:</b> #81085 FT Servo Saver Arm, Aluminum #81026 Front Shock Tower, Aluminum

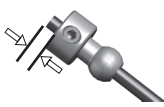

<b>Caster Shim:</b> 1 mm R / 3 mm F
<b>Upper Ball Type:</b> #81067 Steel
<b>Upper Ball Shim:</b> 2.1 mm
<b>Washers:</b> 0
<b>Lower Ball Shim:</b> 0

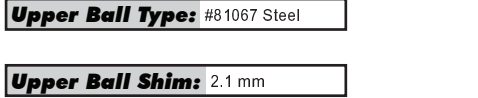
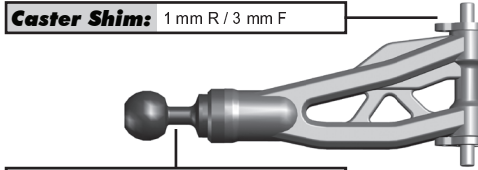

<b>Wheelbase Shim:</b> 1 mm R / 0 mm F
<b>Lower Ball Type:</b> #81067 Steel
<b>Upper Arm Mount:</b>
<b>Arm Mount A:</b>
<b>Arm Mount B:</b>

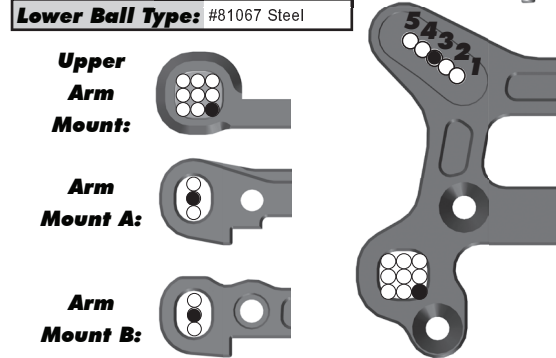
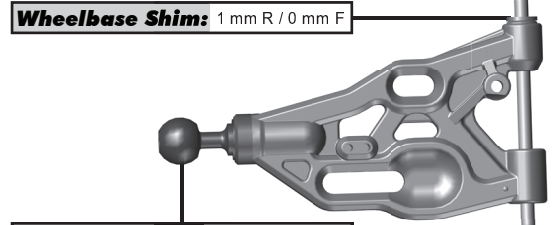

## Rear Suspension:

<b>Ride Height:</b> 29 mm
<b>Camber:</b> Tierod Gap = 16.8 mm
<b>Anti-Roll Bar</b>
<b>Size:</b> 2.8 (Yellow)
<b>Gap:</b> 0, Ball Reversed
<b>Drive Shaft:</b> CVAs: <input checked="" type="checkbox"/> Universals: <input type="checkbox"/>
<b>Chassis Brace:</b> Short: <input checked="" type="checkbox"/> Long: <input type="checkbox"/>
<b>Hex:</b> #81079 +1 mm
<b>Notes:</b> #81027 Rear Shock Tower, Aluminum

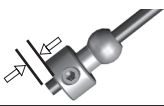

<b>Hub Shim:</b> 2 mm R / 3 mm F
----------------------------------

<b>Wheelbase Shim:</b> 1 mm R / 0 mm F
--

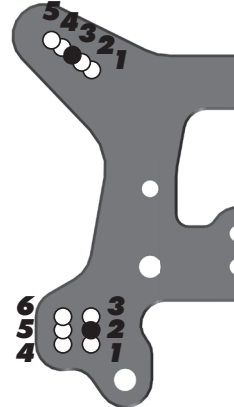
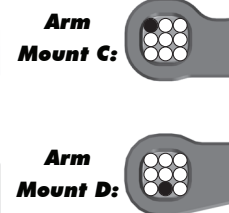
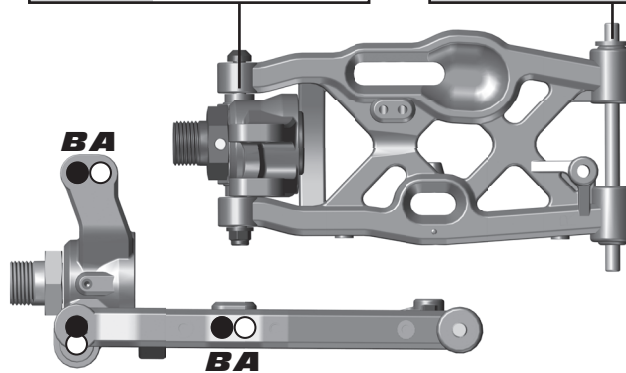

## Electronics and Engine:

<b>Radio:</b> Sanwa
<b>Receiver Battery:</b> LRP 2500 mAh
<b>Throttle Servo:</b> Sanwa PGS-XB
<b>Steering Servo:</b> Sanwa PGS-XB
<b>EPA:</b> Throttle: N/A % Brake: N/A %
<b>Brake Bias:</b> 40%F / 60%R <b>D/R:</b> 100 %
<b>Engine:</b> LRP ZZ 21C Ongaro <b>Temp:</b> N/A
<b>Muffler:</b> OS2090 <b>Fuel:</b> RunnerTime 25%
<b>Restrictor:</b> 5.8 mm <b>Glow Plug:</b> WT3
<b>Notes:</b>

## Differential:

	Fluid	Gear Set	Planet O-Rings
<b>Front:</b>	20,000	HTC	0
<b>Center:</b>	10,000	HTC	0
<b>Rear:</b>	4,000	HTC	0

## Clutch and Gearing:

<b>Spur Gear:</b> 46	<b>Bell:</b> 13
<b>Shoes:</b> 3 x Aluminum	
<b>Springs:</b> 3 x 1.0	
<b>Notes:</b>	

## Shocks:

	Front	Rear
<b>Piston:</b>	#81210 8x1.2, Tapered, Angled	#81211 8x1.3, Tapered, Angled
<b>Fluid:</b>	37.5 wt	35 wt
<b>Cap:</b>	FastRace	FastRace
<b>Rebound:</b>	0	0
<b>Spring:</b>	9.25T / 70 mm	10.75T / 83 mm
<b>Free Length:</b>	105 mm	121 mm
<b>Notes:</b>	#81407 Shock Seal Bushing Set; #81164 & #81165 Fox Shock Bodies; #81174 & #81175 FT Chrome Shock Shafts;	

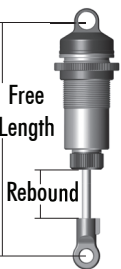

## Track Info:

<b>Size:</b> Small <input type="checkbox"/> Medium <input checked="" type="checkbox"/> Large <input type="checkbox"/> Extra Large <input type="checkbox"/>
<b>Surface:</b> Dirt <input checked="" type="checkbox"/> Carpet <input type="checkbox"/> AstroTurf <input type="checkbox"/> Multi Surface <input type="checkbox"/>
<b>Traction:</b> Low <input type="checkbox"/> Medium <input checked="" type="checkbox"/> High <input type="checkbox"/> Very High <input type="checkbox"/>
<b>Moisture:</b> Dry <input checked="" type="checkbox"/> Damp <input type="checkbox"/> Wet <input type="checkbox"/>
<b>Condition:</b> Indoor <input type="checkbox"/> Outdoor <input checked="" type="checkbox"/> Dusty <input type="checkbox"/> Hard Packed <input type="checkbox"/> Bumpy <input type="checkbox"/> Grooved <input type="checkbox"/> Smooth <input type="checkbox"/> Loamy <input checked="" type="checkbox"/>
<b>Temperature:</b> Ambient: 50 F Track: 50 F
<b>Notes:</b>

## Tires:

<b>Front Tires:</b> AKA Double Down
<b>Front Compound:</b> Super Soft
<b>Front Insert:</b> AKA
<b>Rear Tires:</b> AKA Double Down
<b>Rear Compound:</b> Super Soft
<b>Rear Insert:</b> AKA
<b>Wheel (F/R):</b> AKA
<b>Notes:</b>

## Body, Wings:

<b>Body:</b> JConcepts HB Silencer Lightweight
<b>Wing:</b> Hot Bodies
<b>Wing Height:</b> High: <input type="checkbox"/> Low: <input type="checkbox"/>
<b>Gap to Tower:</b> N/A
<b>Weight:</b>
<b>Total Vehicle Weight:</b> N/A
<b>Notes:</b> #81406 FT Chassis Weight, 30g (Rear); 10g Under Front Center Driveline

## Vehicle Comments:

**Notes:** #81115 Motor Mount; #81382 FT Aluminum Cross Pins; #1367 FT 20mm Servo Horn; RDRP Rear Chassis Brace Mount;