

RESET

Front Suspension:

Ride Height: 24 mm
Camber: 0°
Toe: +2°
Anti-Roll Bar
Size: 2.4 mm (Green)
Gap: 0.5 mm
Ackerman
Notes:
Drive Shaft: CVAs: <input checked="" type="checkbox"/> Universals: <input type="checkbox"/>
Chassis Brace: Short: <input type="checkbox"/> Long: <input checked="" type="checkbox"/>
Hex: #81079 Wheel Hex, +1 mm
Notes:

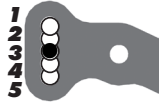
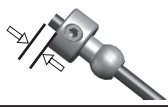

Caster Shim: 2 mm F / 2 mm R
Upper Ball Type: #81067 Steel
Upper Ball Shim: 0.35 mm
Washers: 2 mm
Lower Ball Shim: 0 mm

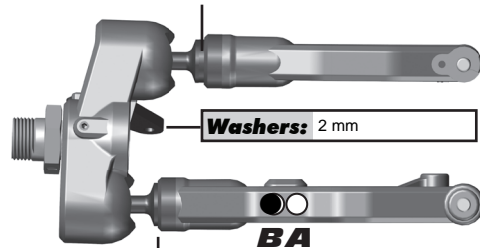
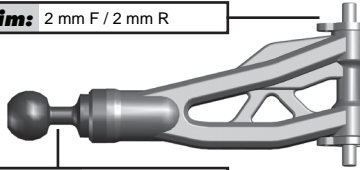

Wheelbase Shim: 1 mm
Lower Ball Type: #81067 Steel
Upper Arm Mount:
Arm Mount A:
Arm Mount B:

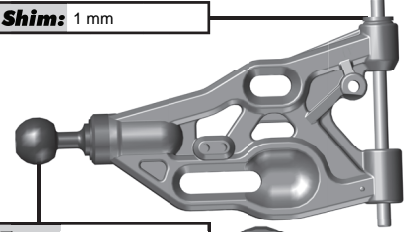

Rear Suspension:

Ride Height: 29 mm
Camber: 0
Anti-Roll Bar
Size: 2.7 mm (Blue)
Gap: 0.5 mm (Ball Reversed)
Drive Shaft: CVAs: <input checked="" type="checkbox"/> Universals: <input type="checkbox"/>
Chassis Brace: Short: <input type="checkbox"/> Long: <input checked="" type="checkbox"/>
Hex: #81079 Wheel Hex, +1 mm
Notes:

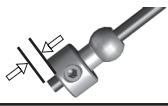

Hub Shim: 1 mm R / 4 mm F
Wheelbase Shim: 1 mm
Arm Mount C:
Arm Mount D:

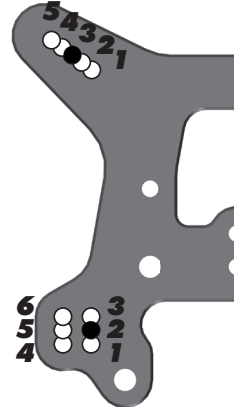
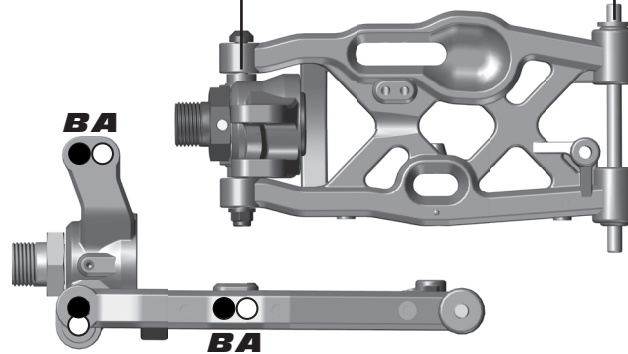

Electronics and Engine:

Radio: Sanwa M12S
Receiver Battery: LRP 2500 mAh
Throttle Servo: Sanwa
Steering Servo: Sanwa
EPA: Throttle: N/A % Brake: N/A %
Brake Bias: N/A D/R: N/A %
Engine: LRP ZZ .21C Temp: N/A
Muffler: LRP Fuel: RunnerTime 25%
Restrictor: NA Glow Plug: LRP WT3
Notes:

Differential:

	Fluid	Gear Set	Planet O-Rings
Front:	10,000	HTC	No
Center:	7,000	HTC	No
Rear:	5,000	HTC	No

Clutch and Gearing:

Spur Gear: 46	Bell: 13
Shoes: 3 x Aluminum	
Springs: 3 x 0.95 mm	
Notes: DKT Clutch	

Shocks:

	Front	Rear
Piston:	8 x 1.2 Kyosho	8 x 1.3 Kyosho
Fluid:	400	400
Cap:	FastRace	FastRace
Rebound:	0	0
Spring:	Mugen 9.25T/70mm	Mugen 10.75T/86 mm
Free Length:	105 mm	119 mm
Notes:		



Track Info:

Size: Small <input type="checkbox"/> Medium <input type="checkbox"/> Large <input type="checkbox"/> Extra Large <input checked="" type="checkbox"/>
Surface: Dirt <input checked="" type="checkbox"/> Carpet <input type="checkbox"/> Astroturf <input type="checkbox"/> Multi Surface <input type="checkbox"/>
Traction: Low <input type="checkbox"/> Medium <input type="checkbox"/> High <input checked="" type="checkbox"/> Very High <input type="checkbox"/>
Moisture: Dry <input checked="" type="checkbox"/> Damp <input type="checkbox"/> Wet <input type="checkbox"/>
Condition: Indoor <input type="checkbox"/> Outdoor <input checked="" type="checkbox"/> Dusty <input checked="" type="checkbox"/> Hard Packed <input checked="" type="checkbox"/> Bumpy <input type="checkbox"/> Grooved <input checked="" type="checkbox"/> Smooth <input type="checkbox"/> Loamy <input type="checkbox"/>
Temperature: Ambient: _____ Track: _____
Notes:

Tires:

Front Tires: AKA Catapult
Front Compound: Super Soft
Front Insert: AKA Red
Rear Tires: AKA Catapult
Rear Compound: Super Soft
Rear Insert: AKA Red
Wheel (F/R): AKA
Notes:

Body, Wings:

Body: JConcepts Silencer
Wing: HB
Wing Height: High: <input checked="" type="checkbox"/> Low: <input type="checkbox"/>
Gap to Tower: AE Kit Location
Weight:
Total Vehicle Weight:
Notes:

Vehicle Comments:

Notes:
