

**:: Front Suspension**

anti-roll bar:  
 2.2 - black  
 2.5 - silver  
 2.8 - gold

kickup bushing  
 # \_\_\_\_\_  
 up  down

steering rack:  
 back  
 mid  
 front

hinge pin bushing  
 # \_\_\_\_\_  
 up  down

camber: \_\_\_\_\_  
 caster: \_\_\_\_\_  
 toe: \_\_\_\_\_  
 ride height: \_\_\_\_\_ mm

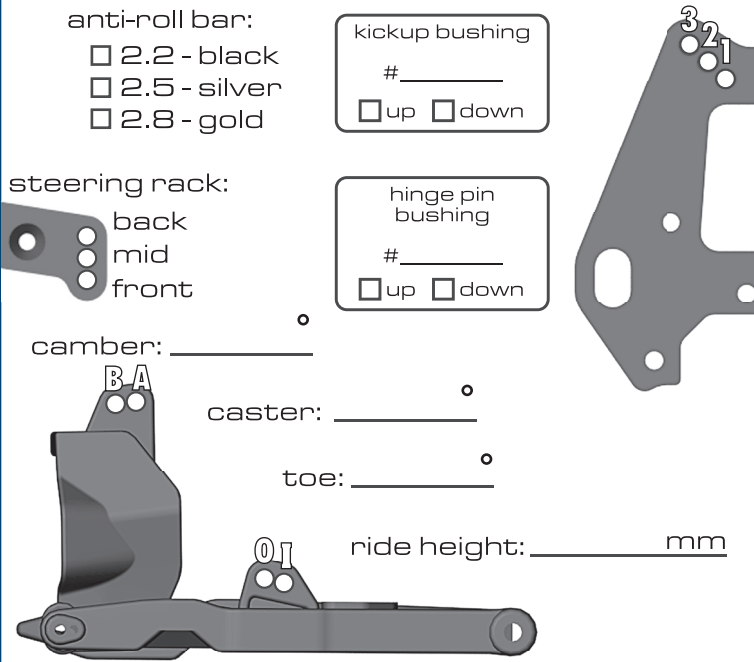

**:: Rear Suspension**

anti-roll bar:  
 2.2 - black  
 2.5 - silver  
 2.8 - gold

anti-squat bushing  
 # \_\_\_\_\_  
 up  down

wheelbase:  
 long  
 medium  
 short

camber: \_\_\_\_\_  
 toe: \_\_\_\_\_  
 ride height: \_\_\_\_\_ mm

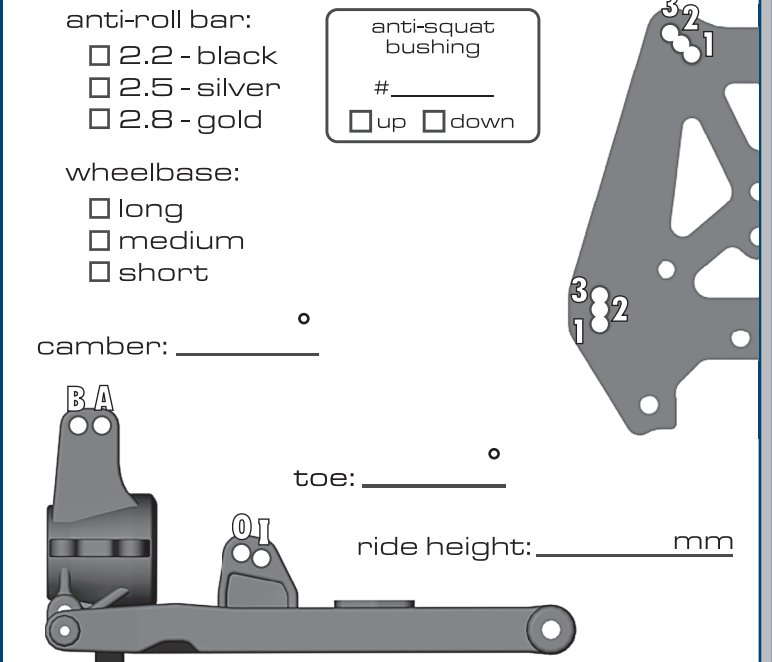

**:: Front Shocks**

spring: \_\_\_\_\_ piston: \_\_\_\_\_  
 shock fluid: \_\_\_\_\_ length: \_\_\_\_\_

**:: Rear Shocks**

spring: \_\_\_\_\_ piston: \_\_\_\_\_  
 shock fluid: \_\_\_\_\_ length: \_\_\_\_\_

**:: Differentials**

front fluid: \_\_\_\_\_  
 center fluid: \_\_\_\_\_  
 rear fluid: \_\_\_\_\_

**:: Wing**

location:  forward  back  
 angle:  low  med.  high  
 type: \_\_\_\_\_

**:: Notes**

\_\_\_\_\_  
 \_\_\_\_\_  
 \_\_\_\_\_

**:: Engine**

engine: \_\_\_\_\_ restrictor: \_\_\_\_\_  
 muffler: \_\_\_\_\_ temp: \_\_\_\_\_  
 glow plug: \_\_\_\_\_  
 fuel: \_\_\_\_\_

**:: Gearing/Clutch**

gearing: \_\_\_\_\_  
 clutch shoes: \_\_\_\_\_  
 clutch spring: \_\_\_\_ .9mm \_\_\_\_ 1.0mm \_\_\_\_ 1.1 mm  
 other: \_\_\_\_\_

**:: Front Tires**

tire: \_\_\_\_\_  
 compound: \_\_\_\_\_  
 insert: \_\_\_\_\_  
 wheel: \_\_\_\_\_

**:: Rear Tires**

tire: \_\_\_\_\_  
 compound: \_\_\_\_\_  
 insert: \_\_\_\_\_  
 wheel: \_\_\_\_\_

**:: Race and Vehicle Comments**

qualify: \_\_\_\_\_ main: \_\_\_\_\_ finish: \_\_\_\_\_ tq:   
 comments: \_\_\_\_\_  
 \_\_\_\_\_  
 \_\_\_\_\_  
 \_\_\_\_\_

**:: Track Info**

smooth:  bumpy:  blue groove:   
 traction- high:  med:  low:   
 soft dirt:  grass:  clay:  wet:   
 dusty:  other: \_\_\_\_\_  
 \_\_\_\_\_  
 \_\_\_\_\_