

Front Suspension

Anti Roll Bar:

- 2.2mm Green
- 2.3mm White
- 2.4mm Blue
- 2.5mm Yellow

Steering System:

- Swing Rack
 - Bellcrank Rack
- back mid front

Bumpsteer

Washers: _____ 1 mm

Camber: _____ -1*

Caster: _____ 16*

Toe: _____ -1*

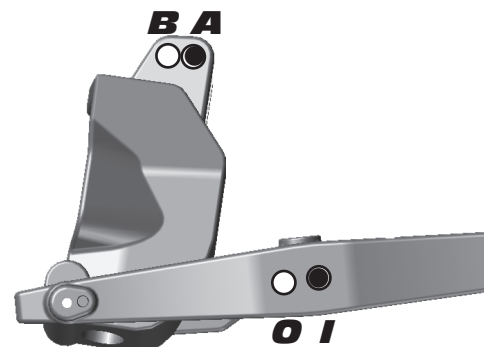

Ride Height: _____ 29 mm

Upper Hinge Pin Bushing

Front # _____ 1

Up Down

Rear # _____ 2

Up Down

B-Plate Type

Low Original

Kickup Bushing A-Plate

_____ 1

Up Down

Rear Suspension

RESET

Anti Roll Bar:

- 2.5mm Green
- 2.6mm White
- 2.7mm Blue
- 2.8mm Yellow

Wheelbase:

- Long
- Medium
- Short

Camber: _____ -2*

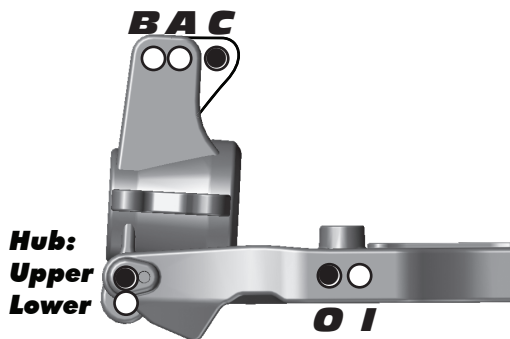

Hub:

Upper

Lower

Ride Height: _____ 29 mm

Toe Bushing D-Plate

_____ GHEA LRC 1 Dot

In Out

Squat Bushing C-Plate

_____ GHEA LRC 2 Dot

Up Down

Front Shocks

Spring: _____ Silver **Shock Cap:** _____ Associated

Shock Fluid: _____ Associated 42.5 Wt **Length:** _____ 97.5 mm

Piston: _____ 8 x 1.3 Tapped **Rebound:** _____ 5 mm

Rear Shocks

Spring: _____ Silver **Shock Cap:** _____ Associated

Shock Fluid: _____ Associated 30 wt **Length:** _____ 119 mm

Piston: _____ 8 x 1.3 Tapered **Rebound:** _____ 5 mm

Chassis Braces

- Chassis Braces:**
- Pivot
- Molded
- Aluminum

Wheel Hex

- Wheel Hex:**
- Narrow
- Wide

Caster Blocks

- Caster Blocks:**
- Vertical
- Inclined

Chassis Weight

Weight: _____ 3430g

Rear Hubs

- Rear Hubs:**
- Standard
- CNC FT Alum.

Differentials

Front Diff: _____ 5,000

Center Diff: _____ 3,000

Rear Diff: _____ 5,000

Notes: _____ 80% Full

Body / Wing

Body Type: _____ JConcepts Finisher

Wing Type: _____ UpGrade Vortex (High Wing Mount)

Gap to Tower (MM): _____ 36 mm

Gearing

Spur Gear: _____ 46

Pinion: _____ 18

Motor / ESC / Batteries

Motor & Wind: _____ Reedy Sonic 2100kV

ESC: _____ LRP iX8

ESC Setting: _____

Batteries: _____ Reedy #311 4S

Tires

Tire (F/R): _____ JConcepts Black Jackets / JConcepts Black Jackets

Compound (F/R): _____ Black / Black

Inserts (F/R): _____ JConcepts Dirt Tech / JConcepts Dirt Tech

Wheel (F/R): _____ JConcepts Bullet / JConcepts Bullet

Notes: _____

Radio / Servos

Radio: _____ Airtronics M12

Steering Servo: _____ Savox SC-1258TG **Steering Expo:** _____ 0%

Brake Expo: _____ 0% **Brake EPA:** _____ 78%

Dual Rate: _____ 95%

Notes: _____

Race and Vehicle Comments

Qualify: _____ 15 **Main:** _____ A **Finish:** _____ **TQ:** _____

Comments: _____ No shock boots; Reedy #307 LiFe Receiver Battery

Track Info

- Traction:** High Medium Low
- Surface:** Smooth Bumpy Blue Groove
- Soft Dirt Grass Clay Wet
- Astroturf Dusty Other: _____