

Front Suspension

Anti Roll Bar:

2.2mm Green
 2.3mm White
 2.4mm Blue
 2.5mm Yellow

Steering System:

Bellcrank
 Steering Rack:



Bumpsteer

Washers: _____ 0

Camber: _____ -1

Caster: _____ 16

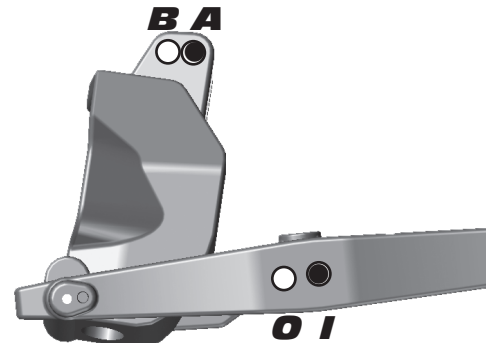
Toe: _____ 0



Ride Height: _____ 28 mm

Upper Hinge Pin Bushing

Front # _____ 2

Up Down

Rear # _____ 2

Up Down

B-Plate Type

Low Original

Kickup Bushing A-Plate

_____ 2

Up Down

Rear Suspension

RESET
Anti Roll Bar:

2.5mm Green
 2.6mm White
 2.7mm Blue
 2.8mm Yellow

Wheelbase:

Long
 Medium
 Short

Camber: _____ -1

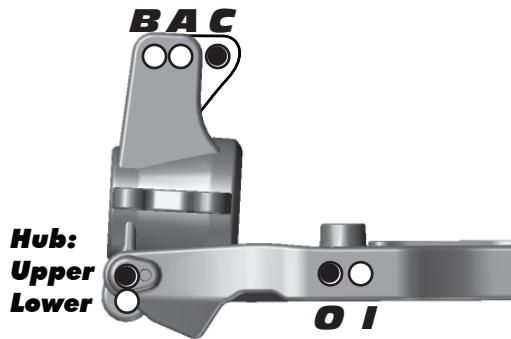

Ride Height: _____ 28 mm

Toe Bushing D-Plate

_____ GHEA LRC 3 Down

In Out

Squat Bushing C-Plate

_____ GHEA LRC 2 Down

Up Down

Front Shocks

Spring: _____ Kyo Lt Blue
Shock Fluid: _____ 45 wt
Piston: _____ 8 x 1.3mm
Shock Cap: _____ Bladder
Length: _____ 99 mm
Rebound: _____ 0

Rear Shocks

Spring: _____ Kyo Lt Blue
Shock Fluid: _____ 35 wt
Piston: _____ 8 x 1.3mm
Shock Cap: _____ Bladder
Length: _____ 118.5 mm
Rebound: _____ 0

Chassis Braces / Wheel Hex

Chassis Braces:
 Pivot
 Molded
 Aluminum

Wheel Hex:
 Standard
 Narrow

Chassis Weight

Weight: _____

Rear Hubs

Rear Hubs:
 Standard
 CNC FT Alum.

Differentials

Front Diff Fluid: _____ 5000
Center Diff Fluid: _____ 7000
Rear Diff Fluid: _____ 5000
Notes: _____

Body / Wing

Body Type: _____ JConcepts Punisher
Wing Type: _____ UpGrade Vortex
Gap to Tower (MM): _____ 30 mm

Gearing

Spur Gear: _____ 46
Pinion: _____ 17

Motor / ESC / Batteries

Motor & Wind: _____ Reedy Sonic 2100 kV
ESC: _____ LRP iX8
ESC Setting: _____ 0/1/2/2
Batteries: _____ Reedy 4S WolfPack 3700

Tires

Tire (F/R): _____ JConcepts Barcodes / JConcepts Barcode
Compound (F/R): _____ Yellow / Yellow
Inserts (F/R): _____ Pro-Line Closed Cell / Pro-Line Closed Cell
Wheel (F/R): _____ Associated 83 mm / Associated 83 mm
Notes: _____ Capital "Y" to the outside on both front and rear tires

Radio / Servos

Radio: _____ Airtronics M11x
Steering Servo: _____ HiTech
Steering Expo: _____ 0%
Brake Expo: _____ **Brake EPA:** _____
Initial Brake: _____ **Drag Brake:** _____
Dual Rate: _____ 100%

Race and Vehicle Comments

Qualify: _____ 2 **Main:** _____ A **Finish:** _____ 1 **TQ:** _____
Comments: _____ Vertical caster blocks; External receiver pack; High wing mount; 79% Brake EPA

Track Info

Traction: _____ High Medium Low
Surface: _____ Smooth Bumpy Blue Groove
Soft Dirt **Grass** **Clay** **Wet**
Astroturf **Dusty** **Other:** _____ Tight