

Front Suspension

Anti Roll Bar:

- 2.2mm Green
- 2.3mm White
- 2.4mm Blue
- 2.5mm Yellow

Steering System:

- Swing Rack
- Bellcrank Rack

Bumpsteer
Washers: _____ 0

Camber: _____ -2°

Caster: _____ 16

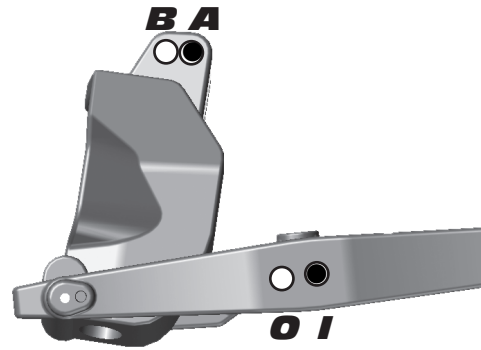
Toe: _____ 0°

Ride Height: _____ 27mm

Upper Hinge Pin Bushing
Front # _____ 1
Up **Down**
Rear # _____ 2
Up **Down**

B-Plate Type
Low **Original**

Kickup Bushing A-Plate
_____ 2
Up **Down**

Rear Suspension

RESET
Anti Roll Bar:

- 2.5mm Green
- 2.6mm White
- 2.7mm Blue
- 2.8mm Yellow

Wheelbase:

- Long
- Medium
- Short

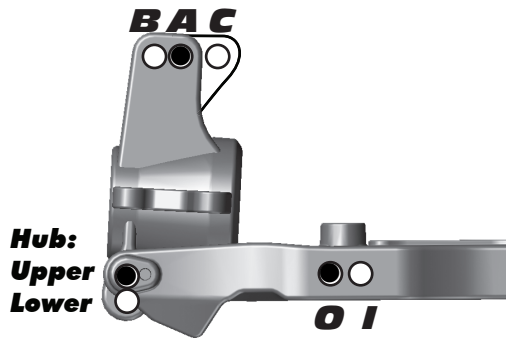
Camber: _____ -2°

Ride Height: _____ 28mm

Toe Bushing D-Plate
_____ 1
In **Out**

Squat Bushing C-Plate
_____ 1
Up **Down**

Front Shocks

Spring: _____ Ky light blue **Shock Cap:** _____ Bladder
Shock Fluid: _____ 45 **Length:** _____ 101
Piston: _____ 8x1.3 **Rebound:** _____ 0

Rear Shocks

Spring: _____ Ky light blue **Shock Cap:** _____ Bladder
Shock Fluid: _____ 35 **Length:** _____ 122
Piston: _____ 8x1.3 **Rebound:** _____ 0

Chassis Braces

- Chassis Braces: _____
- Pivot
- Molded
- Aluminum

Wheel Hex

- Wheel Hex: _____
- Narrow
- Wide

Caster Blocks

- Caster Blocks: _____
- Vertical
- Inclined

Chassis Weight

Weight: _____

Rear Hubs

- Rear Hubs: _____
- Standard
- CNC FT Alum.

Differentials

Front Diff: _____ 5000
Center Diff: _____ 10'000
Rear Diff: _____ 3000
Notes: _____

Body / Wing

Body Type: _____ Proline Bulldog
Wing Type: _____ Proline
Gap to Tower (MM): _____

Gearing

Spur Gear: _____ 46
Pinion: _____ 18

Motor / ESC / Batteries

Motor & Wind: _____ Hacker Skalar 1900KV
ESC: _____ Hacker Tensoric 8
ESC Setting: _____
Batteries: _____ Hacker Top Fuel 6500

Tires

Tire (F/R): _____ /
Compound (F/R): _____ /
Inserts (F/R): _____ /
Wheel (F/R): _____ /
Notes: _____

Radio / Servos

Radio: _____ Sanwa M11x
Steering Servo: _____ XP1015 **Steering Expo:** _____ 0
Brake Expo: _____ **Brake EPA:** _____
Dual Rate: _____ 100%
Notes: _____

Race and Vehicle Comments

Qualify: _____ 7 **Main:** _____ 5 **Finish:** _____ 3 **TQ:** _____
Comments: _____

Track Info

Traction: **High** **Medium** **Low**
Surface: **Smooth** **Bumpy** **Blue Groove**
Soft Dirt **Grass** **Clay** **Wet**
Astroturf **Dusty** **Other:** _____