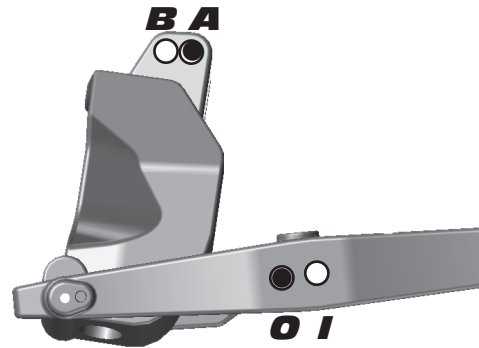
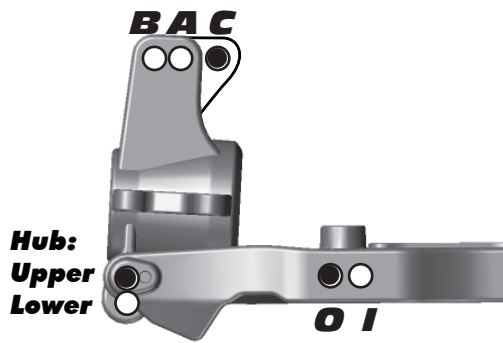

**Front Suspension**
**Steering System:**
**Swing Rack**  **Anti Roll Bar:**  
**Bellcrank Rack** 
**2.2mm Green**   
**2.3mm White**   
**2.4mm Blue**   
**2.5mm Yellow** 
**Bumpsteer**
**Washers:** \_\_\_\_\_ None \_\_\_\_\_

**Camber:** \_\_\_\_\_ -1 \_\_\_\_\_

**Caster:** \_\_\_\_\_ 16 \_\_\_\_\_

**Toe:** \_\_\_\_\_ -1/2 \_\_\_\_\_

**Upper Hinge Pin Bushing**  
**Front #** \_\_\_\_\_ 3 \_\_\_\_\_  
**Up**  **Down**   
**Rear #** \_\_\_\_\_ 2 \_\_\_\_\_  
**Up**  **Down** 
**B-Plate Type**  
**Low**  **Original** 
**Kickup Bushing A-Plate**  
**#** \_\_\_\_\_ 2 \_\_\_\_\_  
**Up**  **Down** 
**Ride Height:** \_\_\_\_\_ 28 mm \_\_\_\_\_

**Rear Suspension**
**RESET**
**Wheelbase:**
**Long**   
**Medium**   
**Short** 
**Anti Roll Bar:**
**2.5mm Green**   
**2.6mm White**   
**2.7mm Blue**   
**2.8mm Yellow** 
**Camber:** \_\_\_\_\_ -1 \_\_\_\_\_

**Toe Bushing D-Plate**  
**#** \_\_\_\_\_ 1 \_\_\_\_\_  
**In**  **Out** 
**Squat Bushing C-Plate**  
**#** \_\_\_\_\_ 2 \_\_\_\_\_  
**Up**  **Down** 
**Hub:**  
**Upper** \_\_\_\_\_  
**Lower** \_\_\_\_\_

**Ride Height:** \_\_\_\_\_ 28 mm \_\_\_\_\_

**Front Shocks**
**Spring:** \_\_\_\_\_ Ky Lt Blue \_\_\_\_\_ **Shock Cap:** \_\_\_\_\_ Bladder \_\_\_\_\_  
**Shock Fluid:** \_\_\_\_\_ 30 wt Associated \_\_\_\_\_ **Length:** \_\_\_\_\_ 100 mm \_\_\_\_\_  
**Piston:** \_\_\_\_\_ 8 x 1.3 Tapered+ \_\_\_\_\_ **Rebound:** \_\_\_\_\_ 0 \_\_\_\_\_

**Rear Shocks**
**Spring:** \_\_\_\_\_ Ky Lt Blue \_\_\_\_\_ **Shock Cap:** \_\_\_\_\_ Bladder \_\_\_\_\_  
**Shock Fluid:** \_\_\_\_\_ 27.5 wt Associated \_\_\_\_\_ **Length:** \_\_\_\_\_ 118 mm \_\_\_\_\_  
**Piston:** \_\_\_\_\_ 8 x 1.3 Tapered+ \_\_\_\_\_ **Rebound:** \_\_\_\_\_ 0 \_\_\_\_\_

**Chassis Braces / Wheel Hex**
**Chassis Braces:** **Wheel Hex:**  
**Pivot**  **Standard**   
**Molded**  **Narrow**   
**Aluminum** 
**Chassis Weight**
**Weight:** \_\_\_\_\_  
 \_\_\_\_\_  
 \_\_\_\_\_

**Rear Hubs**
**Rear Hubs:**  
**Standard**   
**CNC FT Alum.** 
**Differentials**
**Front Diff Fluid:** \_\_\_\_\_ 5000 \_\_\_\_\_  
**Center Diff Fluid:** \_\_\_\_\_ 3000 \_\_\_\_\_  
**Rear Diff Fluid:** \_\_\_\_\_ 3000 \_\_\_\_\_

**Body / Wing**
**Body Type:** \_\_\_\_\_ Pro-Line Bull Dog \_\_\_\_\_  
**Wing Type:** \_\_\_\_\_ UpGrade Vortex \_\_\_\_\_  
 \_\_\_\_\_ RC8.2 low wing mount \_\_\_\_\_  
**Gap to Tower (MM):** \_\_\_\_\_ 36 mm \_\_\_\_\_

**Gearing / Clutch**
**Spur Gear:** \_\_\_\_\_ 44 \_\_\_\_\_  
**Clutch Bell:** \_\_\_\_\_ 17 \_\_\_\_\_  
**Clutch Shoes:** \_\_\_\_\_ LRP Aluminum \_\_\_\_\_  
**Clutch Spring:** \_\_\_\_\_ 3 x 1.0 mm \_\_\_\_\_

**Engine**
**Engine:** \_\_\_\_\_ LRP \_\_\_\_\_  
**Restrictor:** \_\_\_\_\_ 6 mm \_\_\_\_\_ **Temp:** \_\_\_\_\_ 105C \_\_\_\_\_  
**Muffler:** \_\_\_\_\_ Novarossi 9901 / Reedy Header \_\_\_\_\_  
**Glow Plug:** \_\_\_\_\_ WT3 \_\_\_\_\_ **Fuel:** \_\_\_\_\_ LRP 25% \_\_\_\_\_

**Tires**
**Tire (F/R):** \_\_\_\_\_ Pro-Line Hoeshot 2.0 / \_\_\_\_\_ Pro-Line Hoeshot 2.0 \_\_\_\_\_  
**Compound (F/R):** \_\_\_\_\_ M4 / \_\_\_\_\_ M4 \_\_\_\_\_  
**Inserts (F/R):** \_\_\_\_\_ Pro-Line Closed Cell / \_\_\_\_\_ Pro-Line Closed Cell \_\_\_\_\_  
**Wheel (F/R):** \_\_\_\_\_ Associated 83 mm / \_\_\_\_\_ Associated 83 mm \_\_\_\_\_  
**Notes:** \_\_\_\_\_

**Radio / Servos**
**Radio:** \_\_\_\_\_ KO \_\_\_\_\_ **Brake Bias:** \_\_\_\_\_ 50/50 \_\_\_\_\_  
**Throttle / Steering Servo:** \_\_\_\_\_ KO / \_\_\_\_\_ KO \_\_\_\_\_  
**Throttle / Brake expo:** \_\_\_\_\_ 0% / \_\_\_\_\_ 0% \_\_\_\_\_  
**Steering expo:** \_\_\_\_\_ 0% \_\_\_\_\_  
**Dual Rate:** \_\_\_\_\_ 100% \_\_\_\_\_

**Race and Vehicle Comments**
**Qualify:** \_\_\_\_\_ **Main:** \_\_\_\_\_ **Finish:** \_\_\_\_\_ **TQ:** \_\_\_\_\_  
**Comments:** LRP clutch; Ride height set with full fuel tank; No shock boots; Throttle opens 60%;  
 Steering speed 80%; Reedy LiFe receiver pack; Aluminum front chassis brace; Plastic rear chassis  
 brace; Steering rack ballstud in the middle  
 \_\_\_\_\_  
 \_\_\_\_\_

**Track Info**
**Traction:** **High**  **Medium**  **Low**   
**Surface:** **Smooth**  **Bumpy**  **Blue Groove**   
**Soft Dirt**  **Grass**  **Clay**  **Wet**   
**Astroturf**  **Dusty**  **Other:** \_\_\_\_\_ Indoors \_\_\_\_\_