

12R5.2

::Driver: Keven Hebert

::Date: October 2012

::Track: IIC 2012

::Event: Mod 1/12

Setup sheet for Team Associated's 12R5.2

::Front Suspension

Ride height: 3.2

Upper arm mounts: 0° 5° 10°



Camber: °1.25 Toe: °0.5 out

Droop: 0.5mm

Bumpsteer shims: tall ball stud

King pin lube: 15000 Kyosho

Springs: .021

Front Brace: None Soft Hard

Front width: .5mm on bottom arm and 2 kingpin shim on front axle

Roll Center

Shims on top of the steering block: 0

Shims between bulkhead and caster block: 2mm

Notes:

long upper link

::Front Tires

Brand & compound: Parma Pink

Diameter: 40

Wheel: Parma

Tire treatment: JTG

Treatment time: 10min

Surface treated: half

Notes:

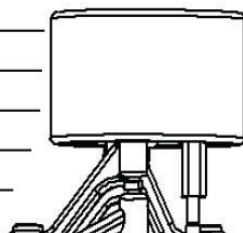

::Rear Suspension

Ride height adjuster: 3.25

Chassis ride height: 3.2

Pod ride height: 3.2

Droop: 1.2mm

Rear width: 171.5

Shims under pivot: 0

Side damper

Springs: black

Oil: 20000 CST

Notes:

Center damper

Brand: AE

Spring: Blue

Oil: 27.5

Position:

High Low

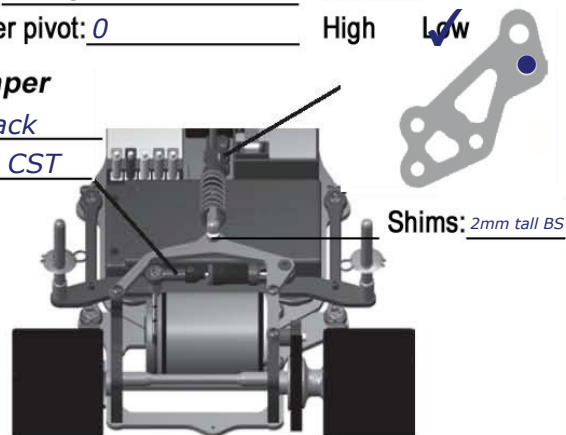

::Body

Brand & model: Protoform AMR 12

Notes:

Light

::Track Info

Composition: Asphalt Carpet

Surface: Smooth Bumpy

Traction: High Medium Low

Notes:

::Motor / Battery

Motor: 3.5 Rotor: _____

Timing: 27.5

Pinion: 24 Spur: 96

Rollout: 32.594

Battery: Reedy 6800

Plugs position: Front Back

::Speed Control

ESC: Flow

Setting: _____

::Transmitter

Turning Circle: 4ft

Steering Expo: -15%

Brake E.P.: _____

Throttle Expo: _____

Notes: