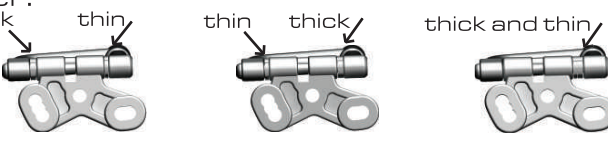

:: Driver: Juho Levanen **:: Date:** _____
:: Track: High Traction Carpet
:: Event: EFRA Indoor Championship

Setup Sheet for Team Associated's 12R5

Reset Forms **Rev. 1**

:: Front Suspension

Kingpin Lube: AE Silicone Grease #6636
 Springs: 0.020
 Upper Arm Mounts: 0° 5° 10°
 Camber: -1.5 Axle Spacers: 1.5 mm
 Bump Steer Spacers: None
 Caster:
 thick thin thin thick thick and thin

 1.80° 3.25° 6.15°
 Ride Height: 1 mm shim / 3.25 mm
 Notes: Front width 166 mm

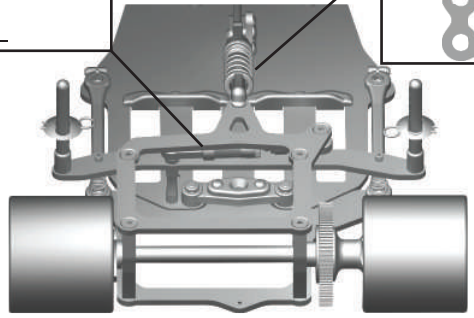
:: Rear Suspension

Side Spring: Gold
 T-Plate: N/A
 Ride Height Adjuster: -3.25
 Ride Height: -3.25
 Side Shock
 Oil: 30 wt
 Center Shock
 Oil: 30 wt
 Spring: Gold
 Position: 

 Notes: 1 mm droop; 171 mm wide; Wide rear pod with narrow rear hub

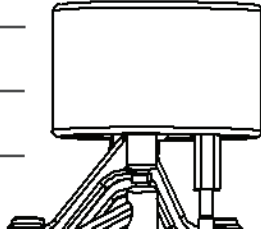
:: Front Tires

Tire: Jaco Double Pink
 Diameter: 41 mm
 Wheel Type: Jaco
 Additive: Jack The Gripper 1/3rd inside
 Notes: Let additive sit for 10 minutes



:: Rear Tires

Tire: Jaco Yellow
 Diameter: 43 mm
 Wheel Type: Jaco
 Additive: Jack The Gripper Full
 Notes: Let additive sit for 10 minutes

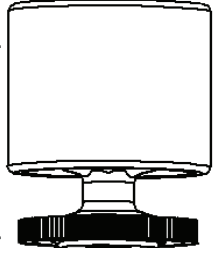

:: Body

Body Type and Make: Parma Zytac

Notes: Lightweight

:: Track Info

smooth: bumpy:
 traction: high med. low
 Notes: _____

:: Motor/Battery

Motor: LRP X12 5.0 Turn
 Brush: N/A Spring: N/A
 Timing: 1 Dot Gear: 96 / 23
 Battery: Reedy IB 4800
 Battery Position:
 Front Back

:: Speed Control

S.C. : LRP Sphere Comp
 S.C. Settings: 2/4/0/0

:: Transmitter

Turning Circle: 1.2 m (4 feet)
 Steering Expo: 60%
 Brake E.P. : 60%
 Throttle Expo: 0%
 Notes: _____