

**:: Driver:** \_\_\_\_\_ **:: Date:** \_\_\_\_\_  
**:: Track:** \_\_\_\_\_  
**:: Event:** \_\_\_\_\_

## Setup Sheet for Team Associated's 12R5

Rev. 1

### :: Front Suspension

Kingpin Lube: \_\_\_\_\_  
 Springs: \_\_\_\_\_  
 Upper Arm Mounts:  0°  5°  10°

Camber: \_\_\_\_\_

Caster:

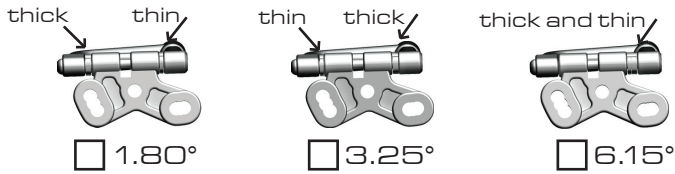

Ride Height: \_\_\_\_\_

Notes: \_\_\_\_\_

### :: Rear Suspension

Side Spring: \_\_\_\_\_  
 T-Plate: \_\_\_\_\_  
 Ride Height Adjuster: \_\_\_\_\_  
 Ride Height: \_\_\_\_\_

Center Shock  
 Oil: \_\_\_\_\_  
 Spring: \_\_\_\_\_  
 Position: \_\_\_\_\_

Side Shock  
 Oil: \_\_\_\_\_

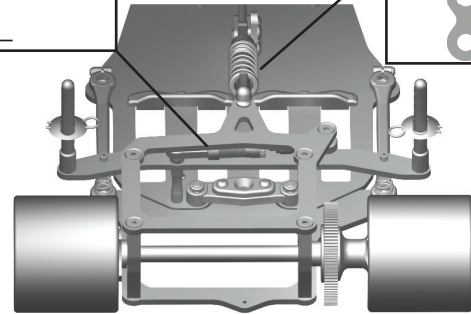

Notes: \_\_\_\_\_

### :: Front Tires

Tire: \_\_\_\_\_  
 Diameter: \_\_\_\_\_  
 Wheel Type: \_\_\_\_\_  
 Additive: \_\_\_\_\_  
 Notes: \_\_\_\_\_

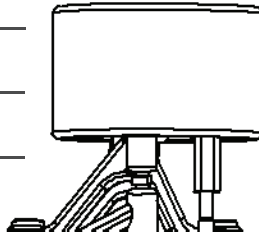

### :: Rear Tires

Tire: \_\_\_\_\_  
 Diameter: \_\_\_\_\_  
 Wheel Type: \_\_\_\_\_  
 Additive: \_\_\_\_\_  
 Notes: \_\_\_\_\_

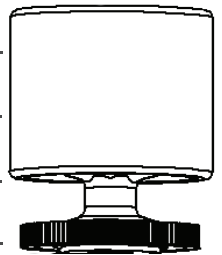

### :: Body

Body Type and Make: \_\_\_\_\_

Notes: \_\_\_\_\_

### :: Track Info

smooth:  bumpy:   
 traction:  high  med.  low  
 Notes: \_\_\_\_\_

### :: Motor/Battery

Motor: \_\_\_\_\_  
 Brush: \_\_\_\_\_ Spring: \_\_\_\_\_  
 Timing: \_\_\_\_\_ Gear: \_\_\_\_\_ / \_\_\_\_\_  
 Battery: \_\_\_\_\_  
 Battery Position:  
 Front  Back

### :: Transmitter

Turning Circle: \_\_\_\_\_  
 Steering Expo: \_\_\_\_\_  
 Brake E.P. : \_\_\_\_\_  
 Throttle Expo: \_\_\_\_\_  
 Notes: \_\_\_\_\_

### :: Speed Control

S.C. : \_\_\_\_\_  
 S.C. Settings: \_\_\_\_\_