

**:: Driver:** Mike Blackstock **:: Date:** \_\_\_\_\_  
**:: Track:** IIC LAS VEGAS  
**:: Event:** IIC 2008 LAS VEGAS

## Setup Sheet for Team Associated's 12R5

**Reset Fields** **Rev. 1**

### :: Front Suspension

Kingpin Lube: 60k  
 Springs: .020  
 Upper Arm Mounts:  0°  5°  10°  
 Camber: -.05  
 Caster:



Ride Height: 3.8mm  
 Notes: \_\_\_\_\_

front end spaced out .060 per side

### :: Rear Suspension

Side Spring: silver  
 T-Plate: \_\_\_\_\_  
 Ride Height Adjuster: \_\_\_\_\_  
 Ride Height: 4.0mm  
 Side Shock  
 Oil: 20  
 Center Shock  
 Oil: 20  
 Spring: copper  
 Position: 

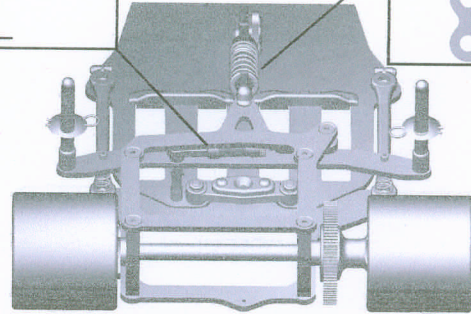

Notes: Standard droop spacer in center shock  
 rear axle shimmed to max width

### :: Front Tires

Tire: Jaco Dbl Pink  
 Diameter: 1.68 inches  
 Wheel Type: \_\_\_\_\_  
 Additive: jack the gripper, 1/3 of the tire  
 Notes: Apply additive 20 mins before race

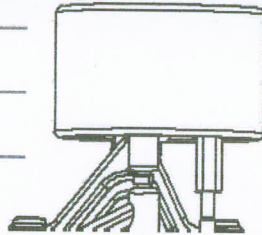

### :: Rear Tires

Tire: Jaco pink  
 Diameter: 1.72 inches  
 Wheel Type: \_\_\_\_\_  
 Additive: jack the gripper, full tire  
 Notes: Apply additive 20 mins before race

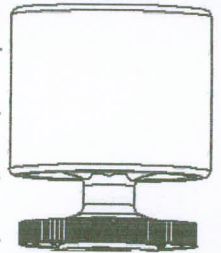

### :: Body

Body Type and Make: Protoform Speed 12  
 Notes: \_\_\_\_\_

### :: Track Info

smooth:  bumpy:   
 traction:  high  med.  low  
 Notes: \_\_\_\_\_

### :: Motor/Battery

Motor: checkpoint 4.5  
 Brush: \_\_\_\_\_ Spring: \_\_\_\_\_  
 Timing: \_\_\_\_\_ Gear: \_\_\_\_\_/  
 Battery: SMC ENERGY 4600  
 Battery Position:  
 Front  Back

### :: Transmitter

Turning Circle: 70%  
 Steering Expo: 0  
 Brake E.P.: 60%  
 Throttle Expo: 0  
 Notes: \_\_\_\_\_

### :: Speed Control

S.C.: \_\_\_\_\_  
 S.C. Settings: \_\_\_\_\_

**:: For more setups, visit [www.RC10.com](http://www.RC10.com)**