

# 12R5.1

**:: Driver:** Rick Hohwart **:: Date:** 9/13/09  
**:: Track:** Riviera Hotel  
**:: Event:** 2009 International Indoor Championships (IIC)

## Setup Sheet for Team Associated's 12R5.1

**Reset Forms** **Rev. 1**

### :: Front Suspension

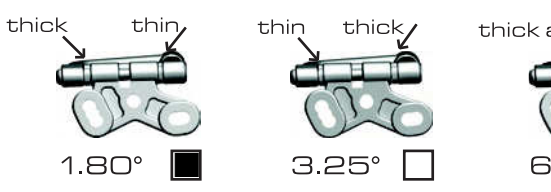
Kingpin Lube: 30K  
Springs: .020  
Upper Arm Mounts: 0°  5°  10°   
Camber: 1 deg  
Caster:  
  
1.80°  3.25°  6.15°   
Ride Height: 3.5mm  
Notes: \_\_\_\_\_

### :: Rear Suspension

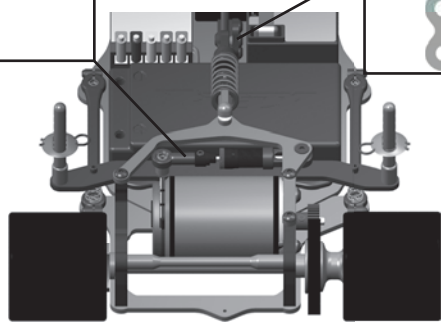
Side Spring: gold  
T-Plate: -  
Ride Height Adjuster: 1  
Ride Height: 3.5mm  
Center Shock  
Oil: 30  
Spring: gold  
Position:   
Side Shock  
Oil: 30  
  
Notes: \_\_\_\_\_

### :: Front Tires

Tire: Parma Magenta  
Diameter: 41mm  
Wheel Type: Parma  
Additive: Jack 50%  
Notes: \_\_\_\_\_

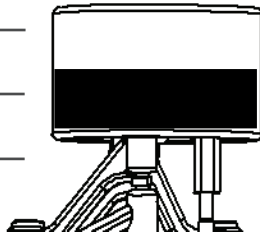

### :: Rear Tires

Tire: Parma Magenta  
Diameter: 43mm  
Wheel Type: Parma  
Additive: Jack 100%  
Notes: \_\_\_\_\_

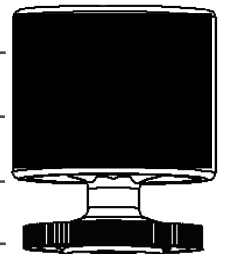

### :: Body

Body Type and Make: Protoform AMR-12

Notes: \_\_\_\_\_

### :: Track Info

smooth:  bumpy:   
traction: high  med.  low   
Notes: \_\_\_\_\_

### :: Motor/Battery

Motor: LRP X12  
Brush: - Spring: -  
Timing: Stock Gear: 25 / 96  
Battery: Reedy 4600mAh 1S 3.7V  
Battery Position:  
Front  Back

### :: Speed Control

S.C. : LRP SXX Competition  
S.C. Settings: 2-4-2-2

### :: Transmitter

Turning Circle: 80%  
Steering Expo: -10%  
Brake E.P. : 65%  
Throttle Expo: 0%  
Notes: \_\_\_\_\_