

12R5.2

::Driver: olly jefferies

::Date: 20/02/12

::Track: teesside

::Event: brca rd5

Setup sheet for Team Associated's 12R5.2

::Front Suspension

Ride height: 3.5

Upper arm mounts: 0° 5° 10°



Camber: °1

Toe: °0

Droop: 0

Bumpsteer shims: 1mm black ballstud

King pin lube: black grease

Springs: 0.18 with pre load

Front Brace: None Soft Hard

Front width: stock

Roll Center

Shims on top of the steering block: stock

Shims between bulkhead and caster block: 2mm

Notes:

::Front Tires

Brand & compound: jaco magenta

Diameter: 41.5

Wheel: jaco

Tire treatment: cs

Treatment time: 20 min

Surface treated: 1/2

Notes:

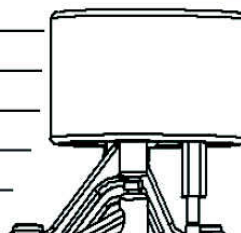

::Rear Suspension

Ride height adjuster: 2.5

Chassis ride height: 3.5

Pod ride height: 3.5

Droop: 1.2

Rear width: 170

Shims under pivot: -0.6

Center damper

Brand: ae

Spring: blue

Oil: 25

Position:

High Low

Side damper

Springs: green

Oil: 25



Shims: 2mm

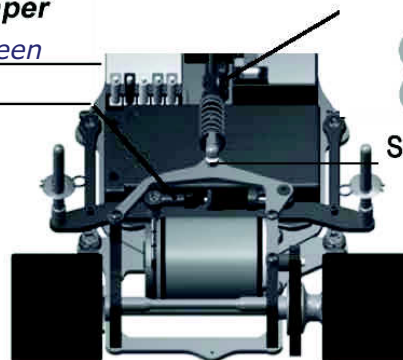

Notes:

pivot balls lowered by 0.6mm

::Rear Tires

Brand & compound: jaco magenta

Diameter: 43mm

Wheel: jaco

Tire treatment: cs

Treatment time: 20min

Surface treated: full

Notes:

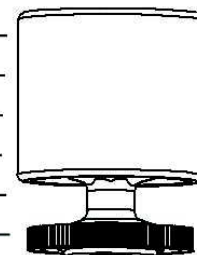

::Body

Brand & model: protofrom amr light

Notes:

::Track Info

Composition: Asphalt Carpet

Surface: Smooth Bumpy

Traction: High Medium Low

Notes:

::Motor / Battery

Motor: reedy sonic 4.0 Rotor: std

Timing: 2marks

Pinion: 25 Spur: 96

Rollout: 0.000

Battery: reedy

Plugs position: Front Back

::Speed Control

ESC: lrp sxx v2 1.7 firmware

Setting: 0864

::Transmitter

Turning Circle: 1.2 feet

Steering Expo: -15

Brake E.P.: 0

Throttle Expo: 0

Notes: