

12R5.2

::Driver: _____ ::Date: _____
::Track: _____
::Event: _____

Setup sheet for Team Associated's 12R5.2

::Front Suspension

Ride height: _____
Upper arm mounts: 0° 5° 10°
 Thick Thin Thin Thick Thick & Thin

 1.80° 3.25° 6.15°
Camber: _____ Toe: _____
Droop: _____
Bumpsteer shims: _____
King pin lube: _____
Springs: _____
Front Brace: None Soft Hard _____
Front width: _____

Roll Center

Shims on top of the steering block: _____
Shims between bulkhead and caster block: _____
Notes: _____

::Front Tires

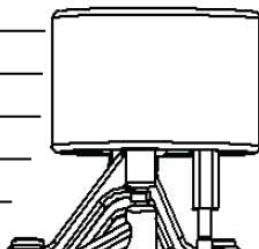
Brand & compound: _____
Diameter: _____
Wheel: _____
Tire treatment: _____
Treatment time: _____
Surface treated: _____
Notes: _____



::Body

Brand & model: _____
Notes: _____

::Track Info

Composition: Asphalt Carpet
Surface: Smooth Bumpy
Traction: High Medium Low
Notes: _____

::Rear Suspension

Ride height adjuster: _____ *Center damper*
Chassis ride height: _____ Brand: _____
Pod ride height: _____ Spring: _____
Droop: _____ Oil: _____
Rear width: _____ Position: _____
Shims under pivot: _____ High Low

Side damper

Springs: _____
Oil: _____
Shims: _____

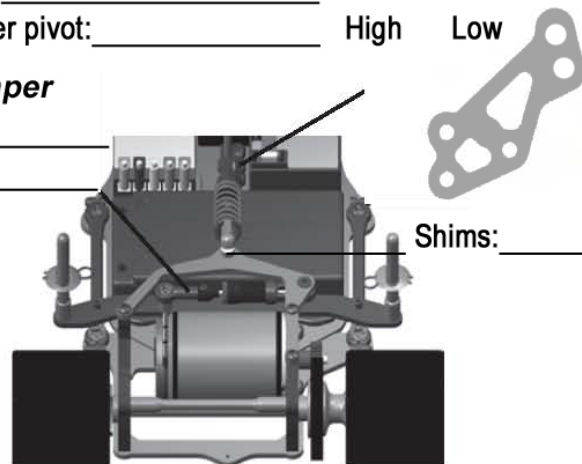

Notes: _____

::Rear Tires

Brand & compound: _____
Diameter: _____
Wheel: _____
Tire treatment: _____
Treatment time: _____
Surface treated: _____
Notes: _____

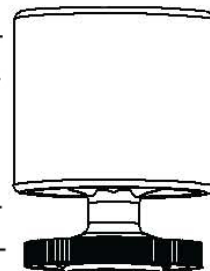

::Motor / Battery

Motor: _____ Rotor: _____
Timing: _____
Pinion: _____ Spur: _____
Rollout: _____
Battery: _____
Plugs position: Front Back

::Speed Control

ESC: _____
Setting: _____

::Transmitter

Turning Circle: _____
Steering Expo: _____
Brake E.P.: _____
Throttle Expo: _____
Notes: _____