

12R5.1

:: Driver: Olly Jefferies **:: Date:** 12/17/18
:: Track: Ardent raceway
:: Event: EPS RD2

Setup Sheet for Team Associated's 12R5.1

Reset Forms **Rev. 1**

:: Front Suspension

Kingpin Lube: none
Springs: #18
Upper Arm Mounts: 0° 5° 10°

Camber: 1.5

Caster:

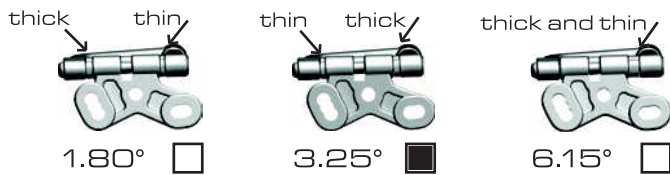

Ride Height: 3.5

Notes: top link shimmed 3mm inwards, no front cross brace

:: Rear Suspension

Side Spring: green

T-Plate: ----

Ride Height Adjuster: 2.5

Ride Height: 3.5

Side Shock

Oil: 25

Center Shock

Oil: 25

Spring: blue

Position:

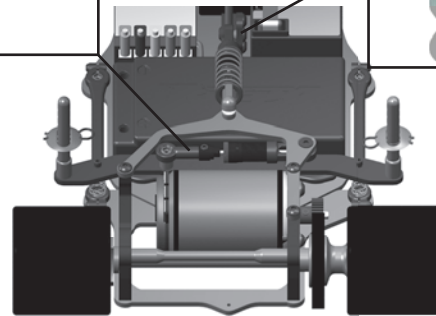

Notes: Lipo inline conversion use, lipo placed in car with terminals towards the front.

:: Front Tires

Tire: jaco magenta

Diameter: 41.5

Wheel Type: jaco

Additive: cs

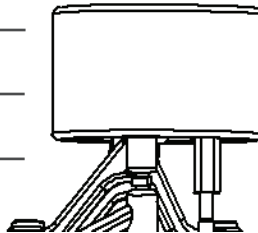

Notes: just less than half front additive
front and rear additive applied at same time for 20 minutes

clean whole tyre first with additive

:: Rear Tires

Tire: jaco magenta

Diameter: 43

Wheel Type: jaco

Additive: cs

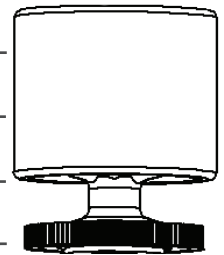

Notes: full. front and rear additive applied at same time for 20 minutes
clean whole tyre first with additive.

:: Body

Body Type and Make: protoform amr lightweight

Notes:

:: Motor/Battery

Motor: reedy 3.5

Brush: --- Spring: ---

Timing: 3 mark Gear: 25 / 96

Battery: reedy #600

Battery Position:

Front Back

:: Speed Control

S.C. : lrp sxx v2

S.C. Settings: 0/8/6/3

:: Transmitter

Turning Circle: 1.5 feet

Steering Expo: -15

Brake E.P. : 0

Throttle Expo: 0

Notes:

:: Track Info

smooth: bumpy:

traction: high med. low

Notes:

:: For more setups, visit www.RC10.com and click on "Racing" then "Setups"