

12R5.1

:: Driver: Olly Jefferies **:: Date:** 10/23/11
:: Track: Ardent Raceway
:: Event: BRCA National rd1

Setup Sheet for Team Associated's 12R5.1

Reset Forms **Rev. 1**

:: Front Suspension

Kingpin Lube: AE BLACK GREASE

Springs: 20

Upper Arm Mounts: 0° 5° 10°

Camber: 1

Caster:

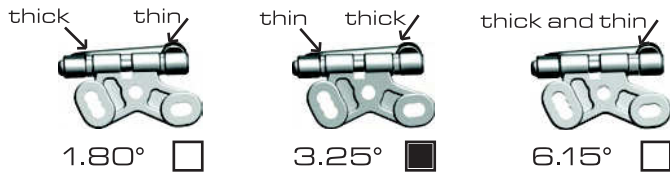

Ride Height: 3.5

Notes: FRONT BRACE REMOVED

:: Rear Suspension

Side Spring: GOLD

T-Plate: N/A

Ride Height Adjuster: 2.25

Ride Height: 3.5

Side Shock

Oil: 25

Center Shock

Oil: 25

Spring: GOLD

Position:

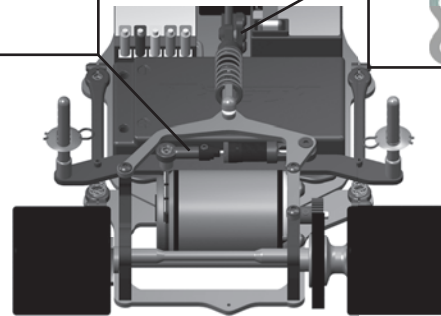

Notes: LOWER HOLE ON CENTRE SHOCK MOUNT FOR NEW CAR LIPO PLACED IN CAR WITH CONNECTORS TOWARDS FRONT

:: Front Tires

Tire: JACO MAGENTA

Diameter: 42.5

Wheel Type: JACO

Additive: SPEEDTECH

Notes: 75% ADDITIVE, 20 MINUTES

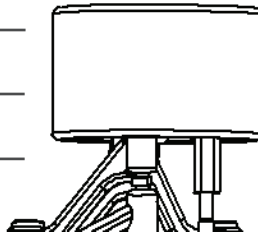

:: Rear Tires

Tire: JACO MAGENTA

Diameter: 43.5

Wheel Type: JACO

Additive: SPEEDTECH

Notes: 100% ADDITIVE, 20 MINUTES.

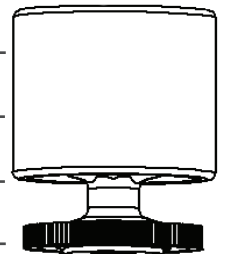

:: Body

Body Type and Make: PROTOFORM AMR

Notes: LIGHTWEIGHT

:: Track Info

smooth: bumpy:

traction: high med. low

Notes:

:: Motor/Battery

Motor: LRP 4.5

Brush: N/A Spring: N/A

Timing: 0000 Gear: 26 / 96

Battery: REEDY 6500

Battery Position:

Front Back

:: Speed Control

S.C. : LRP SXX V2

S.C. Settings: 0442

:: Transmitter

Turning Circle: 2F

Steering Expo: -15

Brake E.P. : 0

Throttle Expo: 0

Notes:

:: For more setups, visit www.RC10.com and click on "Racing" then "Setups"