

# 12R5.1

**:: Driver:** Mike Blackstock **:: Date:** 11/30/11  
**:: Track:** Holiday Inn Rockside  
**:: Event:** US indoor Champs

## Setup Sheet for Team Associated's 12R5.1

Reset Forms **Rev. 1**

### :: Front Suspension

Kingpin Lube: 10k

Springs: .018

Upper Arm Mounts: 0°  5°  10°

Camber: -2 deg

Caster:

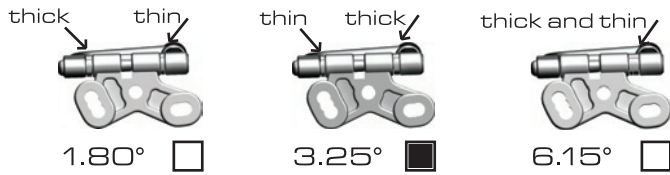

Ride Height: 3.2

Notes: car has very little front droop..

### :: Rear Suspension

Side Spring: Black

T-Plate:

Ride Height Adjuster: 2.5

Ride Height: 3.2

Side Shock

Oil: 30

Center Shock

Oil: 40

Spring: Blue

Position:

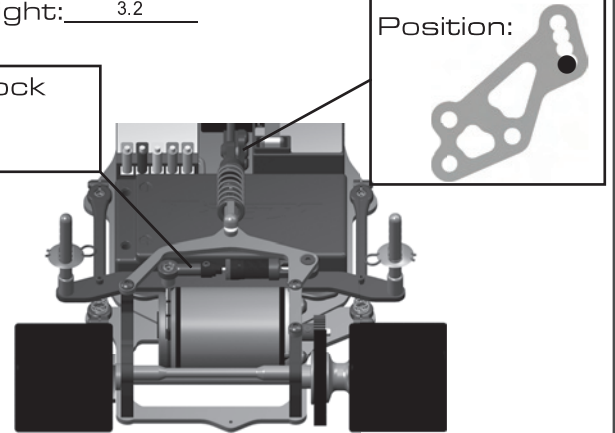

Notes: Lipo Conversion kit. Battery mount so plugs are in the front of the car.

Car has 1.5 mm of up travel from a flat pod.

### :: Front Tires

Tire: jaco magenta

Diameter: 1.56

Wheel Type: Jaco

Additive: SXT

Notes: sauced 3/4 front tire

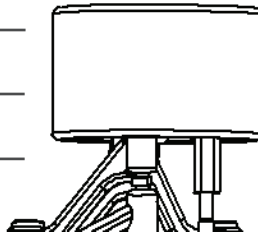

### :: Rear Tires

Tire: Jaco Magenta

Diameter: 1.66

Wheel Type: Jaco

Additive: SXT

Notes: Full sauce on the rear

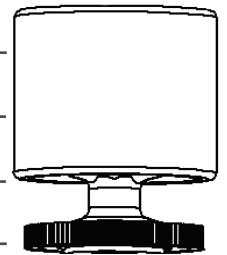

### :: Body

Body Type and Make: amr 12

Notes: body mounted 5mm forward !

### :: Track Info

smooth:  bumpy:

traction: high  med.  low

Notes: Qualified 1st Finished 10th

Car was very fast. Had fastest laps all weekend . Made a mistake

In the A main to finish 10th.

### :: Motor/Battery

Motor: RevTech 3.5

Brush: Spring:

Timing: Gear: 26 / 96

Battery: SMC 60C 6100

Battery Position:

Front  Back

### :: Speed Control

S.C. : LRP Stock Spec

S.C. Settings: 0214

### :: Transmitter

Turning Circle:

Steering Expo:

Brake E.P. :

Throttle Expo:

Notes:

**:: For more setups, visit [www.RC10.com](http://www.RC10.com) and click on "Racing" then "Setups"**