

12R5.1

:: Driver: Mike Blackstock **:: Date:** 10/30/11
:: Track: The Gate...
:: Event: Halloween Classic

Setup Sheet for Team Associated's 12R5.1

Reset Forms **Rev. 1**

:: Front Suspension

Kingpin Lube: 30k

Springs: .018

Upper Arm Mounts: 0° 5° 10°

Camber: -2 deg

Caster:

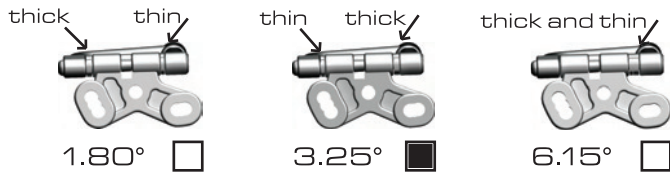

Ride Height: 3.2

Notes: car has very little front droop..

:: Rear Suspension

Side Spring: Black

T-Plate:

Ride Height Adjuster: 2.5

Ride Height: 3.4

Side Shock

Oil: 20

Center Shock

Oil: 30

Spring: gold

Position:

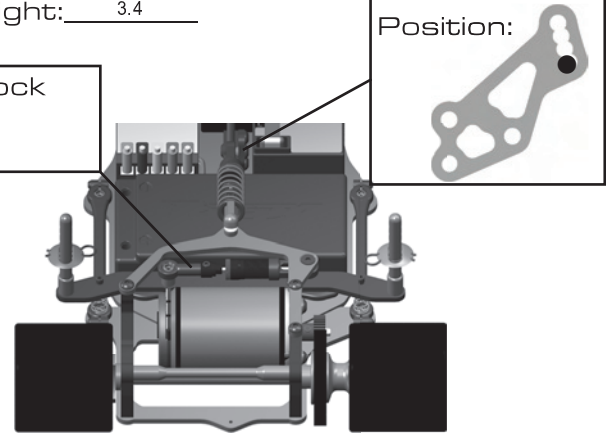

Notes: Lipo Conversion kit. Battery mount so plugs are in the front of the car.

Car has 1.5 mm of up travel from a flat pod.

:: Front Tires

Tire: jaco magenta

Diameter: 1.56

Wheel Type: jaco

Additive: SXT

Notes: sauced 3/4 front tire

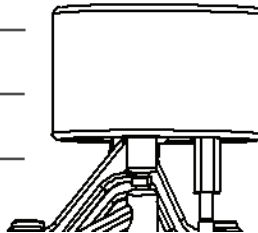

:: Rear Tires

Tire: Jaco Magenta

Diameter: 1.66

Wheel Type: jaco

Additive: SXT

Notes: Full sauce on the rear

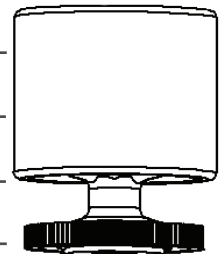

:: Body

Body Type and Make: amr 12

Notes: body mounted 5mm forward !

:: Track Info

smooth: bumpy:

traction: high med. low

Notes: Qualified 1st Finished 1st

:: Motor/Battery

Motor: RevTech 3.5

Brush: Spring:

Timing: Gear: 26 / 96

Battery: SMC 60C 6100

Battery Position:

Front Back

:: Speed Control

S.C. : LRP Stock Spec

S.C. Settings: 0214

:: Transmitter

Turning Circle:

Steering Expo:

Brake E.P. :

Throttle Expo:

Notes:

:: For more setups, visit www.RC10.com and click on "Racing" then "Setups"