

T84 TEAM KIT

1:10 Scale 4WD Electric Off Road
Competition Truck Kit

RC10

SINCE 1984



TEAM ASSOCIATED



1:10 Scale 4WD Electric Off Road Competition Truck Kit Manual

#90057 RC10T84 Team Kit



CHAMPIONS by DESIGN

AssociatedElectrics.com

TEAM ASSOCIATED

⚡ Introduction

Thank you for purchasing this Team Associated product. This assembly manual contains instructions and tips for building and maintaining your new vehicle. Please take a moment to read through the manual and familiarize yourself with the steps. We are continually changing and improving our designs; therefore, actual parts may appear slightly different than the illustrations. New parts will be noted on supplementary sheets located in the appropriate parts bags. Check each bag for these sheets before you start to build. Check www.rc10.com for the latest versions of our instruction manuals.

⚡ RC10T84 Features

- New Truck Specific Gull Wing Long Arm Suspension
- New Truck Specific Body
- 25mm and 31mm Length 13mm Big-bore Shock Bodies
- TiN gold 3x24mm and 3x29mm Shock Shafts
- Molded Shock Tower Covers Front and Rear
- New Wide Tongue Chassis for Improved Durability
- New Wide A and B Mounts
- New Molded Front Bumper With Optional Bumper That Covers Anti-roll Bar Mounts
- Longer Front CVA Axle For Truck Specific Wheels
- Metal Ring and Pinion Gears with Molded Internal Gears Included
- Center Differential Included

LEGACY FEATURES FROM THE B84

- Molded Height-Adjustable Gearboxes Front and Rear with Additional +2 Rear Gearbox for High-Grip Conditions
- Optimized Steering Bellcranks and Rack: improved bumpsteer control at all ride heights
- Chassis Bracing: Fine tune chassis flex characteristics with upper and lower chassis bracing front and rear
- Standard and HRC (High Roll Center) Rear Hubs Included
- Insert adjustable caster block with 0, +/-1, and +/-2 degree inserts included
- Forward and Back Motor Positions: used for further weight bias adjustment
- Highly Adjustable Battery Holder with Thumb Tabs: allows for easy battery removal and fine tuning of weight bias
- 2.5mm Thick Tapered 7075-T6 Aluminum Chassis with 10 Degrees of Kickup and Improved Departure Angle
- Aluminum Center-Mounted Servo Mount
- Two heights Included for Rear Wing Mount
- 7-inch Rear Wing
- 3.5mm Turnbuckles and Ballcaps

⚡ Additional

Your new RC10T84 Kit comes unassembled and requires the following items for completion (refer to AssociatedElectrics.com for suggestions):

- R/C two channel surface frequency radio system
- AA-size batteries for transmitter
- Electronic Speed Control ("ESC")
- Steering servo
- R/C electric motor
- Pinion gear, size determined by type/turn or kV of motor

- Battery charger (a peak detection charger, or LiPo compatible charger)
- 2 cell LiPo battery pack
- Polycarbonate specific spray paint
- Cyanoacrylate glue ("CA") (#1697)
- Thread locking compound (#1596)
- Tires and Inserts, Fronts and Rears

⚡ Other Helpful Items

- Silicone Shock Fluid (Refer to AssociatedElectrics.com for complete listings)
- FT Body Scissors (#1737)
- FT Hex/Nut Wrenches (#1519)
- FT Universal Tire Balancer (#1498)
- FT Dual Turnbuckle Wrench (#1114)
- FT Body Reamer (#1499)
- Needle Nose Pliers
- Calipers or a Precision Ruler
- Green Slime shock lube (#1105)
- Shock Pliers (#1681)
- FT Ballcup Wrench (#1579)
- Soldering Iron
- Wire Cutters
- Hobby Knife



















Associated Electrics, Inc.
21062 Bake Parkway.
Lake Forest, CA 92630













Customer Service
Tel: 949.544.7500
Fax: 949.544.7501

Hardware - 1:1 Scale View





Button Head (bhcs)

	2x4mm (31510)
	2.5x5mm (31519)
	2.5x6mm (31520)
	2.5x8mm (31521)
	2.5x10mm (31522)
	3x4mm (91158)
	3x5mm (31530)
	3x6mm (31531)
	3x8mm (31532)
	3x10mm (25211)
	3x12mm (89202)
	3x14mm (25187)
	3x16mm (89203)
	3x18mm (2308)
	3x20mm (25188)
	3x22mm (25189)
	3x24mm (89204)
	3x30mm (91478)







Flat Head (fhcs)

	2x3mm (91743)
	2.5x8mm (31472)
	3x5mm (31540)
	3x6mm (31541)
	3x8mm (25201)
	3x10mm (25202)
	3x12mm (25203)
	3x14mm (89208)
	3x16mm (25204)
	3x18mm (89209)





LP Socket Head (lp shcs)

	3x6mm (41089)
	3x8mm (41096)
	3x10mm (41090)
	3x22mm (41095)
	3x24mm (41097)







Set Screws

	3x2.5mm (31500)
	3x3mm (25225)
	3x6mm (81257)
	3x10mm (4671)
	3x20mm (91737)
	4x5mm (25226)













Nuts (lock/plain)

	M3 Nut (91477)
	M3 Alum. Locknut, Blue (31550)
	M3 Locknut, Black (25215)
	M3 Locknut w/Flange (25612)
	FT 3mm Locknuts, Blue (25392)
	M4 Locknuts: Serrated Steel LP (91150)
	Serrated Steel (Silver) (91826)
	FT Aluminum (Blue) (31551)
	Serrated Aluminum (Black) (91738)





Ball Bearings

	4x7x2.5mm (31732)
	5x8x2.5mm (31400)
	5x10x4mm (91560)
	5x10x4mm flanged (92324)
	5x12x4 (91567)
	10x15x4 (91563)
	12x18x4 (92544)

Ballstuds

	HD, short neck 4mm (32041)
	Ti HD, short neck 4mm (32095)
	HD, short neck 6mm (32042)
	Ti HD, short neck 6mm (32096)
	HD, short neck 8mm (32040)
	Ti HD, short neck 8mm (32097)
	HD 6mm (91047)
	Ti HD 6mm (91751)
	HD 8mm (91048)
	Ti HD 8mm (91752)
	HD 10mm (91049)
	Ti HD 10mm (91753)

Shims and Washers

	5.5x0.5mm (31381)
	5.5x1.0mm (31382)
	5.5x2.0mm (31383)
	3x8mm Washer (89218)

Notes:

Table of Contents

1.....	Cover	15.....	Turnbuckles Build Bag 8
2.....	Introduction	16.....	Center Differential Build Bag 9
3.....	1:1 Hardware “Fold Out”	17.....	Anti-Roll Bars Build Bag 10
4.....	Table of Contents	17.....	Shocks Build Bag 11
5.....	Chassis and Steering Build Bag 1	20.....	Electronics, Wheels, Body Build Bag 12
7.....	Suspension Arms Build Bag 2	22.....	Tuning Tips
8.....	Front / Rear Gear Differentials Build Bag 3	24.....	Setup Sheet “Kit Setup”
8.....	Front / Rear Gearbox Build Bag 4	25.....	Setup Sheet “Blank”
11.....	Shock Tower Build Bag 5	26.....	Back Cover
13.....	Caster and Steering Block Build Bag 6		
14.....	Rear Hubs Build Bag 7		

Notes



This symbol indicates a special note or instruction in the manual.



This symbol indicates the number of the same part that is required.



This symbol indicates the order within a step to assemble parts.



This symbol indicates there are optional FT parts available



This symbol indicates a Racers Tip.



This symbol indicates where Thread Lock Adhesive should be applied. *not included

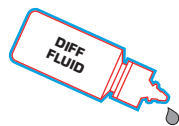

This symbol indicates where Diff Fluid should be applied.

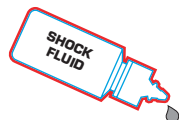

This symbol indicates where Shock Fluid should be applied.



This symbol indicates where FT Silicone Grease should be applied. *not included



This symbol indicates where FT Diff Lube should be applied. *not included



This symbol indicates where Black Grease should be applied.



This symbol indicates where Green Slime can be applied. *not included



There is a 1:1 hardware foldout page in the front of the manual. To check the size of a part, line up your hardware with the correct drawing until you find the exact size. Each part in the foldout has a number assigned to it for ordering replacement parts.

:: Bag 1 - Step 1

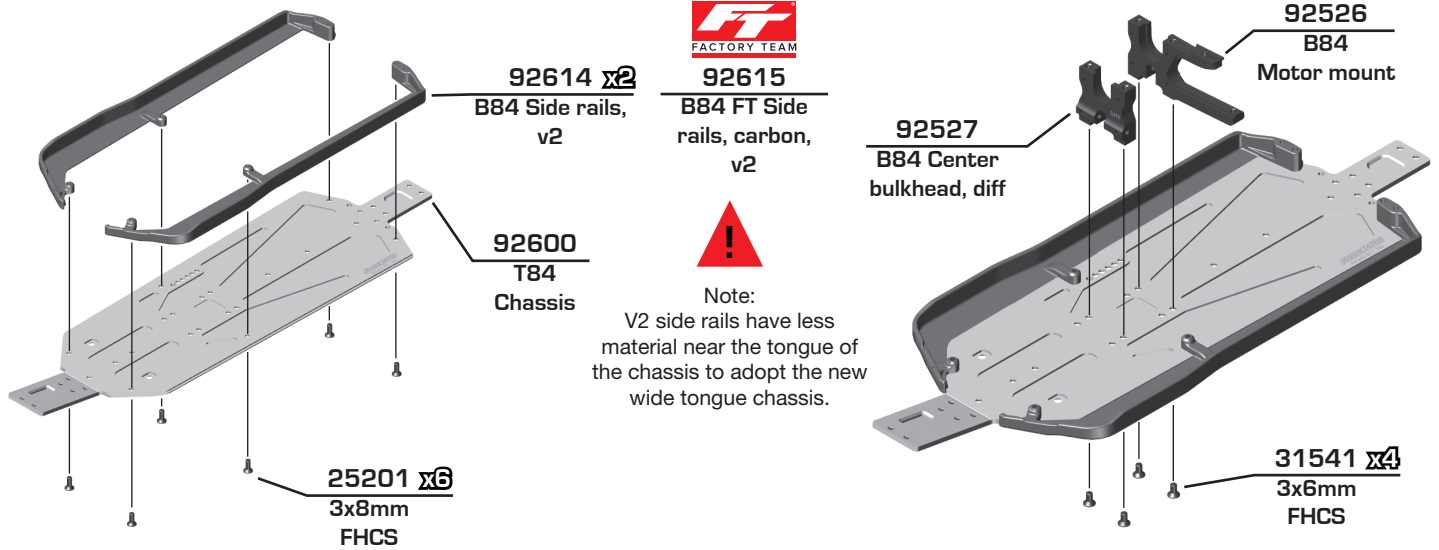

:: Bag 1 - Step 2

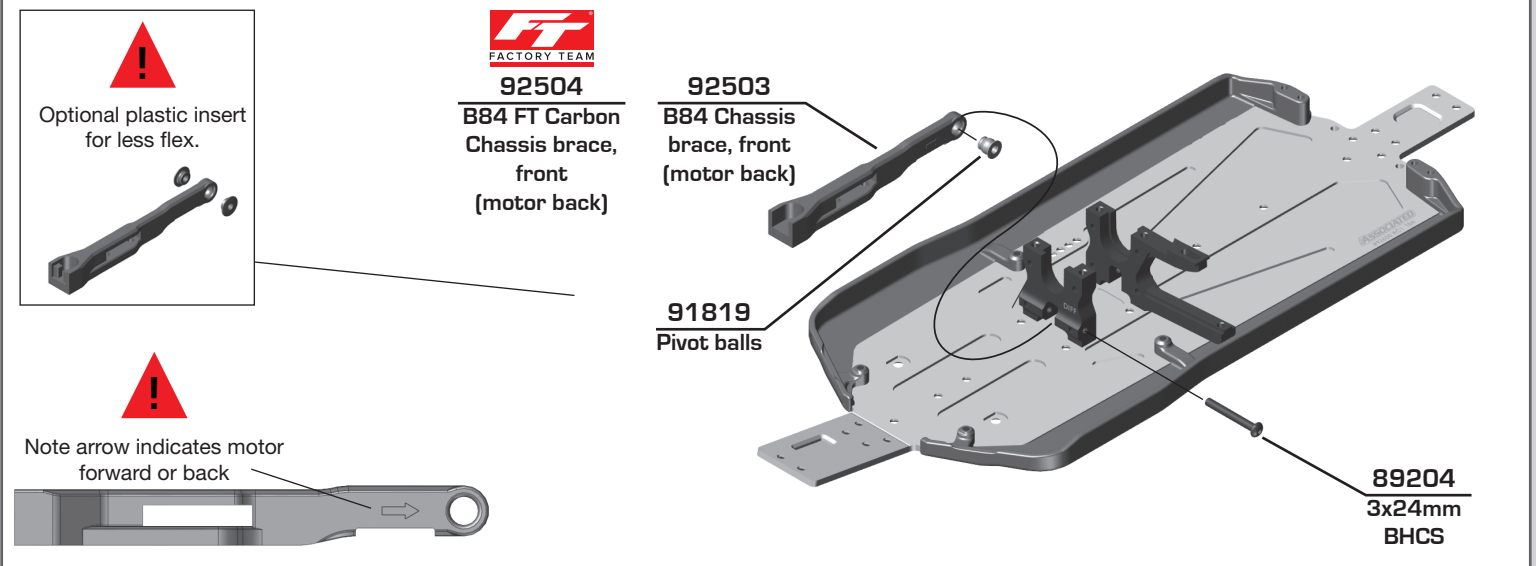

:: Bag 1 - Step 3

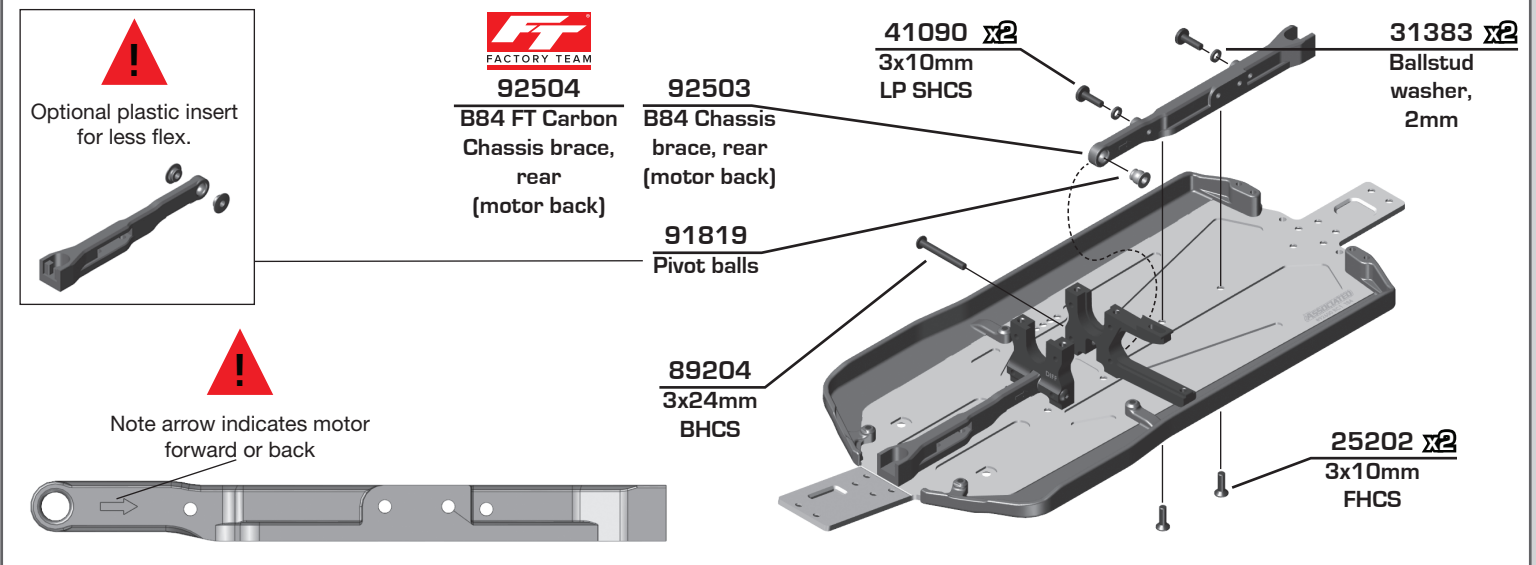

Bag 1 - Step 4

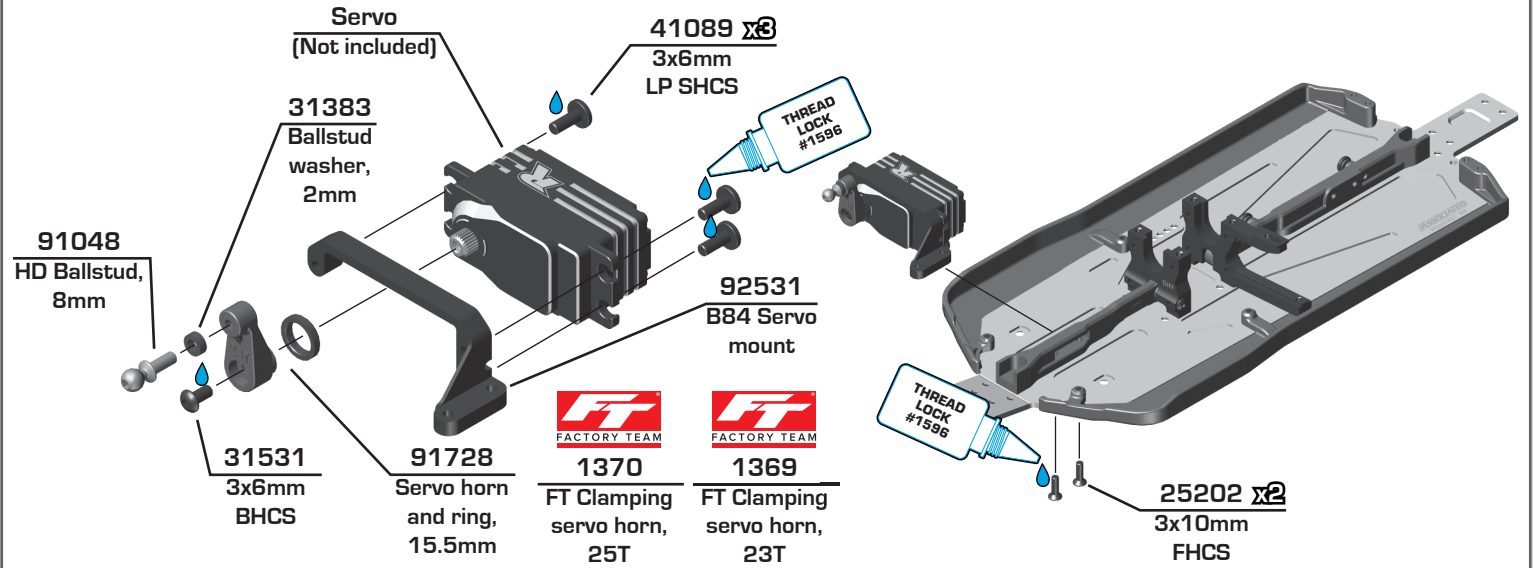

Bag 1 - Step 5

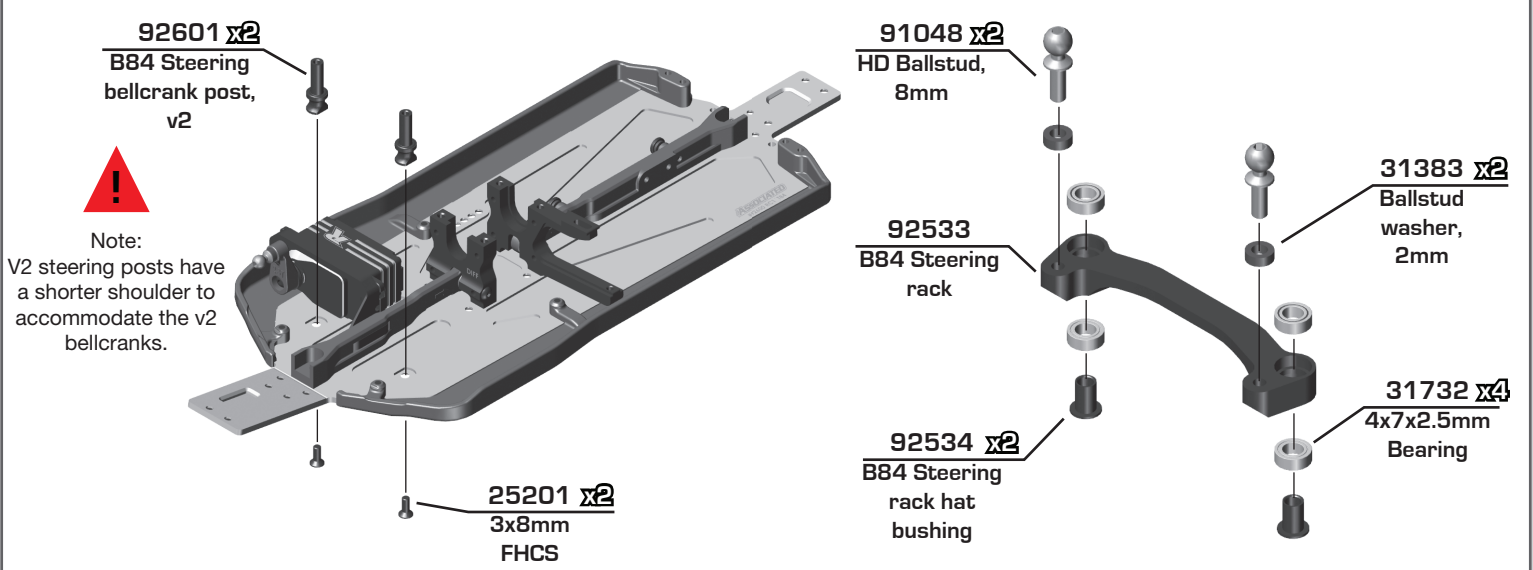

Bag 1 - Step 6

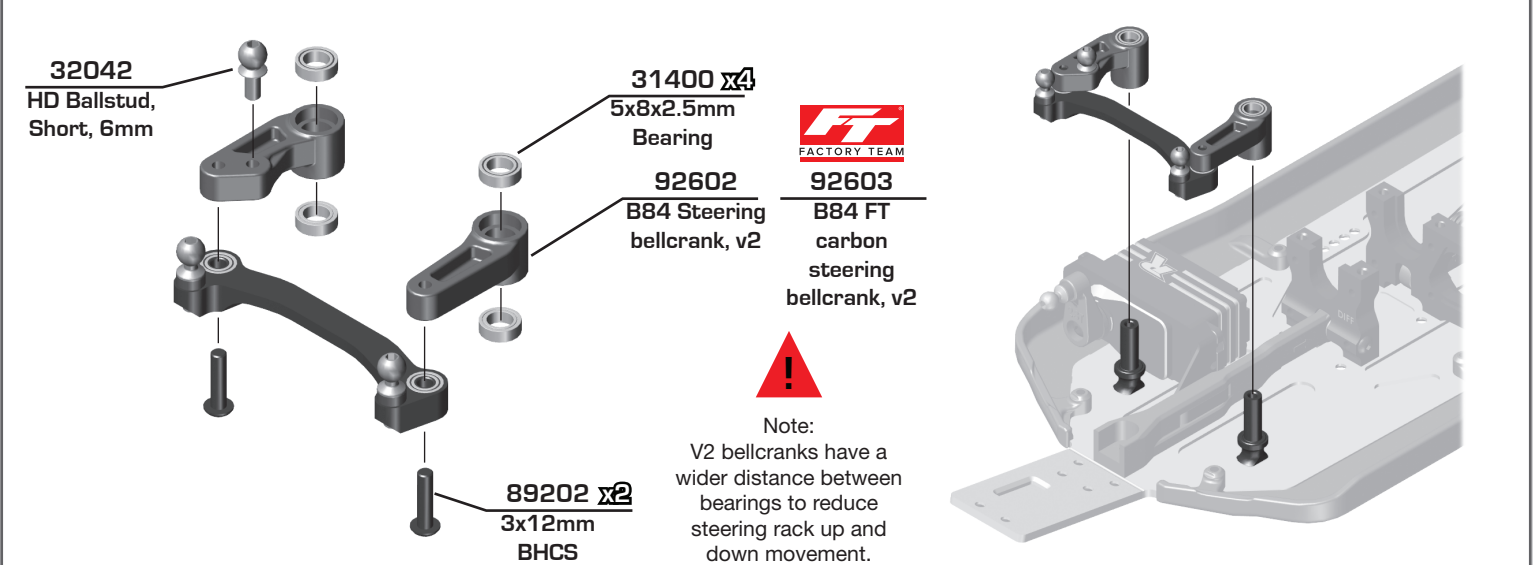

:: Bag 1 - Step 7

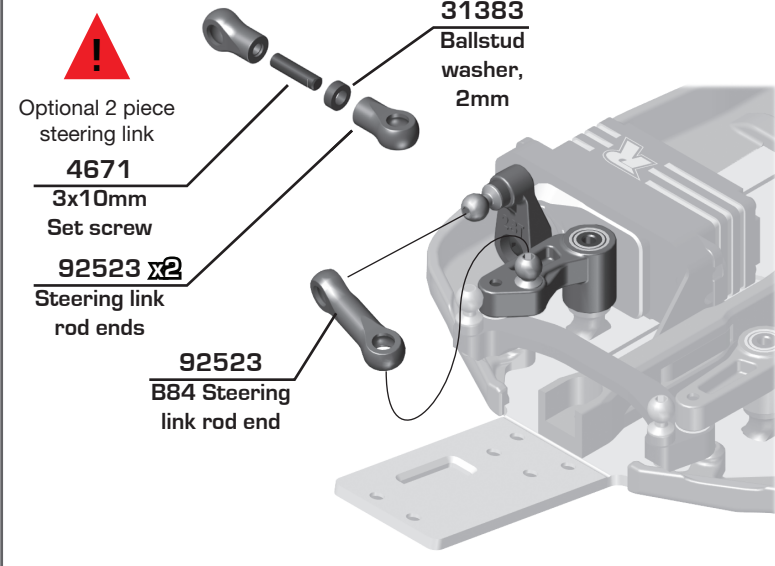

:: Bag 2 - Step 1

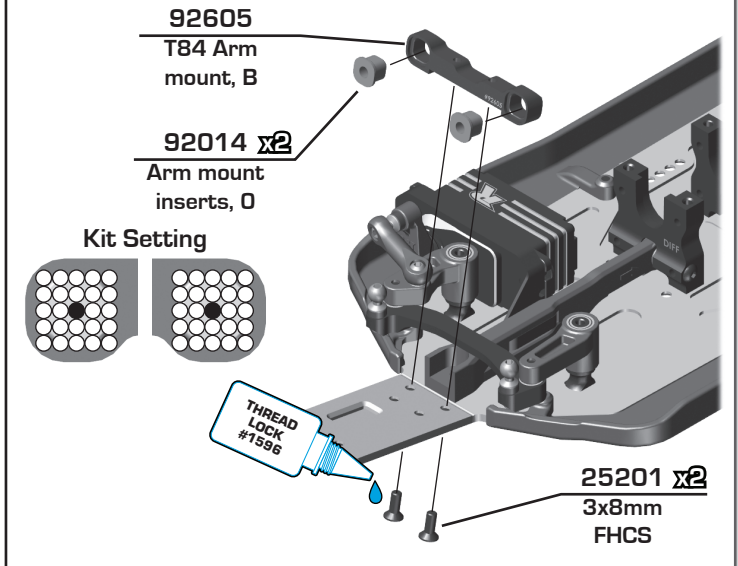

:: Bag 2 - Step 2

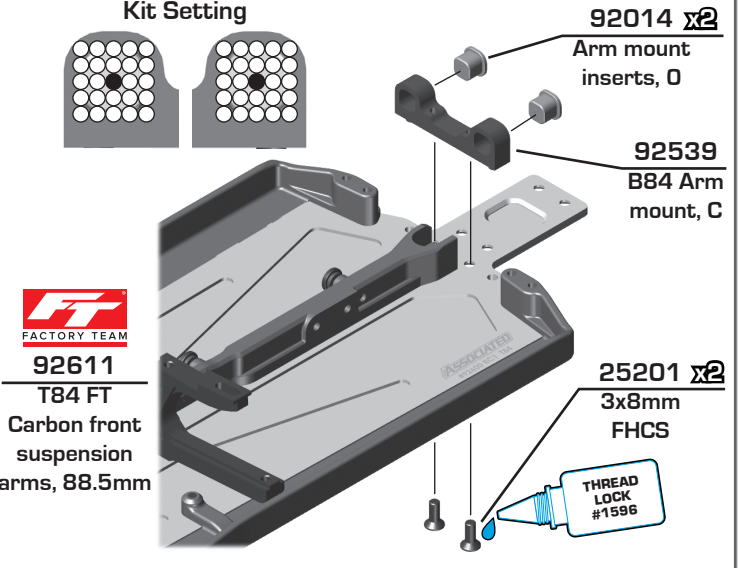
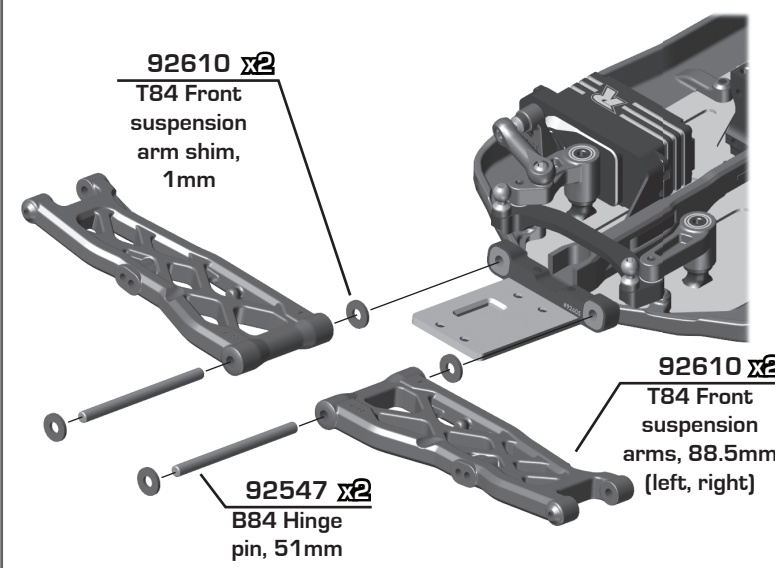

:: Bag 2 - Step 3

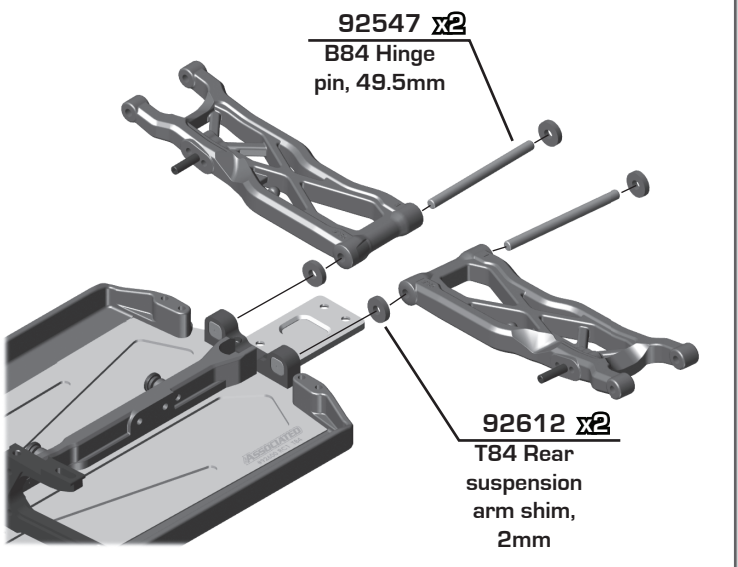
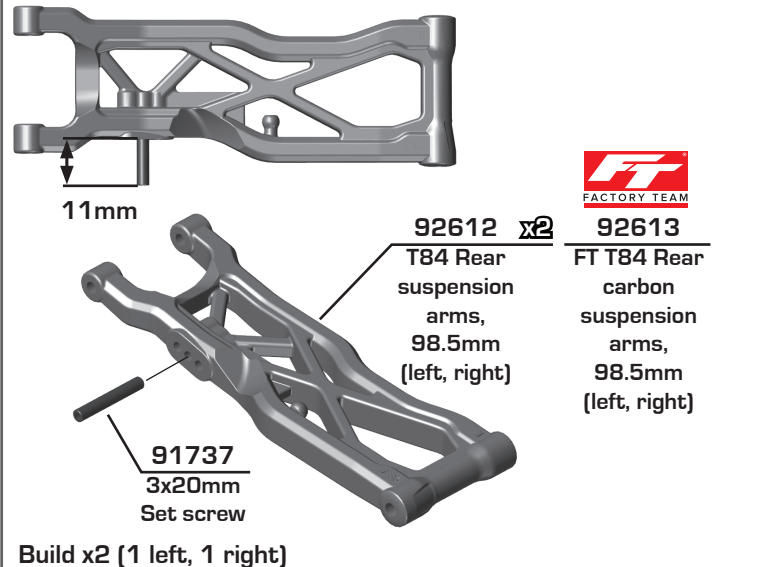

Build x2 (1 left, 1 right)

Bag 3 - Step 1

92307
5x8x0.2mm shim

92524
B84 Diff case

92133
B84 Diff O-ring

92452
B7 HD gear differential outdrives

92306
5x8x0.2mm shim

92542
B84 ring gear, 40T

92133
B84 Diff O-ring

92452
B7 HD gear differential outdrives

92138
Differential cross pins

92560
Diff sun gear, HTC, plastic

92138
Differential cross pins

92560
Diff sun gear, HTC, plastic

92560
Diff sun gear, HTC, plastic

Optional #92307, #92559, or #92306 can be interchanged with #92560

Build x2 (1 front, 1 rear)

Bag 3 - Step 2

92138 x2
Diff cross pin

92560 x4
Diff planet gear, HTC, plastic

92560 x4
2.55x6.0x0.15 shim

31472 x4
2.5x8mm FHCS

92133
Diff gasket

Be sure not to over-tighten the ring gear screws. This will lead to the gear warping.

30k Diff fluid - Front
20k Diff fluid - Rear

DIFF FLUID

Racers Tip:
Use diff shim set from the TC8 to fine tune mesh # 31396

Bag 4 - Step 1

FACTORY TEAM

92510
B84 FT Carbon front gearbox

92509
B84 Front gearbox, lower

25201 x4
3x8mm FHCS

89208
3x14mm FHCS

Kit Setting

92604
T84 Arm mount, A

92609
T84 Front bumper, tall

92541
B84 Arm mount backing plate

25188 x2
3x20mm BHCS

92014 x2
Arm mount inserts, 0

You may find it easier to install the taller front bumper after installing the anti-roll bar.

There are two front bumpers included (standard, and tall).

Bag 4 - Step 2

92264
FT CVA cup, center, aluminum

92215
Center CVA input coupler

91438
CVA barrel

92218
Center CVA bones, 64mm

91438
CVA pin

92319
Diff pinion gear shim, 5x6.5x1mm

92142
B74 Diff pinion gear, 16T

92324 x2
5x10x4mm flanged bearing

92513
B84 Diff pinion height insert, 2

92216
CVA cup, center, aluminum

Number shown on the side of the insert after insertion should match the diff height desired. Kit setup: "2"

Bag 4 - Step 3

25226
4x5mm Set screw

92143
Diff pinion gear shim

THREAD LOCK #1596

Bag 4 - Step 4

92139 x2
Diff outdrive shims

91563 x2
10x15x4mm bearing

92513 x2
B84 Diff height inserts, (kit setting +2)

89202 x4
3x12mm BHCS

92510
B84 FT Carbon front gearbox

92509
B84 Front gearbox, upper

Take extra care not to strip these screw holes out. Stripping the plastic will result in premature failure.

Start by shimming the diff with one shim on either side of the diff. If the diff is tight when inserted into the gearbox, remove one shim from the ring gear side and add it to the diff case side.

Bag 4 - Step 5

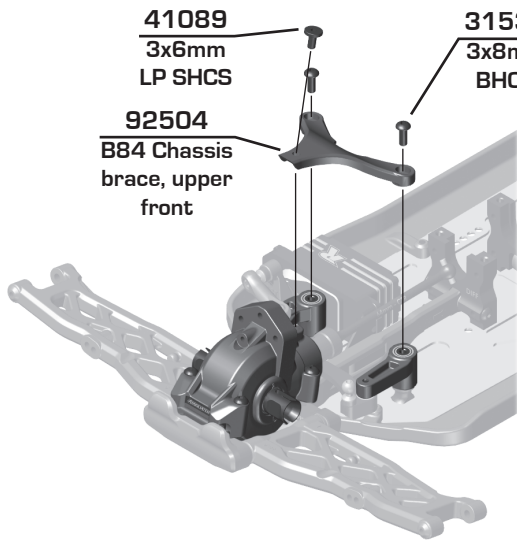

41089
3x6mm
LP SHCS

92504
B84 Chassis
brace, upper
front

31532 x2
3x8mm
BHCS



92512
B84 FT
Carbon rear
gearbox, +2

92511
B84 Rear
gearbox,
lower, +2

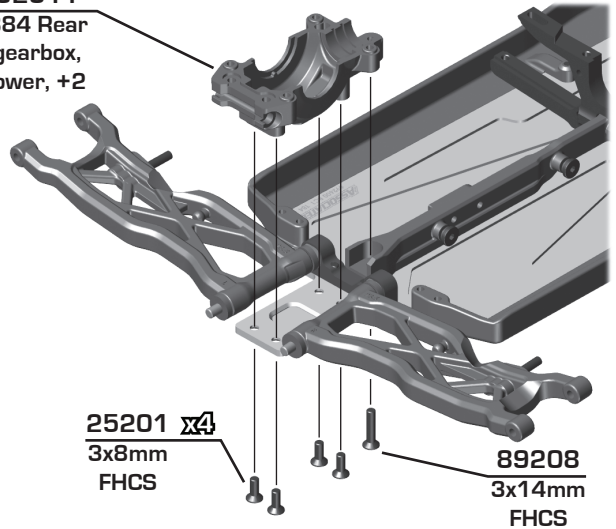

25201 x4
3x8mm
FHCS

89208
3x14mm
FHCS

Bag 4 - Step 6

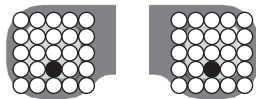

Kit Setting

92541
B84 Arm
mount backing
plate

92540
B84 Arm
mount, D

92525
B84 Rear
bumper

25188 x2
3x20mm
BHCS

92014 x2
Arm mount
inserts, 0.5
down

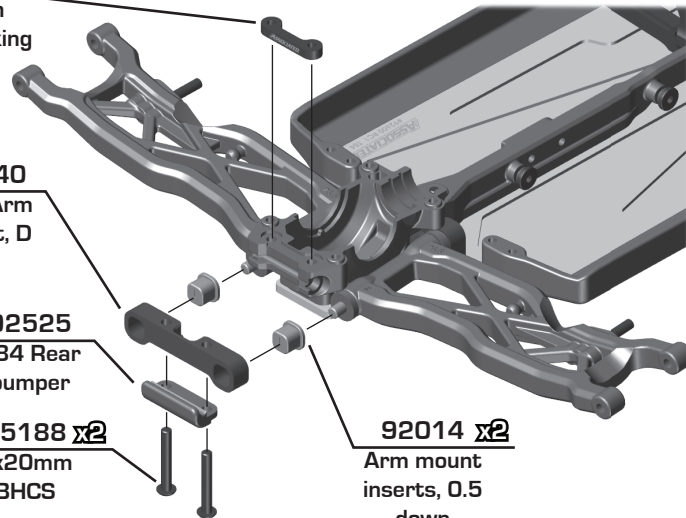

Bag 4 - Step 7

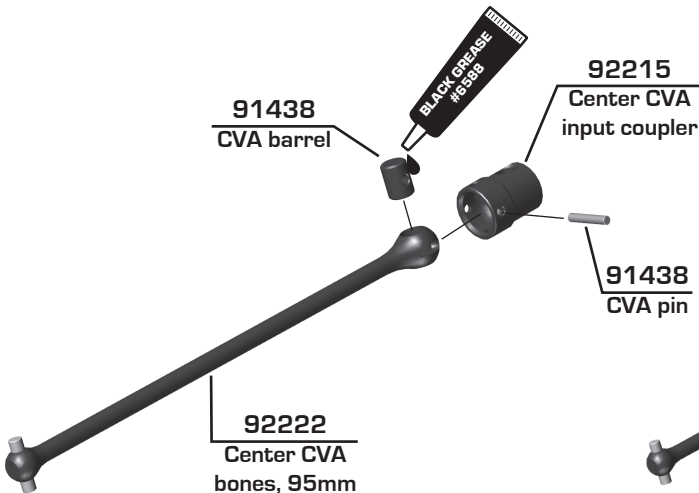

91438
CVA barrel



92215
Center CVA
input coupler

91438
CVA pin

92222
Center CVA
bones, 95mm

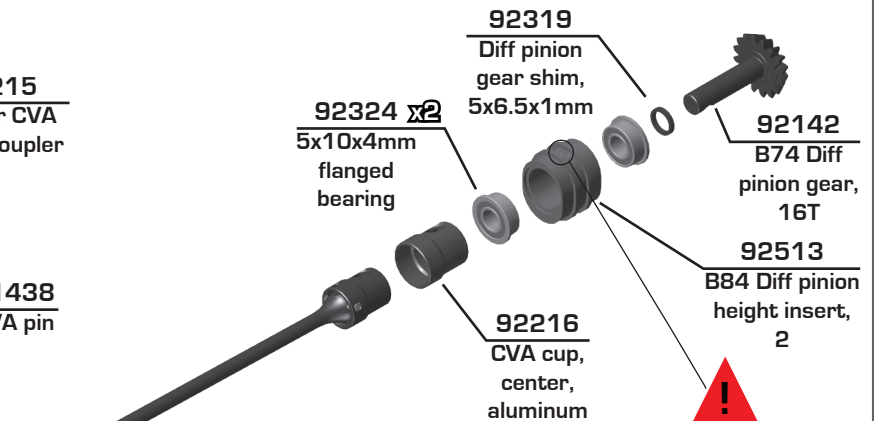

92324 x2
5x10x4mm
flanged
bearing

92319
Diff pinion
gear shim,
5x6.5x1mm

92142
B74 Diff
pinion gear,
16T

92513
B84 Diff pinion
height insert,
2

92216
CVA cup,
center,
aluminum



Number shown on the top and bottom of the rear insert after insertion should match the diff height desired. Kit setup: "2"

:: Bag 4 - Step 8

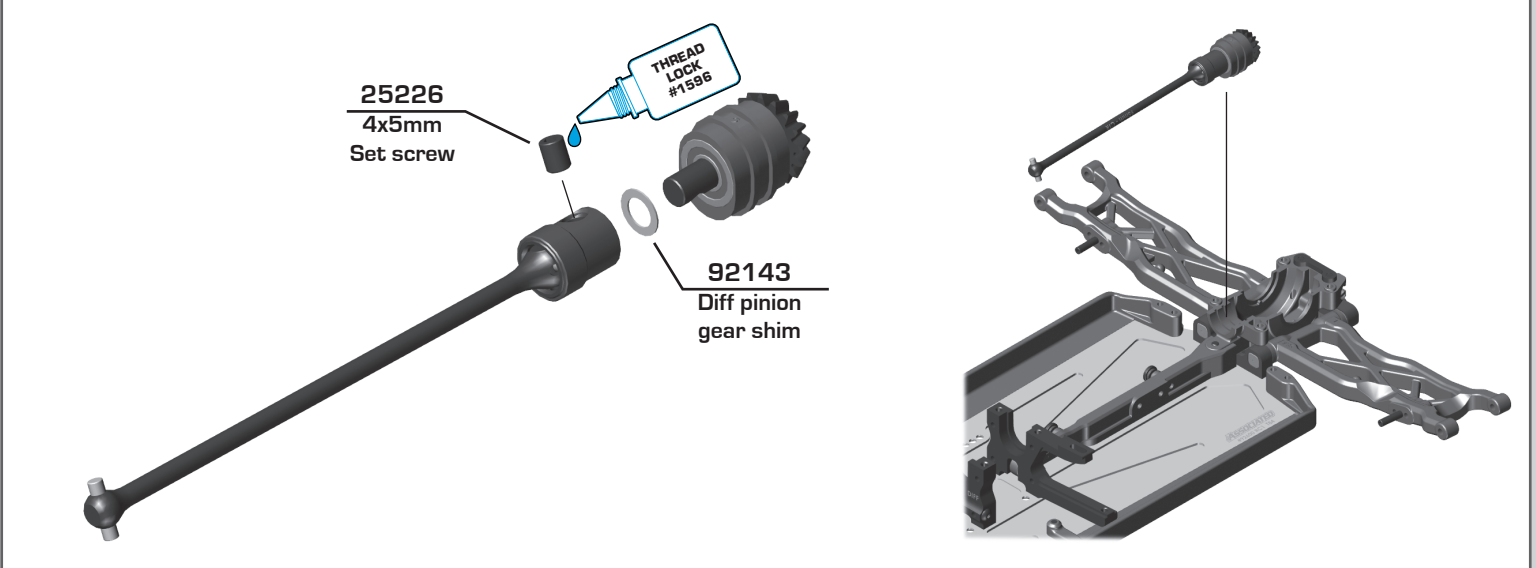

:: Bag 4 - Step 9

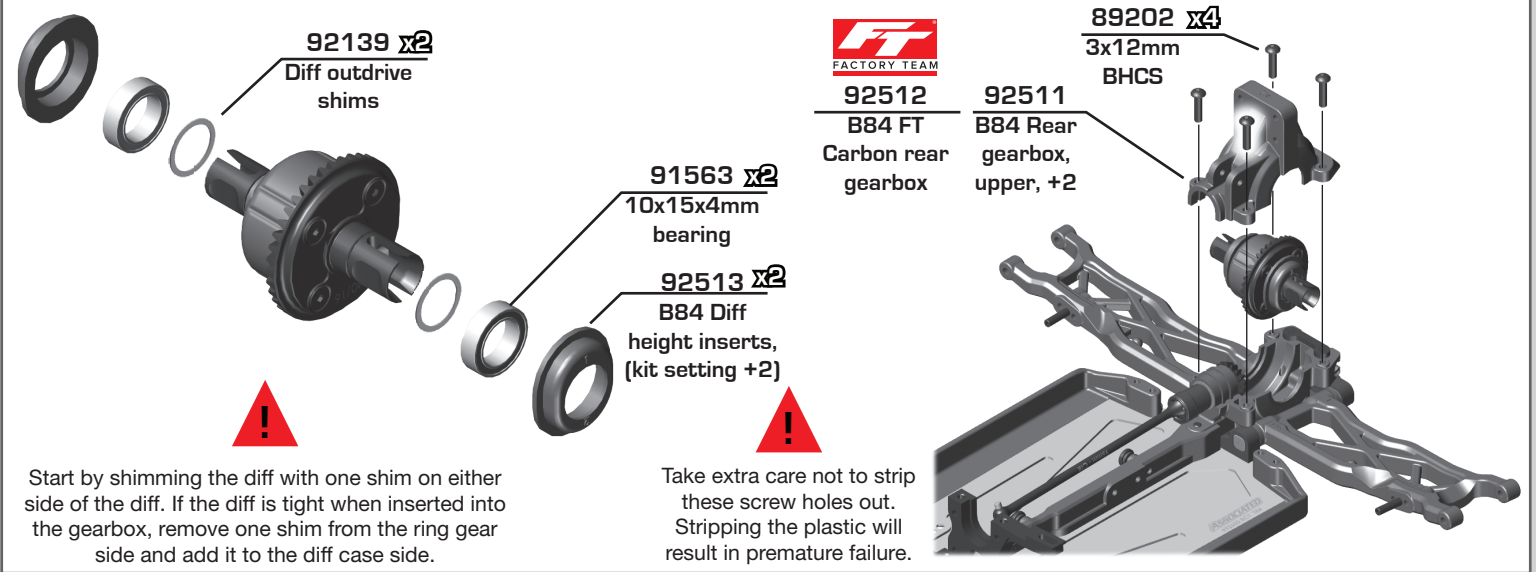

:: Bag 4 - Step 10

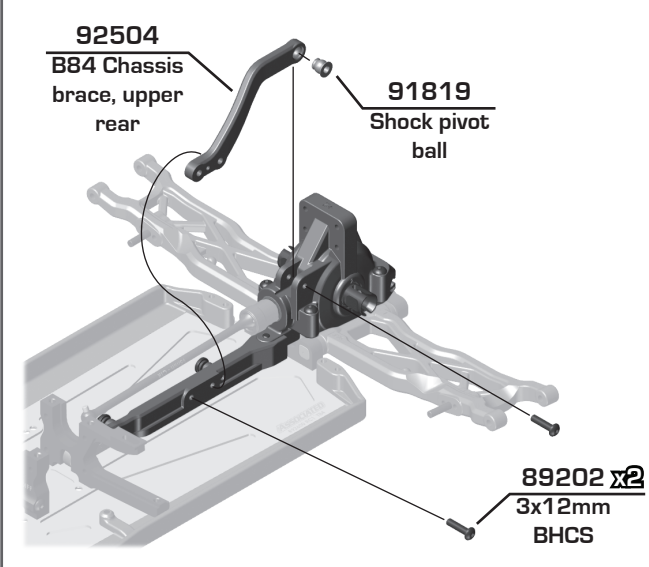

:: Bag 5 - Step 1

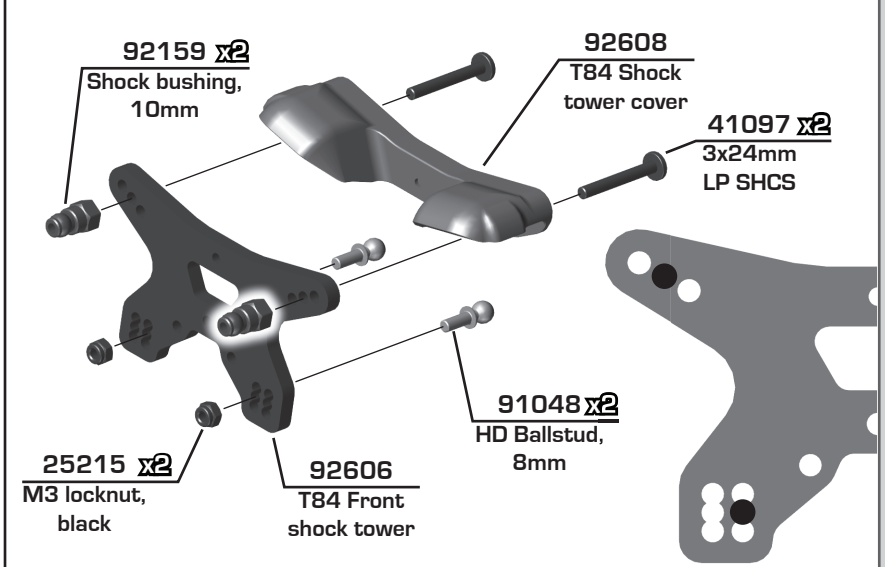

:: Bag 5 - Step 2

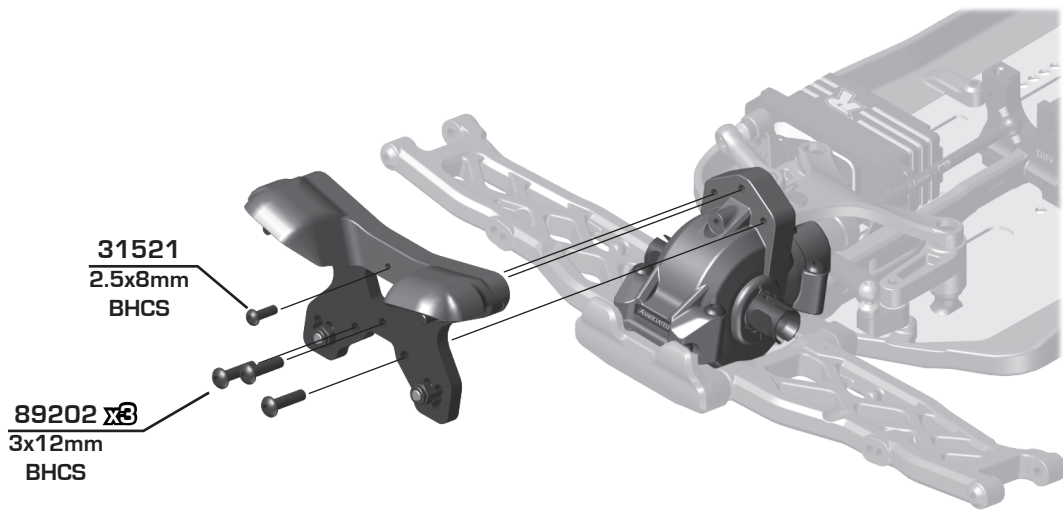

31521
2.5x8mm
BHCS

89202 x3
3x12mm
BHCS

:: Bag 5 - Step 3

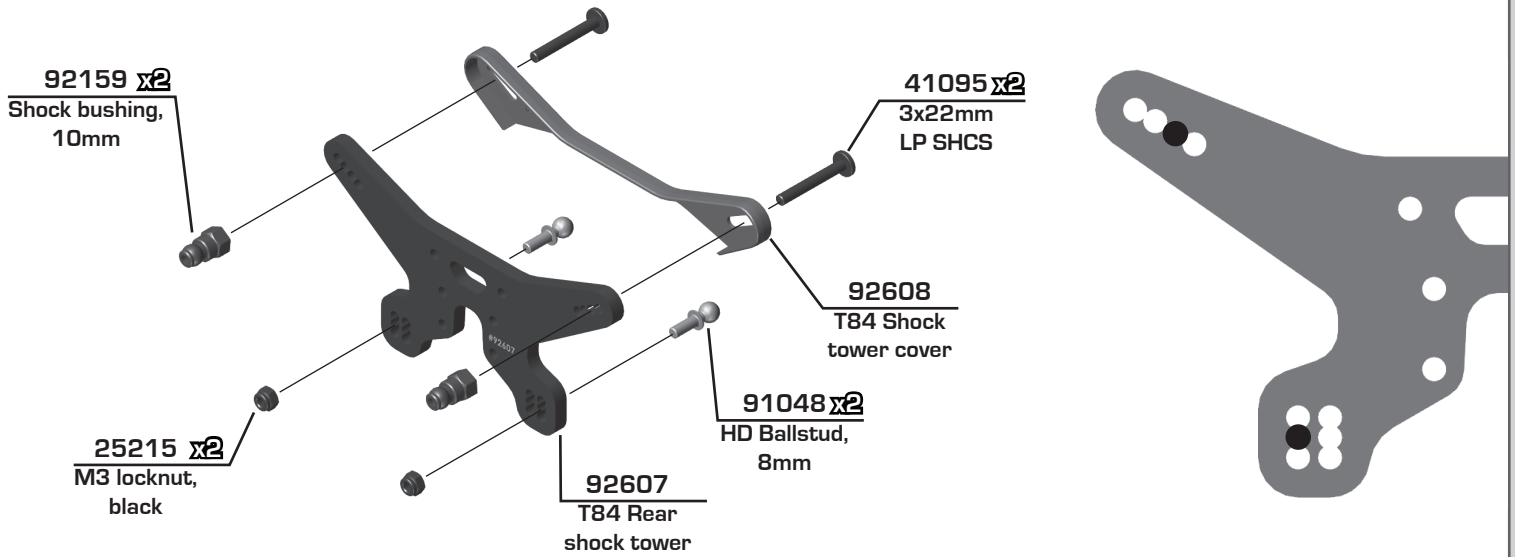

92159 x2
Shock bushing,
10mm

41095 x2
3x22mm
LP SHCS

92608
T84 Shock
tower cover

25215 x2
M3 locknut,
black

92607
T84 Rear
shock tower

91048 x2
HD Ballstud,
8mm

:: Bag 5 - Step 4

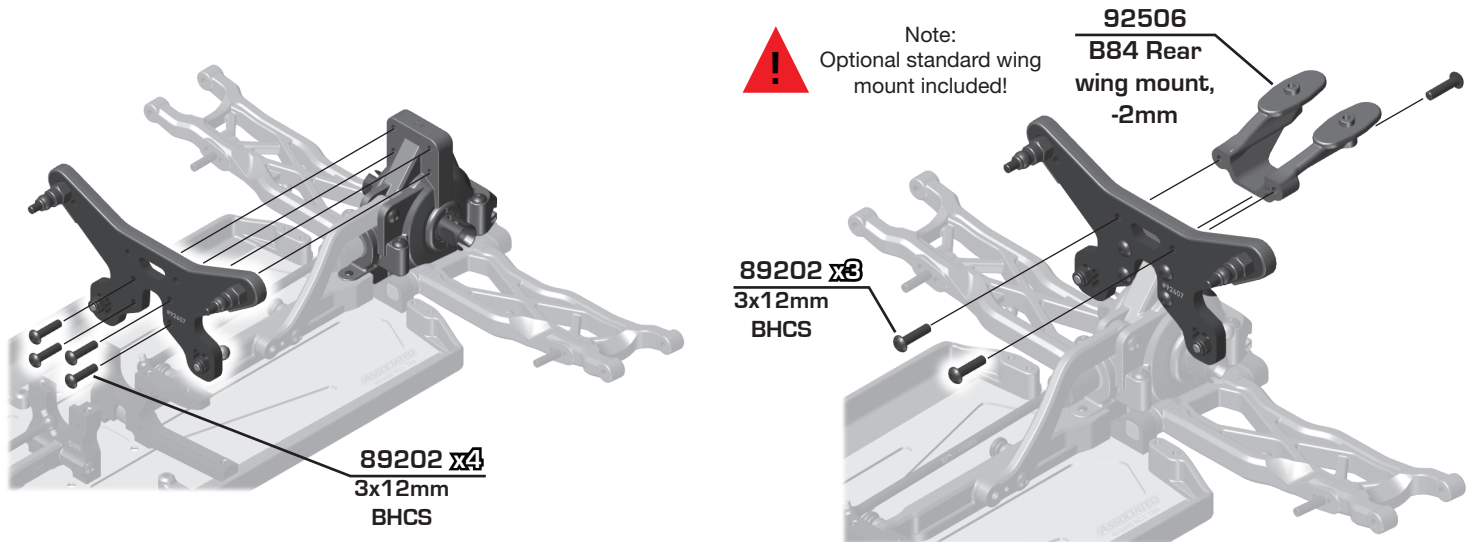

! Note:
Optional standard wing
mount included!

92506
B84 Rear
wing mount,
-2mm

89202 x3
3x12mm
BHCS

89202 x4
3x12mm
BHCS

Bag 6 - Step 1

91047 HD Ballstud, 6mm

31532 x2 3x8mm BHCS

92376 Steering block arm, (kit setting)+2

25215 M3 locknut

91560 5x10x4mm bearing

Thick

Thin

91676 Caster Hat Bushings

Build x2 (1 left side, 1 right side)

92171 Steering blocks

32043 Axle crush tubes, 5.6mm

91567 5x12x4mm bearing

91047 HD Ballstud, 6mm

31383 Ballstud washer, 2mm

92535 B84 Caster block (left)

25225 3x3mm Set screw

92522 B84 Caster inserts, "+2 °"

89202 x2 3x12mm BHCS

! There are three caster block inserts included (0°, +/- 1°, +/- 2°). 0° is the standard insert used. Tab up = adds caster Tab down = removes caster

Bag 6 - Step 2

91438 CVA barrel

BLACK GREASE #8588

71203 CVA bones, 92.5mm

92616 T84 Front CVA axle

91438 CVA pin

92263 Front CVA retainer

Bag 6 - Step 3

91436 CVA wheel hex pin

91611 1.6x5mm SHCS

91609 FT clamping wheel hex, 5.0mm

Bag 6 - Step 4

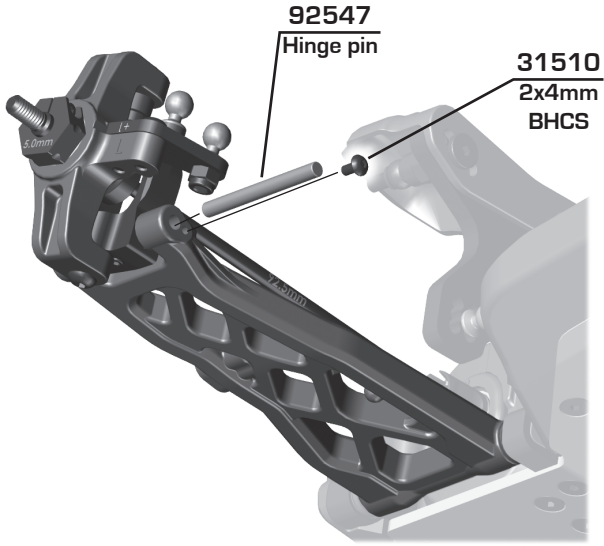

Bag 7 - Step 1

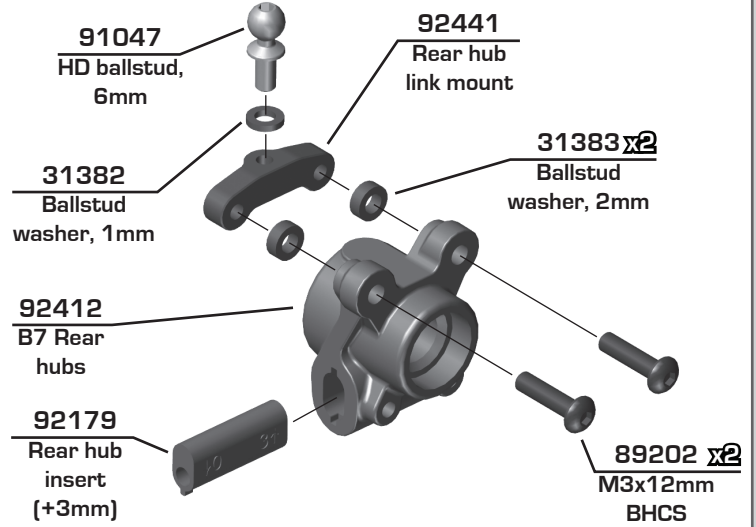

Bag 7 - Step 2

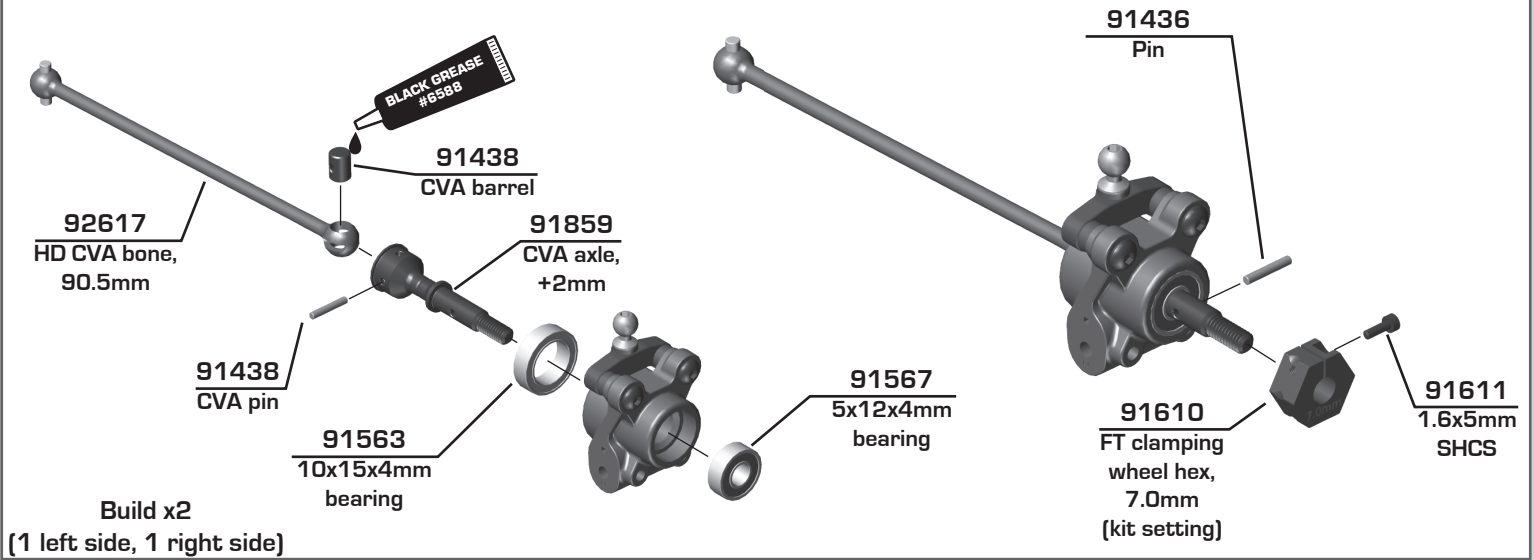

Bag 7 - Step 3

Rear Axle Height			
	↓ 0	3 ↑	+3mm
	↓ 1	2 ↑	+2mm
	↑ 1	2 ↓	+1mm
	↑ 0	3 ↓	+0mm

Build x2
(1 left side, 1 right side)

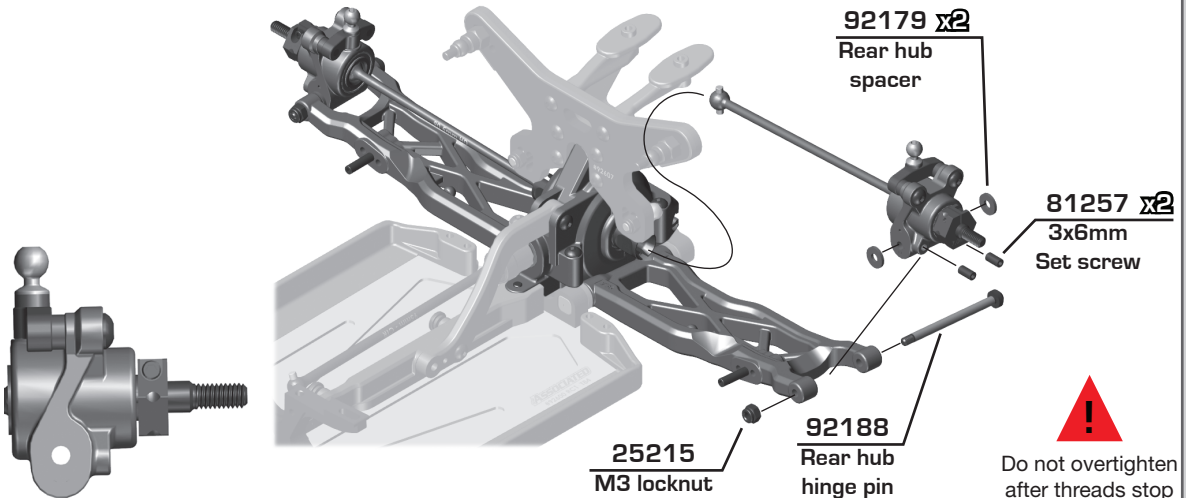

:: Bag 8 - Step 1

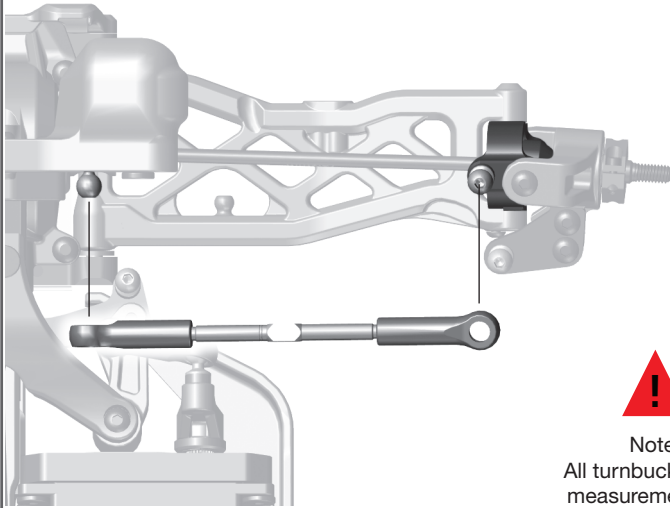

92308 x2
Ballcup,
straight



92351
FT Titanium
turnbuckle
3.5x58mm

92339
3.5x58mm
turnbuckle



Orient the notch to the left throughout the car. It indicates which end has the left hand threads!



Note:
All turnbuckle inner measurements are approximate.

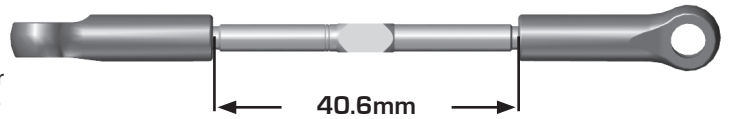

Build x2 (1 left side, 1 right side)

:: Bag 8 - Step 2

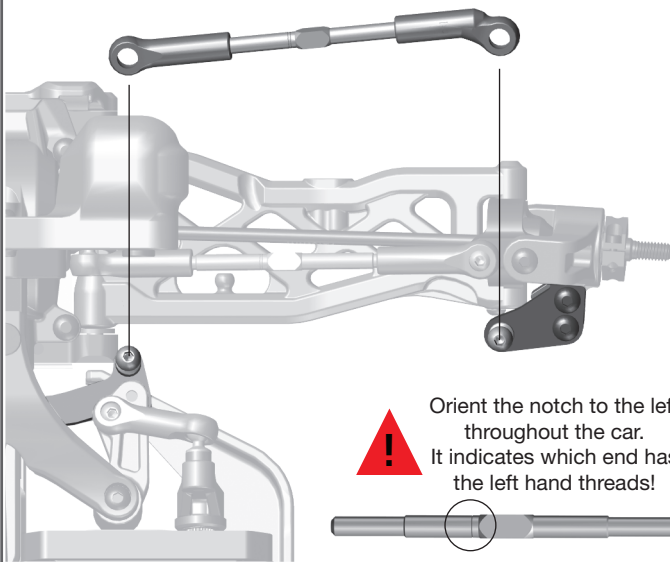

92308
Ballcup,
straight



92351
FT Titanium
turnbuckle
3.5x58mm

92339
3.5x58mm
turnbuckle

92308
Ballcup,
Offset



There is two offset ballcups labeled "1" and "2". The ballcup labeled "1" goes on the left side of the car.



Orient the notch to the left throughout the car. It indicates which end has the left hand threads!



Right



Left



36mm

Build x2 (1 left side, 1 right side)

:: Bag 8 - Step 3

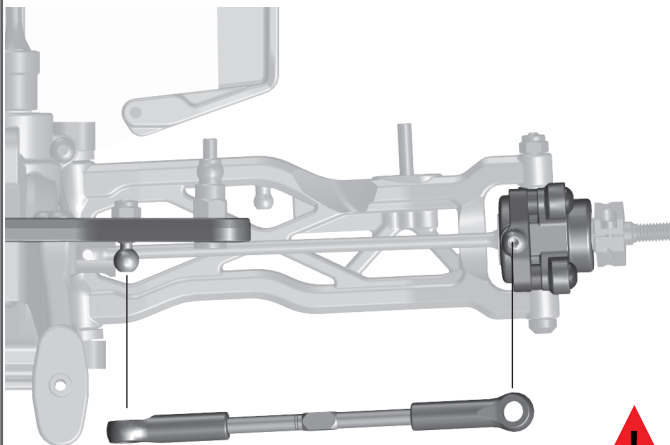

92308 x2
Ballcup,
straight



92352
FT Titanium
turnbuckle
3.5x67mm

92340
3.5x67mm
turnbuckle



Orient the notch to the left throughout the car. It indicates which end has the left hand threads!

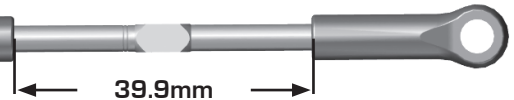

Build x2 (1 left side, 1 right side)

Build x2 (1 left side, 1 right side)

:: Bag 9 - Step 1

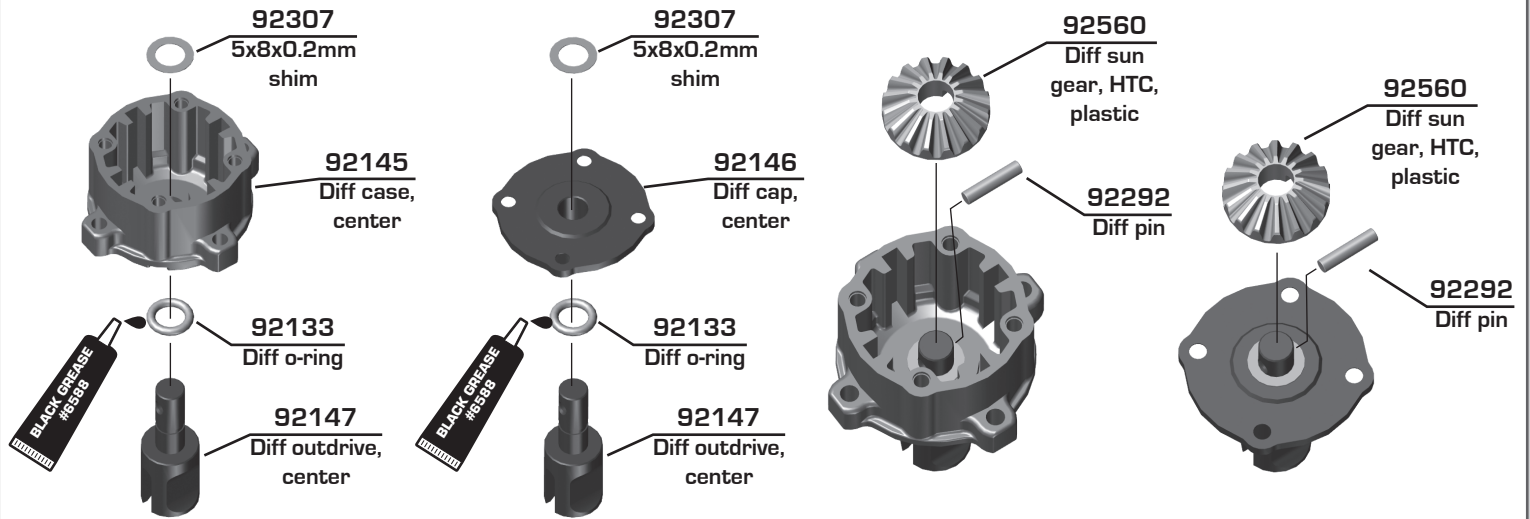

:: Bag 9 - Step 2

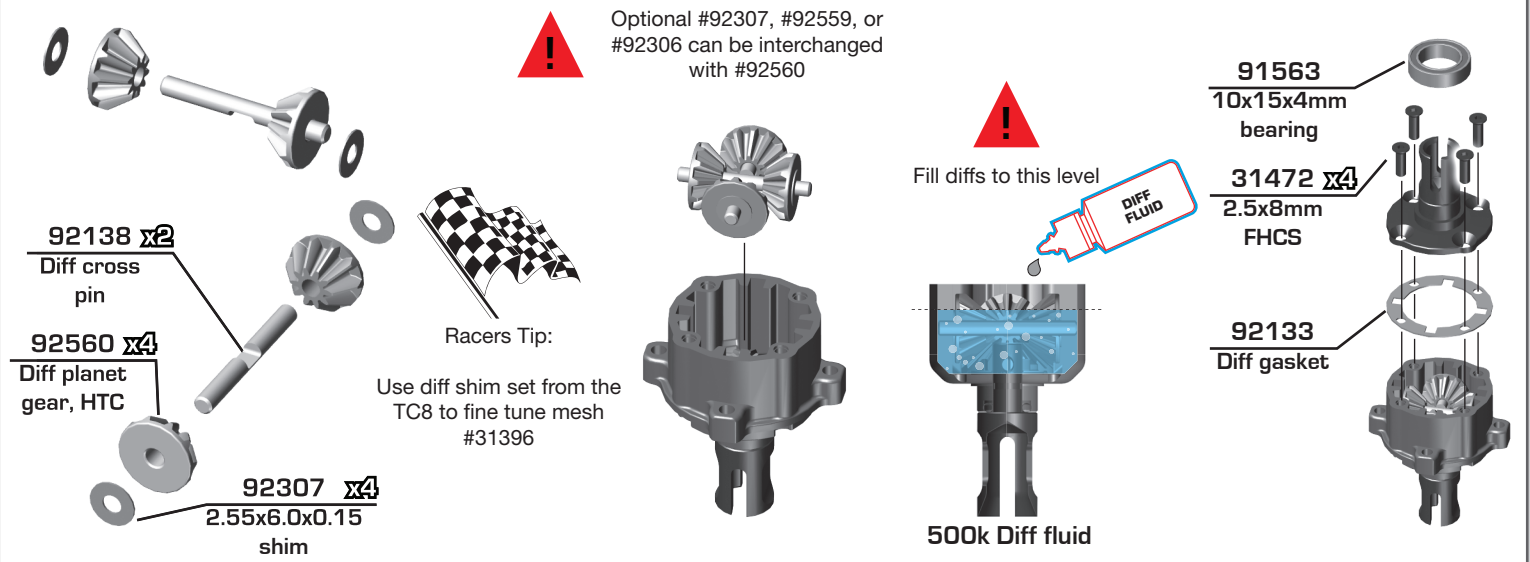

:: Bag 9 - Step 3

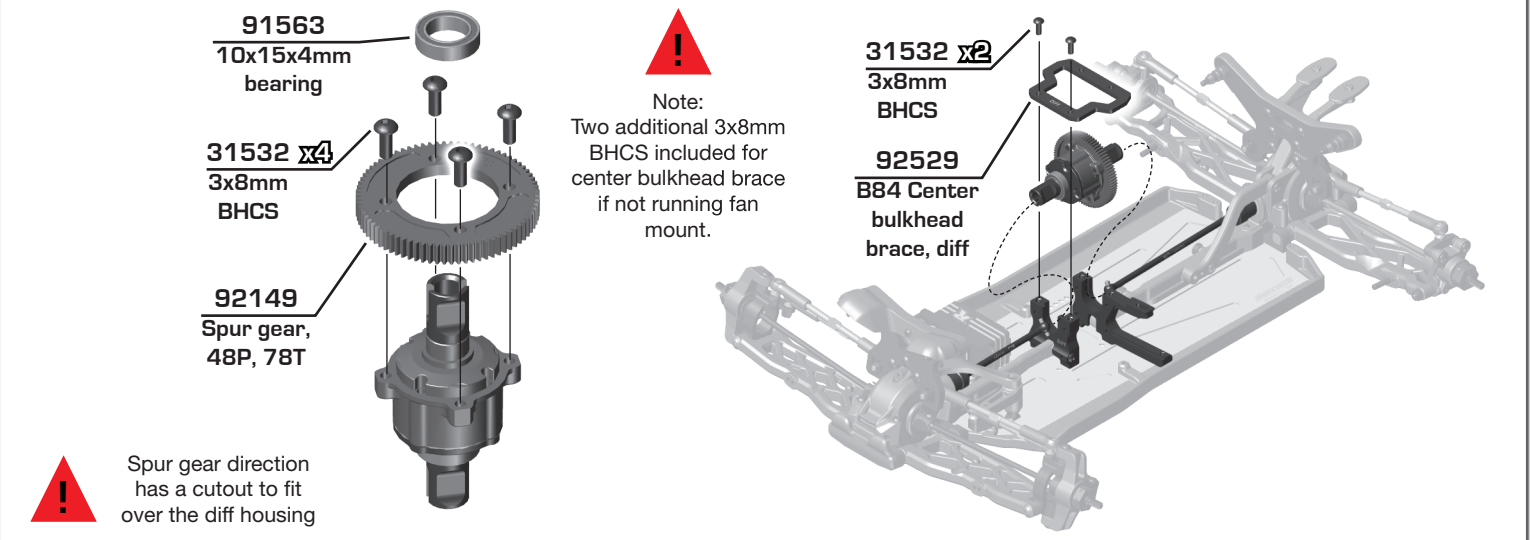

Bag 10 - Step 1

92457 x2
Anti-Roll bar pivot

92419 x2
Anti-Roll bar rod end

92457 x2
Anti-roll bar collar

31500 x4
3x2.5mm Set screw

92458
Anti-Roll bar 1.3mm

THREAD LOCK #1596

Note: Orient the set screws in the same location on left and right side.

Note: Leave some side to side movement when setting the anti-roll bar collars. The anti-roll bar should not bind the suspension

Note: The anti-roll bar rod end should be perpendicular to the suspension arm when assembled. This may require flipping the anti-roll bar pivot or adjusting it on the bar to achieve the correct setting depending on arm position.

If you pre-installed the taller front bumper, you will have to remove it before installing the front anti-roll bar.

Bag 10 - Step 2

92419 x2
Anti-Roll bar rod end

92457 x2
Anti-Roll bar pivot

92457 x2
Anti-roll bar collar

31500 x4
3x2.5mm Set screw

92458
Anti-Roll bar 1.4mm

THREAD LOCK #1596

Note: Orient the set screws in the same location on left and right side.

Note: Leave some side to side movement when setting the anti-roll bar collars. The anti-roll bar should not bind the suspension

Note: The anti-roll bar rod end should be perpendicular to the suspension arm when assembled. This may require flipping the anti-roll bar pivot or adjusting it on the bar to achieve the correct setting depending on arm position.

Bag 11 - Step 1

31510
M2x4mm BHCS

91932
FT 13mm shock piston, 2.5mm (2x1.6)

89278
M2.5mm washer

91642
V2 3x24mm shock shaft TiN "front"

31510
M2x4mm BHCS

91933
FT 13mm shock piston, 2.5mm (2x1.7)

89278
M2.5mm washer

91644
V2 3x29mm shock shaft TiN "rear"

THREAD LOCK #1596

Mount the shock pistons with the number facing up!

Racers Tip:
Use a marker over the numbers on the pistons to make them easily visible!

Build x2 front shocks

Build x2 rear shocks

Bag 11 - Step 2

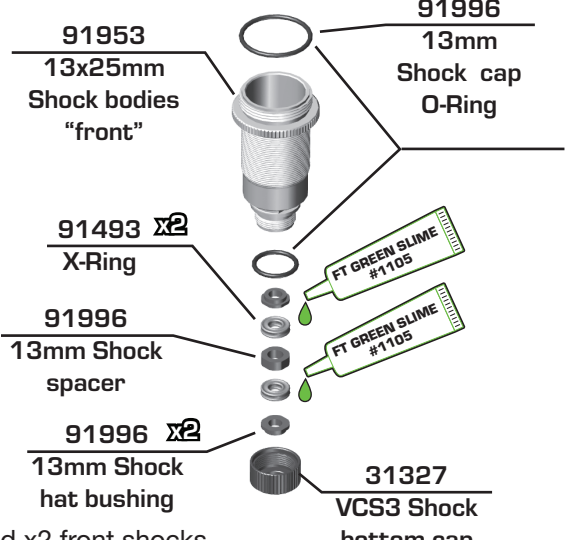

91953
13x25mm
Shock bodies
"front"

91493 **x2**
X-Ring

91996
13mm Shock
spacer

91996 **x2**
13mm Shock
hat bushing

31327
VCS3 Shock
bottom cap

91996
13mm
Shock cap
O-Ring

FT GREEN SLIME #1105



Lightly rub shock oil on the O-ring before installation!



Racers Tip:

Coating the O-rings with green slime (#1105) helps seal & reduce O-ring swell! Green slime not included in kit!

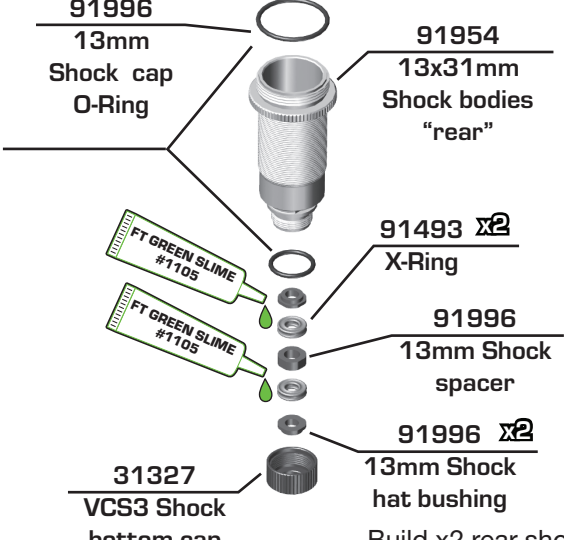

91996
13mm
Shock cap
O-Ring

91954
13x31mm
Shock bodies
"rear"

91493 **x2**
X-Ring

91996
13mm Shock
spacer

91996 **x2**
13mm Shock
hat bushing

31327
VCS3 Shock
bottom cap

FT GREEN SLIME #1105

Build x2 front shocks

Build x2 rear shocks

Bag 11 - Step 3

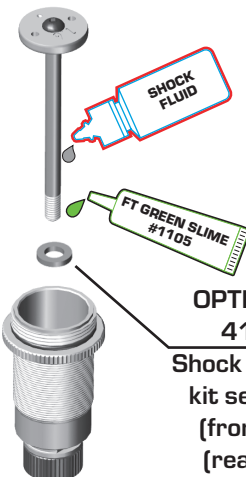

OPTIONAL
4187
Shock limiters
kit settings
(front - 0)
(rear - 0)



Lightly rub shock fluid or green slime on threads



There are 3 lengths of shock eyelet in the kit. Pay attention to length when building as these affect your droop and uptravel.



0mm



+2mm



+4mm

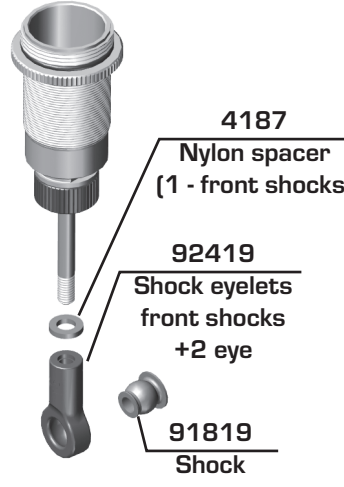

4187
Nylon spacer
(1 - front shocks)

92419
Shock eyelets
front shocks
+2 eye

91819
Shock
pivot ball

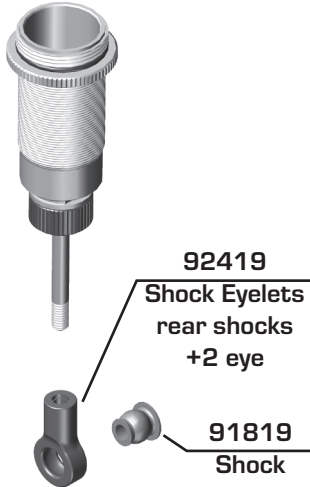

92419
Shock Eyelets
rear shocks
+2 eye

91819
Shock
pivot ball

Build x2 front shocks

Build x2 rear shocks

Bag 11 - Step 4

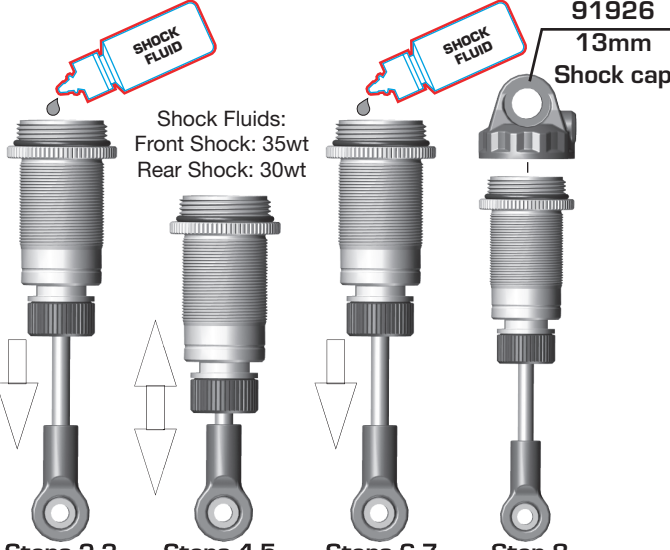

Shock Fluids:
Front Shock: 35wt
Rear Shock: 30wt

91926
13mm
Shock cap

31510
2x4mm
BHCS

Steps 2-3 Steps 4-5 Steps 6-7 Step 8

Shock Bleeding Steps:

1. Before assembly, get each bleed screw and thread it 1-2 turns into the shock cap, then remove the screw. This will make it easier when you are bleeding your shocks.
2. Pull shock shaft down.
3. Fill shock body 3/4 full with silicone shock fluid.
4. Slowly move the shock shaft up and down to remove air from under the piston.
5. Wait for bubbles to come to surface.
6. Fill shock body to top with silicone shock fluid.
7. Place a drop of oil in the cap and on cap threads.
8. Install cap (without bleed screw) and tighten completely.
9. Slowly compress shaft all the way to bleed excess silicone shock fluid out the hole in the cap (use rag around shock to catch excess fluid).
10. Install M2x4mm button head screw until snug while shaft is fully compressed.

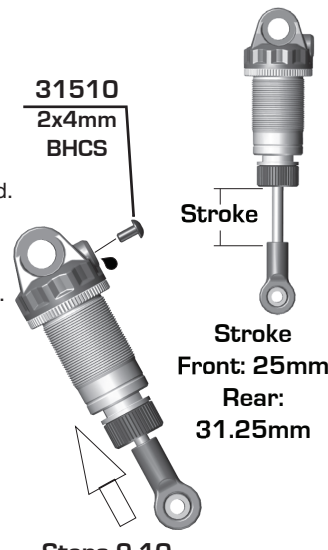

Stroke
Front: 25mm
Rear:
31.25mm

Steps 9-10

:: Bag 11 - Step 5

91996 **x4**
13mm
Threaded
collar
O-ring

91928 **x4**
13mm
Threaded
collar

91945
13mm Front
spring, orange
(4.30lb)

Racers Tip:
Use your finger to rub shock
fluid on the O-ring for smoother
adjustment!

91957
13mm Rear
spring, red
(2.40lb)

Build x4

:: Bag 11 - Step 6

Set height
after
assembly

#91966 13mm Shock Spring Cups
0mm 5mm 9mm

91926
13mm Shock
spring cup
"front - 5mm"

91966
13mm Shock
spring cup
"rear - 5mm"

Hold shock mounting
hardware until after
anti-roll bar installation.

Build x2 front shocks

Build x2 rear shocks

:: Bag 11 - Step 7

Install x2 front and x2 rear shocks

25612 **x2**
M3 flanged
nut, black

25187
M3x14mm
BHCS

Bag 12 - Step 1

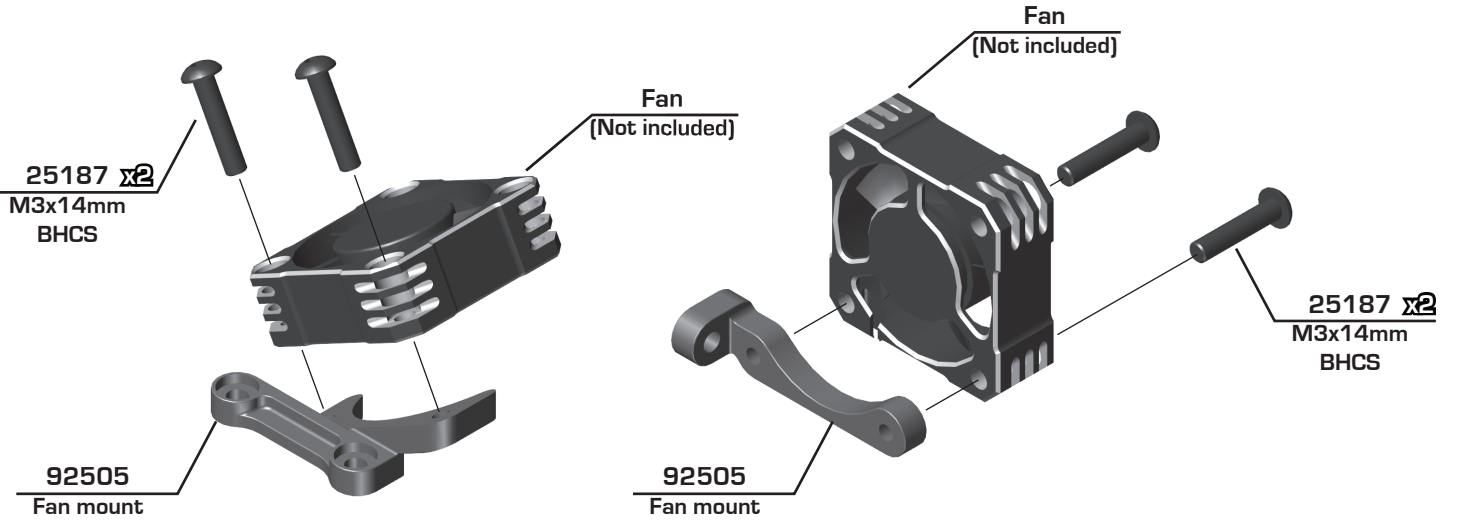

Bag 12 - Step 2

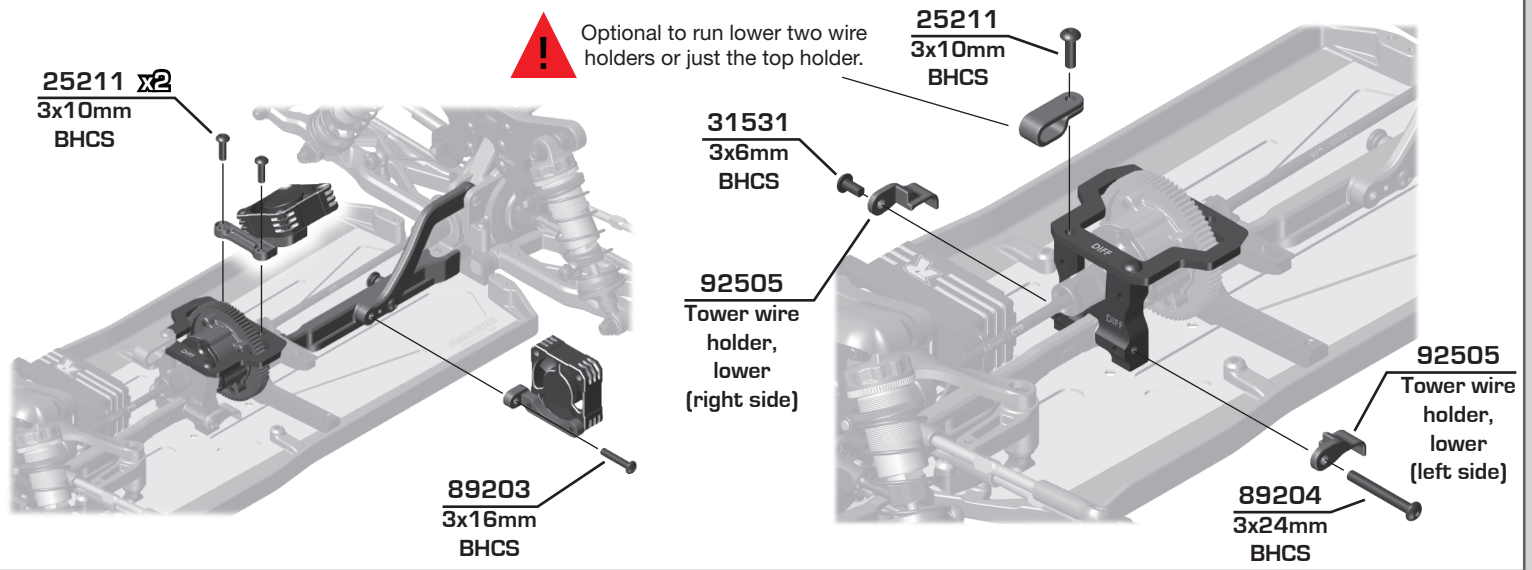

Bag 12 - Step 3

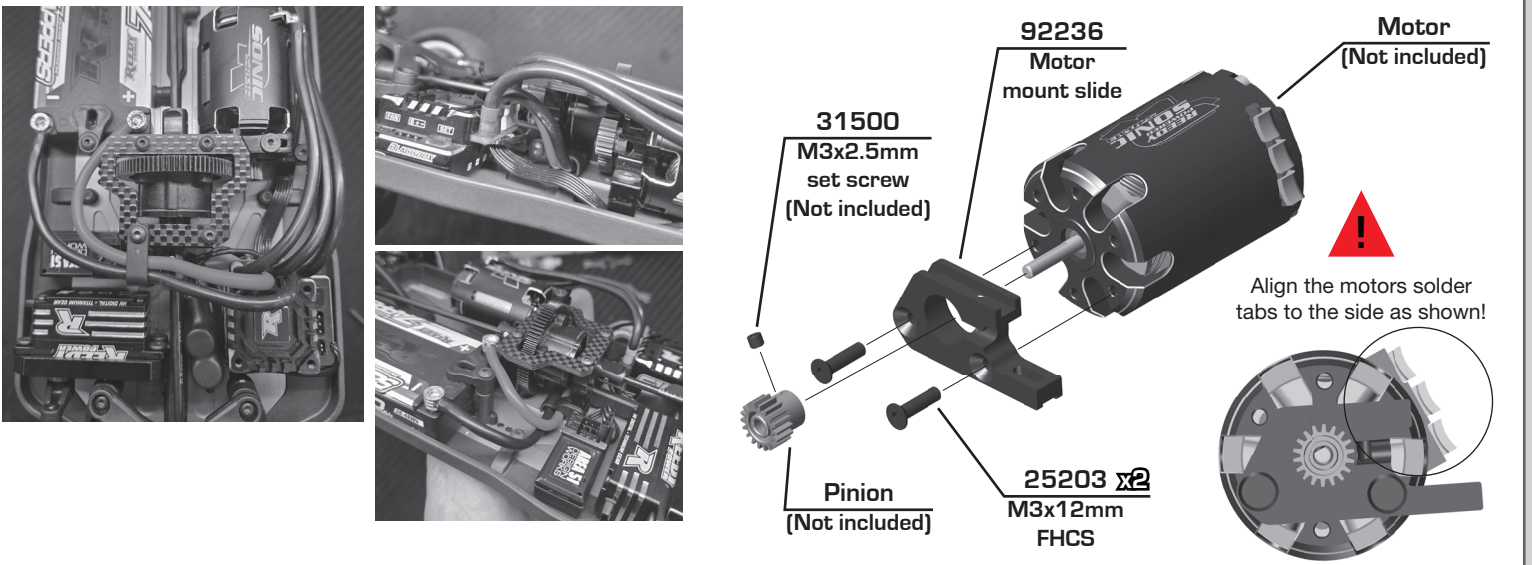

:: Bag 12 - Step 4

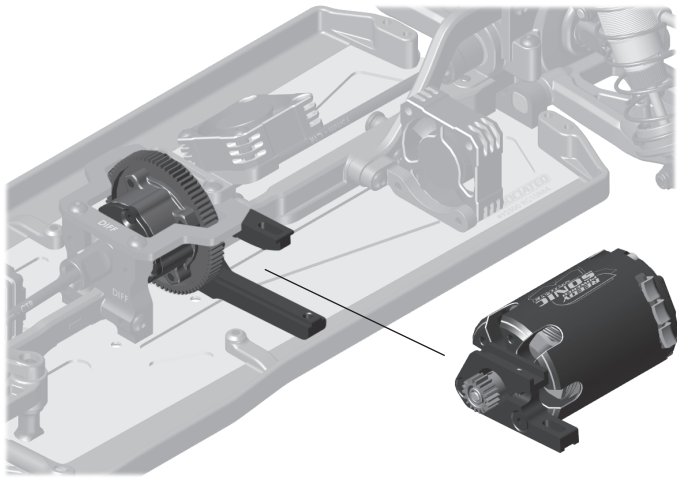

41090 x2
M3x10mm
LP SHCS

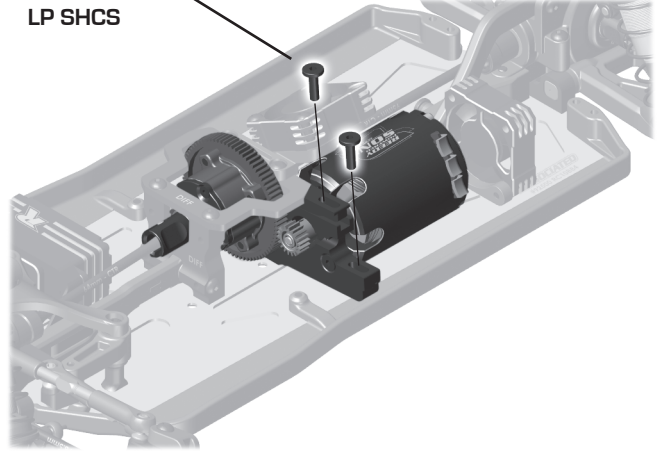

:: Bag 12 - Step 5

31532 x2
M3x8mm
BHCS

92505
B84
Battery
holder
"3"

92505
B84
Battery
holder

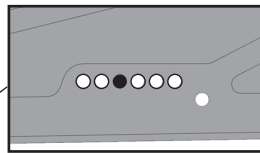
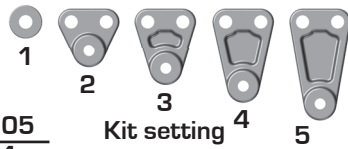

25201
M3x8mm
FHCS

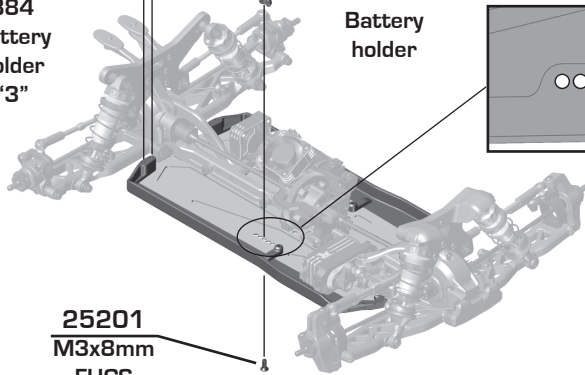

Use M3 x 20mm for
standard height
Use M3 x 14mm
LP height

25188 x2
M3x20mm
BHCS

92505
B84
Battery
holder

92463 x2
Battery
holder
O-Ring

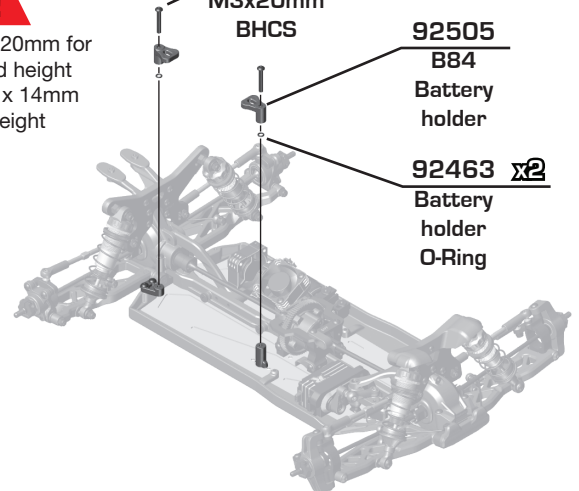

:: Bag 12 - Step 6

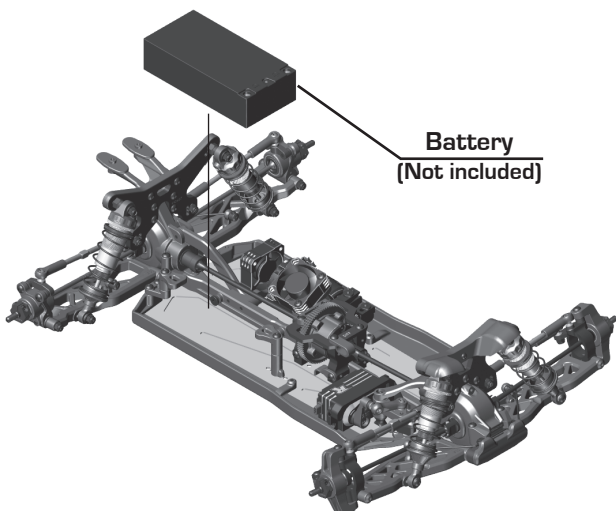

Battery
(Not included)



Bag 12 - Step 7

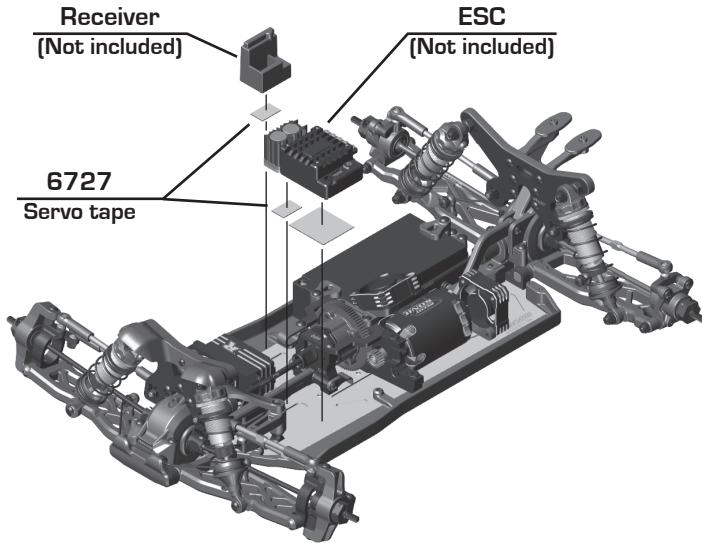

There are two cut lines on the front edge of the wing and two set of hole dimples. You can use the front cut line and the front holes or use the rear cut line and rear holes.

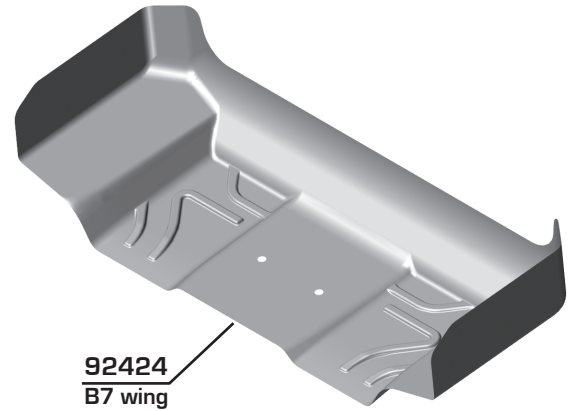

Bag 12 - Step 8

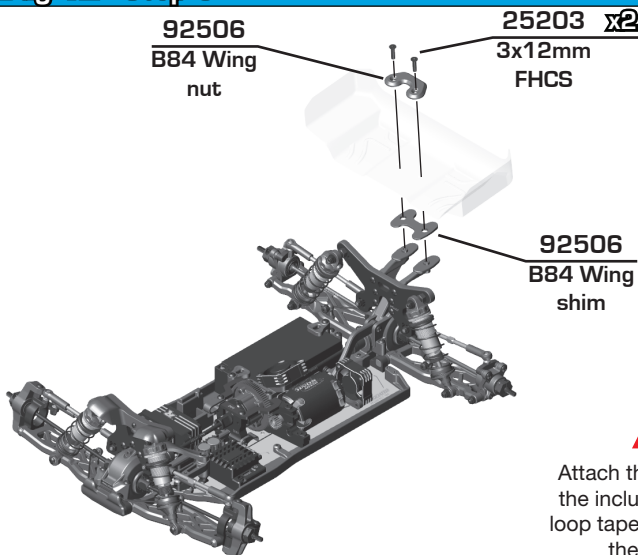

92620 FT T84 body,
(light weight)

92619 T84 body

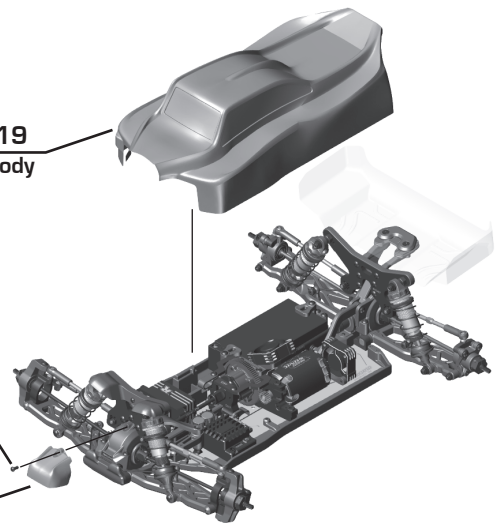

Attach the body using the included hook and loop tape to the sides of the chassis.

Bag 12 - Step 9

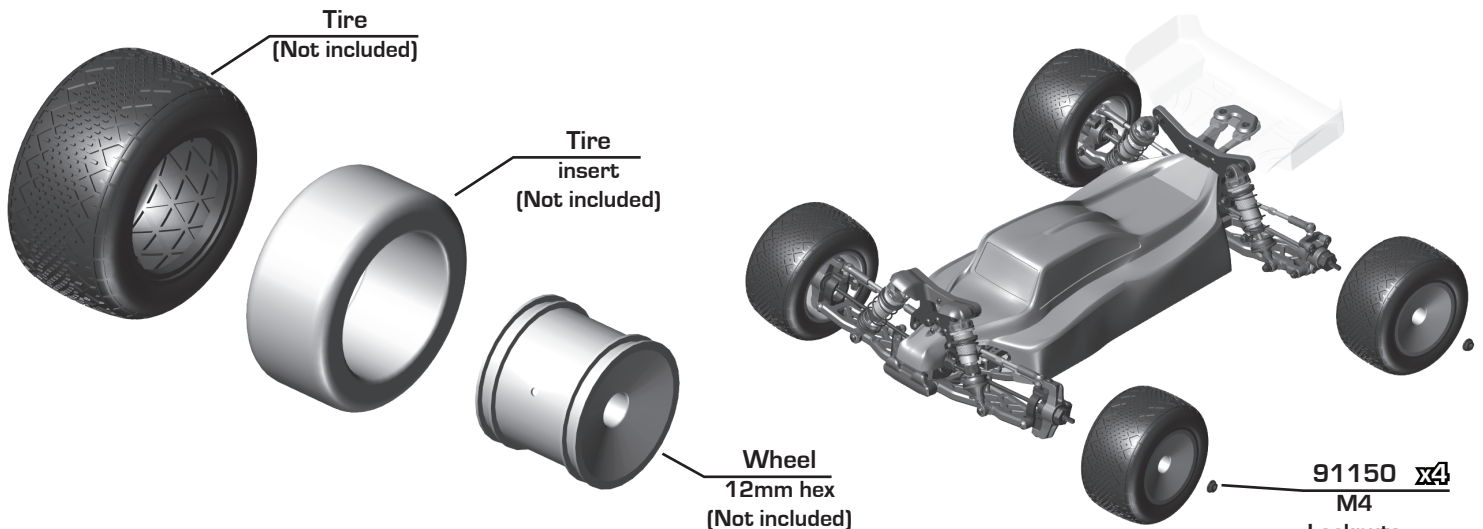

Build x2 front and x2 rear wheels/tires

⚙️ Tuning Tips - Front Arm Mount Pill Insert Setups

Standard Position

Use this position as a reference when changing pill locations.

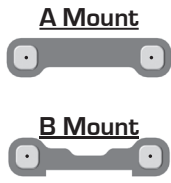

Kick-up: 10°
Roll Center: +0
Pin Width: +0

Possible Insert Locations

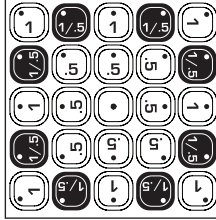

Insert Hole Locations

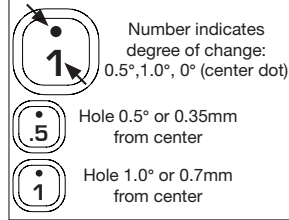

The aluminum front arm mounts utilize eccentric pill inserts to make fine adjustments to kick-up, pin height, and pin width. Adjustments can be made using the supplied inserts (#92014)

Pin Width
More distance = wider pivot
Less distance = narrower pivot

A Mount	B Mount	
		= +1.4mm
		= +0.7mm
		= 0mm
		= -0.7mm
		= -1.4mm

Pin Height
Higher pin = Higher roll center
Lower Pin = Lower roll center

A Mount	B Mount	
		= +0.7mm
		= +0.35mm
		= 0mm
		= -0.35mm
		= -0.7mm

Kick Up

More angle = More kick up
Less angle = Less kick up

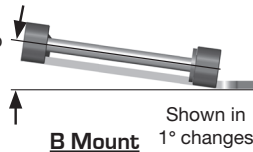

A Mount	B Mount	
		= 10°
		= 9°
		= 8°
		= 11°
		= 10°
		= 9°
		= 12°
		= 11°
		= 10°

Total Caster Angle

Total caster angle is the sum of the kick up angle and the caster block angle.

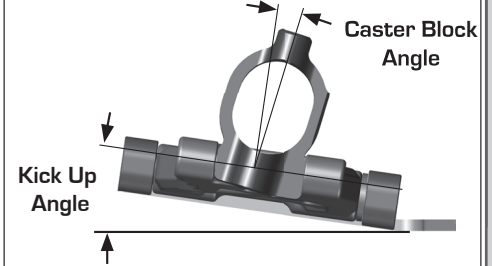

Caster Block Angle	Kick Up Angle			
	8°	9°	10°	11°
6°	14°	15°	16°	17°
7°	15°	16°	17°	18°
8°	16°	17°	18°	19°
9°	17°	18°	19°	20°
10°	18°	19°	20°	21°

⚙️ Tuning Tips - Rear Arm Mount Pill Insert Setups

Standard Position

Use this position as a reference when changing pill locations.

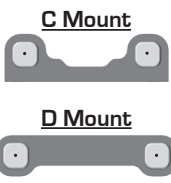

Toe: 3°
Anti-Squat: 2°
Roll Center: +0
Pin Width: +0

Possible Insert Locations

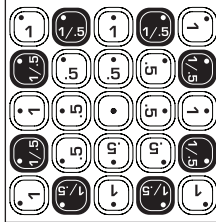

Insert Hole Locations

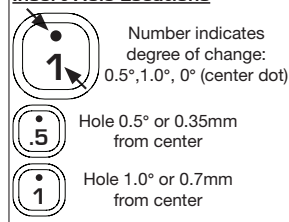

The aluminum front arm mounts utilize eccentric pill inserts to make fine adjustments to kick-up, pin height, and pin width. Adjustments can be made using the supplied inserts (#92014)

Pin Width
More distance = wider pivot
Less distance = narrower pivot

C Mount	D Mount	
		= +1.4mm
		= +0.7mm
		= 0mm
		= -0.7mm
		= -1.4mm

Pin Height
Higher pin = Higher roll center
Lower Pin = Lower roll center

C Mount	D Mount	
		= +0.7mm
		= +0.35mm
		= 0mm
		= -0.35mm
		= -0.7mm

Anti-Squat Angle

More angle = More anti-squat
Less angle = Less anti-squat

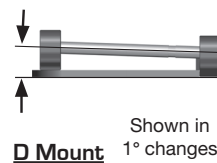

C Mount	D Mount	
		= 2°
		= 1°
		= 0°
		= 3°
		= 2°
		= 1°
		= 4°
		= 3°
		= 2°

Toe Angle

More angle = More toe in
Less angle = Less toe in
Shown in 1° changes

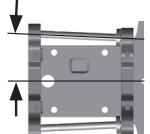

C Mount	D Mount	
		= 3°
		= 4°
		= 5°
		= 2°
		= 3°
		= 4°
		= 1°
		= 2°
		= 3°

Front Suspension:

Ride Height:	19mm
Camber:	-1 deg
Toe:	0 deg
Anti-Roll Bar:	1.3mm
Arm Type:	Kit
Tower Type:	Kit
Wheelbase Shim:	Arm Middle
Wheel Hex:	5.0mm
Steering Block Type:	B74
Caster Block:	-2° <input type="checkbox"/> -1° <input type="checkbox"/> 0° <input type="checkbox"/> +1° <input type="checkbox"/> +2° <input checked="" type="checkbox"/>
Chassis Brace Material:	Kit
Top Plate Brace Material:	Kit
Front Axles:	CVA <input checked="" type="checkbox"/> DCV <input type="checkbox"/>
Notes:	

Lower Brace Type: Fixed Pivot



Ball Stud Spacing: 2mm

Arm Mount A: 1° 0.5°
 Gray Black



Arm Mount B: 1° 0.5°
 Gray Black



Diff Height:
 +3
 +2
 +1
 +0

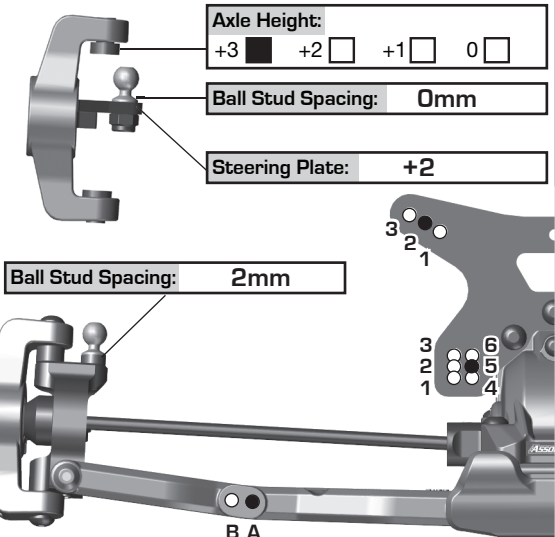

Rear Suspension:

Ride Height:	19mm
Camber:	-1 deg
Anti-Roll Bar:	1.4mm
Arm Type:	Kit
Tower Type:	Kit
Wheelbase Shim:	Arm Middle
Wheel Hex:	7.0mm
Hub Type:	Kit - B7 Standard
Drive Shaft Type:	Kit
Chassis Brace Material:	Kit
Upper Chassis Brace Material:	Kit
Hub Spacing:	Fwd <input type="checkbox"/> Mid <input checked="" type="checkbox"/> Back <input type="checkbox"/>
Notes:	

Lower Brace Type: Fixed Pivot



Rear Chassis Brace Screws:

Arm Mount C: 1° 0.5°
 Gray Black



Arm Mount D: 1° 0.5°
 Gray Black



Axle Height:
 ▼0 3▲ +3
 ▼1 2▲ +2
 ▲1 2▼ +1
 ▲0 3▼ +0

Diff Height:
 +3
 +2
 +1
 +0

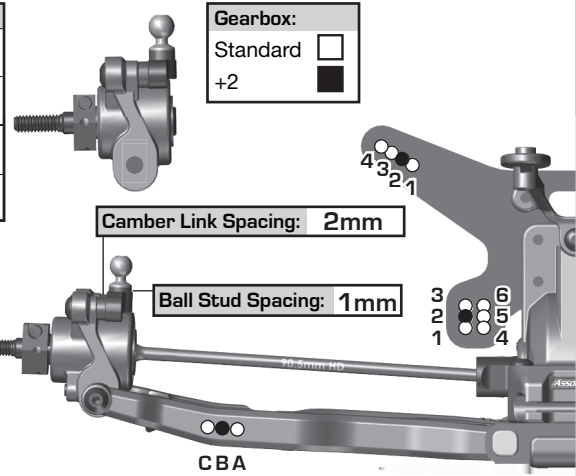

Electronics:

Radio:	Servo:
EPA: Throttle: %	Brake: %
ESC:	
ESC Settings:	
Motor / Wind:	Timing:
Pinion:	Spur:
Motor Position: Forward: <input type="checkbox"/> Back: <input checked="" type="checkbox"/>	
Battery Position: Back 1 <input type="checkbox"/> 2 <input type="checkbox"/> 3 <input checked="" type="checkbox"/> 4 <input type="checkbox"/> 5 <input type="checkbox"/> Forward	
Battery: Weight:	
Notes:	

Differential:

	Front	Center	Rear
Fluid:	30K	500K	20K
Gears:	HTC	HTC	HTC
Type:	Plastic	Plastic	Plastic
Notes:			

Slipper Clutch:

Type:
of Pads:
Setting:
Notes:

Shocks:

	Front	Rear
Piston:	2x1.6	2x1.7
Thickness:	2.5mm	2.5mm
Fluid:	35wt	30wt
Spring:	Orange	Red
Limiters: Int: 0 Ext: 1	Int: 0 Ext: 0	
Stroke:	25mm	30.25mm
Eyelet:	+2	+2
Cup Offset: 0 +5 +9	0 +5 +9	
Kashima Bodies: <input type="checkbox"/>	Chrome Shafts: <input type="checkbox"/>	Machined Spacers: <input type="checkbox"/>
Notes:		

Track Info:

Size:
Surface:
Traction:
Moisture:
Condition:
Temperature:
Notes:

Tires:

Front Tires:
Front Compound:
Front Insert:
Rear Tires:
Rear Compound:
Rear Insert:
Wheel (F/R):
Notes:

Body, Weight:

Body:	T84
Front Wing:	Nose
Rear Wing:	B7
Rear Wing Mount:	0 <input checked="" type="checkbox"/> -2 <input type="checkbox"/>
Wing Angle: 0° 3° 6°	
Chassis Length:	Standard
Total Vehicle Weight:	
Notes:	

Vehicle Comments:

Notes:

Front Suspension:

Ride Height: _____
 Camber: _____
 Toe: _____
 Anti-Roll Bar: _____
 Arm Type: _____
 Tower Type: _____
 Wheelbase Shim: _____
 Wheel Hex: _____
 Steering Block Type: _____
 Caster Block: -2° -1° 0° +1° +2°
 Chassis Brace Material: _____
 Top Plate Brace Material: _____
 Front Axles: CVA DCV
 Notes: _____

Lower Brace Type: Fixed Pivot



Ball Stud Spacing: _____

Arm Mount A: 1° 0.5°
 Gray Black



Arm Mount B: 1° 0.5°
 Gray Black



Diff Height: _____
 +3
 +2
 +1
 +0

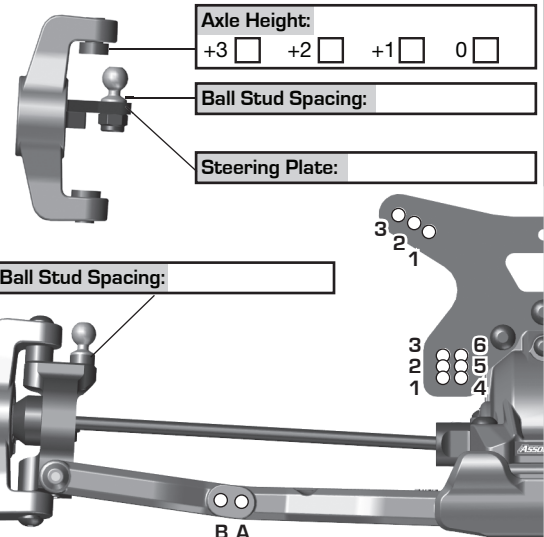

Rear Suspension:

Ride Height: _____
 Camber: _____
 Anti-Roll Bar: _____
 Arm Type: _____
 Tower Type: _____
 Wheelbase Shim: _____
 Wheel Hex: _____
 Hub Type: _____
 Drive Shaft Type: _____
 Chassis Brace Material: _____
 Upper Chassis Brace Material: _____
 Hub Spacing: Fwd Mid Back
 Notes: _____

Lower Brace Type: Fixed Pivot



Rear Chassis Brace Screws: _____

Arm Mount C: 1° 0.5°
 Gray Black



Arm Mount D: 1° 0.5°
 Gray Black



Axle Height: _____
 ▼0 3▲ +3
 ▼1 2▲ +2
 ▲1 2▼ +1
 ▲0 3▼ +0

Diff Height: _____
 +3
 +2
 +1
 +0

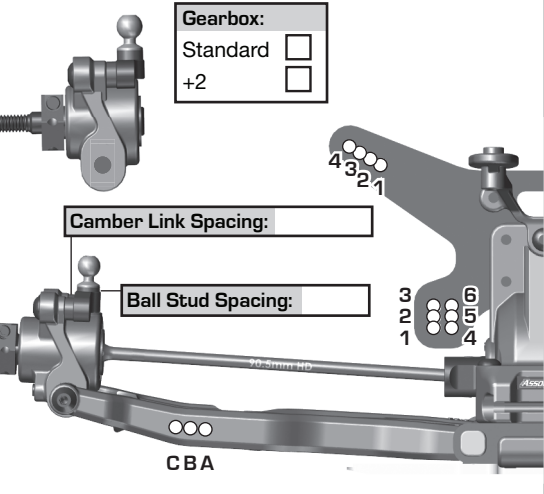

Electronics:

Radio: _____ Servo: _____
 EPA: Throttle: _____ % Brake: _____ %
 ESC: _____
 ESC Settings: _____
 Motor / Wind: _____ Timing: _____
 Pinion: _____ Spur: _____
 Motor Position: Forward: Back:
 Battery Position: _____
 Back 1 2 3 4 5 Forward
 Battery: _____ Weight: _____
 Notes: _____

Differential:

	Front	Center	Rear
Fluid:	_____	_____	_____
Gears:	_____	_____	_____
Type:	_____	_____	_____
Notes:	_____		

Slipper Clutch:

Type: _____
 # of Pads: _____
 Setting: _____
 Notes: _____

Shocks:

	Front	Rear
Piston:	_____	_____
Thickness:	_____	_____
Fluid:	_____	_____
Spring:	_____	_____
Limiters: Int: _____ Ext: _____ Int: _____ Ext: _____		
Stroke:	_____	_____
Eyelet:	_____	_____
Cup Offset: 0 <input type="checkbox"/> +5 <input type="checkbox"/> +9 <input type="checkbox"/> 0 <input type="checkbox"/> +5 <input type="checkbox"/> +9 <input type="checkbox"/>		
Kashima Bodies: <input type="checkbox"/> Chrome Shafts: <input type="checkbox"/> Machined Spacers: <input type="checkbox"/>		
Notes:	_____	

Track Info:

Size: _____
 Surface: _____
 Traction: _____
 Moisture: _____
 Condition: _____
 Temperature: _____
 Notes: _____

Tires:

Front Tires: _____
 Front Compound: _____
 Front Insert: _____
 Rear Tires: _____
 Rear Compound: _____
 Rear Insert: _____
 Wheel (F/R): _____
 Notes: _____

Body, Weight:

Body: _____
 Front Wing: _____
 Rear Wing: _____
 Rear Wing Mount: 0 -2
 Wing Angle: 0° 3° 6°
 Chassis Length: _____
 Total Vehicle Weight: _____
 Notes: _____

Vehicle Comments:

Notes: _____



Associated Electrics, Inc.
21062 Bake Parkway Lake Forest, CA 92630 USA

call: (949) 544-7500 - fax: (949) 544-7501
Check out the following web sites for all of our kits, current products,
new releases, setup help, tips, and racing info!
www.AssociatedElectrics.com

FOLLOW US ON SOCIAL MEDIA



TeamAssociated
ReedyPower
ElementRC
FactoryTeam51



@TeamAssociatedRC
@ReedyPower
@Element_RC
@FactoryTeam_RC



@Team_Associated
@ReedyPower



@Associated_Electrics



TeamAssociatedRC
ElementRC



TeamAssociated
Reedy
Element-rc