

Front Suspension:

Reset Forms

Ride Height:	17 mm (Body Off)
Camber:	-2°
Toe:	0°
Anti-Roll Bar:	#71128 1.4 mm
Arm Type:	#71139 FT Carbon, Gullwing
Tower Type:	Factory Foote T6.4 Buggy Shocks
Wheel Hex:	#71112 FT Titanium Axles, 8.5 mm
Steering Block:	4 mm Trailing
Caster Block Insert:	0°
Bulkhead Type:	#91898 FT Steel, +2.5°
Kick-Up Angle:	25° @ The Wheel
Notes:	#71183 FT Carbon Angled Top Plate #91985 Carbon Caster & Steering Blocks

Bump Steer Spacing:	0 mm
Steering Plate:	#91902 FT HT +1
Steering Stop Spacing:	None
Caster Block Spacing:	1 mm
Axle Height:	+3 <input checked="" type="checkbox"/> +2 <input type="checkbox"/> +1 <input type="checkbox"/> +0 <input type="checkbox"/>

Ball Stud Spacing:	0 mm
Steering Bellcrank Position:	Up <input checked="" type="checkbox"/> Down <input type="checkbox"/>
Ball Stud Spacing:	1 mm

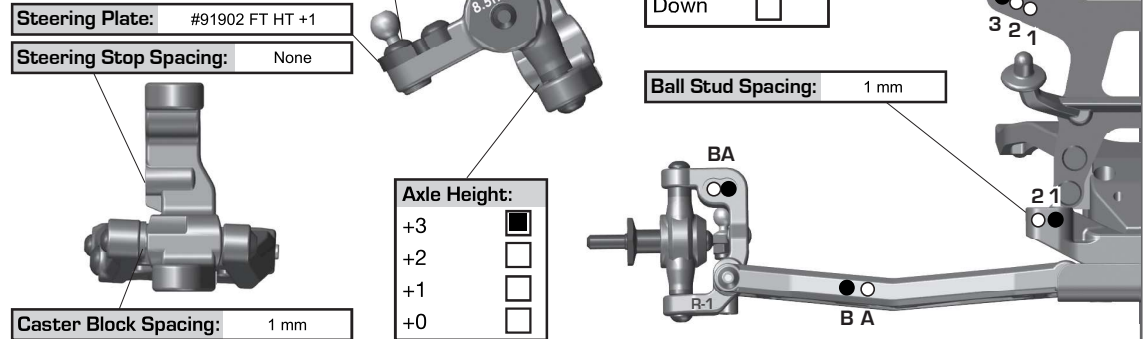

Rear Suspension:

Ride Height:	17 mm (Body Off)
Camber:	-3°
Anti-Roll Bar:	None
Arm Type:	#71141 FT Carbon
Tower Type:	Factory Foote T6.4 Buggy Shocks (No Link Mount)
Arm Spacing:	Arms Forward
Wheel Hex:	#71034 FT Clamping Hexes, 6.0 mm
Shock Mounting Position:	Front of Arm <input checked="" type="checkbox"/> Rear of Arm <input type="checkbox"/>
Hub Spacing:	Fwd <input type="checkbox"/> Mid <input checked="" type="checkbox"/> Back <input type="checkbox"/>
CVA Bone Length:	#71155 Kit, 92.5 mm
CVA Axle Type:	#92207 Kit
Notes:	#92302 FT Carbon Rear Hubs, B74.1 #91889 FT Ballstud Mount, +2 mm

C Mount:	Aluminum <input checked="" type="checkbox"/> Brass <input type="checkbox"/>
D Mount:	Aluminum <input checked="" type="checkbox"/> Brass <input type="checkbox"/>

Axle Height:	▼0 3▲ +3 ▼1 2▲ +2 ▲1 2▼ +1 ▲0 3▼ +0
--------------	--

Camber Link Spacing:	2 mm
Ball Stud Spacing:	2 mm
Ball Stud Spacing:	2 mm w/ #91889

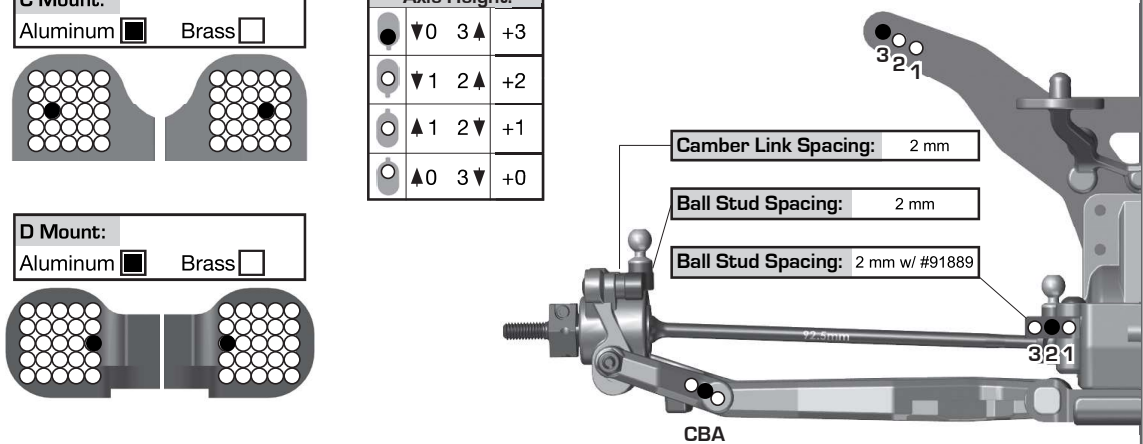

Electronics:

Radio:	Sanwa M17	Servo:	Team Powers SHT
EPA: Throttle:	100 %	Brake:	100 %
ESC:	Team Powers Radon V5BT		
ESC Settings:	See Setup Sheet		
Motor / Wind:	Team Powers V5 / 13.5T	Timing:	42°
Pinion:	#1343 FT, 25T	Spur:	#92295 78T, Octalock
Battery:	Team Powers 6800 mAh		
Battery Position:	Back 1 <input type="checkbox"/> 2 <input type="checkbox"/> 3 <input type="checkbox"/> 4 <input type="checkbox"/> 5 <input checked="" type="checkbox"/> Forward		
Battery Weight:	None		

Drivetrain:

Transmission:	Laydown: <input checked="" type="checkbox"/> Layback: <input type="checkbox"/>
Differential:	Ball Diff: <input type="checkbox"/>
Height:	+3 Gear Diff: <input checked="" type="checkbox"/>
Diff Setting:	2-Gear, #5457 FT 30K
Notes:	#91952 FT Carbon Laydown Gearbox

Slipper Clutch:

Type:	#91802 & #91806 FT Vented Plates
# of Pads:	2 x #92285 FT Octalock, 11 mm
Setting:	Tight, #91891 HD Slipper Adapter

Shocks:

	Front	Rear
Piston:	2 x 1.7 mm	2 x 1.8 mm
Thickness:	#91933 FT 2.5 mm	#91934 FT 2.5 mm
Fluid:	#5475 FT 37.5 wt	#5472 FT 30 wt
Spring:	#91945 13mm 2wd Orange	#71164 13mm Truck White
Limiters:	Int: 0 Ext: 0	Int: 0 Ext: 0
Stroke:	24.5 mm	29.0 mm
Eyelet Length:	+2	+4
Cup Offset:	0 mm	0 mm
Notes:	Rear Shocks Inverted; #91493 & #91494 FT Internals	



Track Info:

Size:	Small <input type="checkbox"/> Medium <input type="checkbox"/> Large <input checked="" type="checkbox"/> Extra Large <input type="checkbox"/>
Surface:	Dirt <input type="checkbox"/> Carpet <input type="checkbox"/> AstroTurf <input checked="" type="checkbox"/> Multi Surface <input type="checkbox"/>
Traction:	Low <input type="checkbox"/> Medium <input type="checkbox"/> High <input type="checkbox"/> Very High <input checked="" type="checkbox"/>
Moisture:	Dry <input type="checkbox"/> Damp <input checked="" type="checkbox"/> Wet <input type="checkbox"/>
Condition:	Indoor <input checked="" type="checkbox"/> Outdoor <input type="checkbox"/> Dusty <input type="checkbox"/> Hard Packed <input type="checkbox"/> Bumpy <input type="checkbox"/> Grooved <input checked="" type="checkbox"/> Smooth <input checked="" type="checkbox"/> Loamy <input type="checkbox"/>
Temperature:	Ambient: 60F Track: 60F
Notes:	

Tires:

Front Tires:	JConcepts Swagger
Front Compound:	Pink
Front Insert:	JConcepts Open Cell
Rear Tires:	JConcepts Fuzz Bite
Rear Compound:	Pink
Rear Insert:	JConcepts Open Cell
Wheel (F/R):	JConcepts Mono
Notes:	Sidewalls Glued Up To Outer Lug

Body, Weight:

Body:	JConcepts Finisher, T6.4
Body Height:	Standard
Servo Weights:	#91747 FT Steel, 24g
Electronic Weights:	#91977 FT Steel, 33g
Total Vehicle Weight:	1863g
Notes:	

Vehicle Comments: #71171 FT Carbon Side Rails, #91983 FT B6.4 Aluminum Steering Bellcranks, #91984 FT B6.4 Aluminum Steering Rack, #71156 FT T6.2 Titanium Turnbuckles, JC Titanium Top Screws