

Front Suspensions:

Camber: -1
Total Toe: +1/2
Ride Height: 28 mm (Body On)
Arm Type: #71009 Hard
Tower Type: #71005 Hard
Caster Block Insert: 5°
Kick-Up Angle: 25° Plastic
Wheel Hex: #71012 Steel Axle

Notes: #91373 Front Hinge Pin Brace, Standard
#91440 Front Caster Blocks, Standard
#91404 Steering Blocks, Standard
#91362 Top Plate, Standard
#91512 Chassis Plate, Standard
#91514 Chassis Cradle, Standard

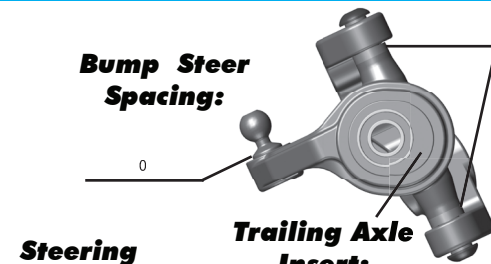

Axle Height:
Up
Middle
Down

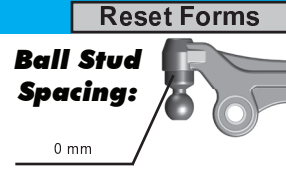

Ball Stud Spacing:
0 mm

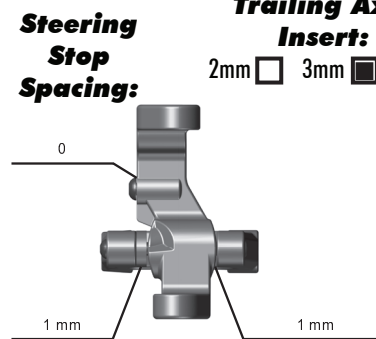

Steering Stop Spacing:
0

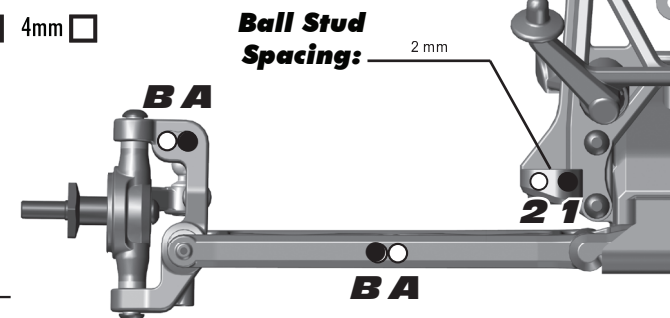

Ball Stud Spacing:
2 mm

Caster Block Spacing:
1 mm 1 mm

Rear Suspension:

Camber: -1
Ride Height: 27 mm (Body On)
Wheel Hex: #71014 Clamping 8.5 mm
Hub Spacing:
Forward Middle Back

Notes: #71011 Hard Rear Arms
#71007 Hard Rear Tower
#91548 Aluminum Rear Hubs (Back Row Inside + 2mm)

Anti Roll Bar:
None
Black (1.2mm)
Silver (1.3mm)
Gold (1.4mm)

Rear Hub Link Setting:
A C B A Up
Down
B B A Up
Down



Inboard Toe: 3
Anti-Squat: 2
Insert (D): Arrows In

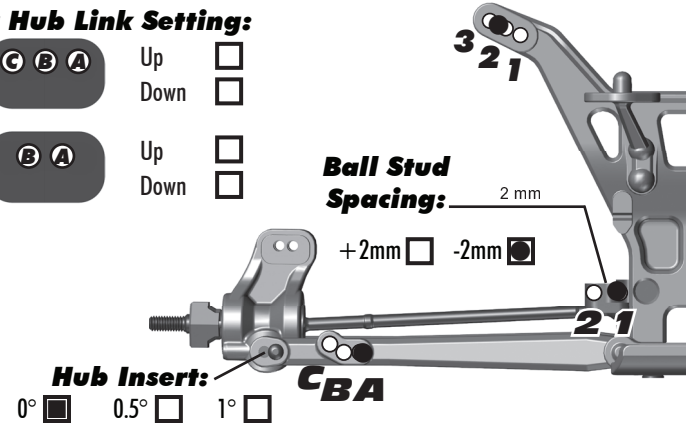

Ball Stud Spacing:
+2mm -2mm

Hub Insert:
0° 0.5° 1°

Electronics:

Radio: Airtronics M12 **Servo:** Reedy 1206
EPA: Throttle: 100 % **Brake:** 90 %
ESC: #27000 Reedy Blackbox 410R
ESC Settings: See Brent Thielke Baseline (BEC 6.0v)
Motor: Reedy Sonic M3
Wind: 7.0 **Timing:** 20°
Pinion: 19 **Spur:** 84
Battery: #602 Reedy 5300 mAh (50g Under Battery)
Battery Position: Battery Taped In - 4mm From Rear

Drivetrain:

Differential:
3 Gear: **4 Gear:**
Ball Diff: **Gear Diff:**
Notes: Tight

Slipper Clutch:

Type: #7485 Team Associated
of Pads: 2
Notes: #9739 B44 Slipper Spring

Shocks:

	Front	Rear
Piston:	2 x 1.6 Flat V2	2 x 1.7 Flat V2
Oil:	32.5 wt	32.5 wt
Spring:	Truck White	Truck Green
Limiters:	2	2
Cup Offset:	5 mm	5 mm
Stroke:	26.5 mm	34.25 mm
Free Length:	N/A	N/A
Notes:	0.030 Rear Shock Up-Travel Limiter	

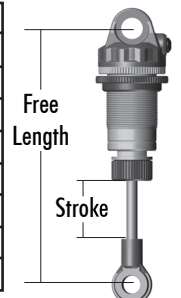

Track Info:

Size: Small Medium Large Extra Large
Surfaces: Dirt Carpet Astroturf Multi Surface
Traction: Low Medium High Very High
Moisture: Dry Damp Wet
Condition: Indoor Outdoor Dusty Hard Packed
Bumpy Grooved Smooth Loamy

Temperature: Ambient: 65F **Track:** 65F
Notes:

Tires:

Tires (F/R): JConcepts Dirt Webs / JConcepts Dirt Webs
Compound (F/R): Gold / Gold
Insert (F/R): JConcepts Dirt Tech / JConcepts Dirt Tech
Wheel (F/R): #7852 Team Associated Hex / #7852 Team Associated Hex
Notes: Sticky Kicks RC1 (Let sit for 20 minutes)

Body & Wing:

Body: JConcepts Finisher
Wing: JConcepts Finisher
Notes:

Race Results:

Qualify: 1 **Main:** A
Finish: 1 **TQ:**
Best Lap Time: 17.5

Vehicle Comments:

#91551 Factory Team Bearing Set; #91446 Factory Team Shock Bushings; #91547 Factory Team Milled Motor Plate; #91600 Factory Team Titanium Screw Kit; #91577 & #91579 Kashima Shock Bodies; #91620 & #91624 V2 Chrome Shock Shafts; #91493 X-Rings; #91450 Aluminum Shock Caps; Kit servo horn
Total Vehicle Weight: 1977g