

Front Suspensions:

Camber: -1

Total Toe: -1/4

Ride Height: 30 mm

Arm Type: #71009 Hard

Tower Type: #71004 Standard

Caster Block Insert: 5

Kick-Up Angle: 25

Wheel Hex: #71014 8.5 mm Hex & #71013 Clamping Axle

Notes: #91362 Top Plate, Standard

#91400 Caster Block, Standard

#91373 Plastic Front Hinge Pin Brace

#91392 Factory Team Aluminum Steering Set

#91512 Chassis Plate, Standard

#71002 Chassis Cradle, Standard

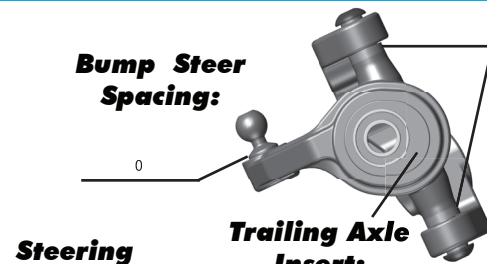

Axle Height:

Up

Middle

Down

Ball Stud Spacing:

2 mm

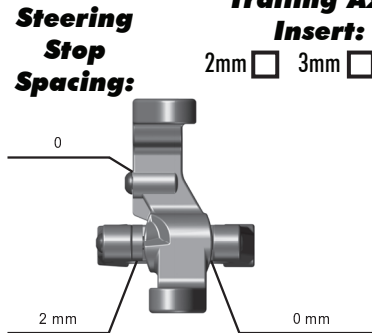

Caster Block Spacing:

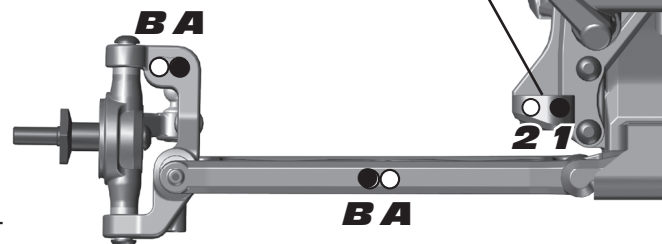

Rear Suspension:

Camber: -1

Ride Height: 28 mm

Wheel Hex: 8.5 mm

Hub Spacing:

Forward Middle Back

Notes: #71010 Rear Arms, Standard

#91549 Factory Team 0° Aluminum Hubs (Back Row Inside + 3 mm)

#91520 Factory Team Aluminum Camber Link Mount (Low + 3 mm)

#91522 & 91524 Factory Team Aluminum "C" and "D" plate

#71006 Rear Tower, Standard

Anti Roll Bar:

None

Black (1.2mm)

Silver (1.3mm)

Gold (1.4mm)

Rear Hub Link Setting:

A Up Down

B Up Down



Arm Mount:

Inboard Toe: 3

Anti-Squat: 1

Insert (D): Arrow In

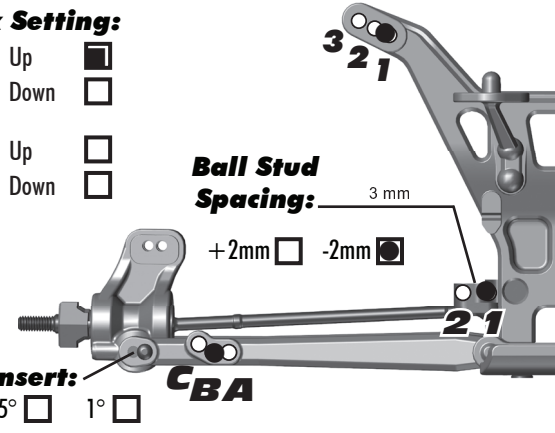

Electronics:

Radio: Airtronics M12 **Servo:** Airtronics

EPA: Throttle: 100 % **Brake:** 95 %

ESC: Team Orion R10.1

ESC Settings: Drag Brake=9, Punch=2, Brake Force=62%, Turbo=0

Motor: Team Orion VST2

Wind: 6.5 **Timing:** 2 Lines

Pinion: 19 **Spur:** 84

Battery: Team Orion Carbon 5800 mAh Saddle Pack

Battery Position: Back

Drivetrain:

Differential:

3 Gear: **4 Gear:**

Ball Diff: **Gear Diff:**

Notes: Very Tight

Slipper Clutch:

Type: Team Associated

of Pads: 2

Notes: #7495 Vented Slipper Plates

Shocks:

	Front	Rear
Piston:	2 x 1.6 Kit	2 x 1.7 Kit
Oil:	35 wt	30 wt
Spring:	Prototype White	Prototype Green
Limiters:	3	1
Cup Offset:	5 mm	5 mm
Stroke:	26.5 mm	35 mm
Free Length:	N/A	N/A
Notes:	#91493 X-Rings; #91450 Aluminum Caps	

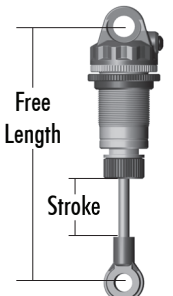

Track Info:

Size: Small Medium Large Extra Large

Surfaces: Dirt Carpet Astroturf Multi Surface

Traction: Low Medium High Very High

Moisture: Dry Damp Wet

Condition: Indoor Outdoor Dusty Hard Packed

Bumpy Grooved Smooth Loamy

Temperature: Ambient: 70° **Track:** 70°

Notes: Some slime patches to start race

Tires:

Tires (F/R): AKA Chainlinks (Slicks) / AKA Chainlinks (Slicks)

Compound (F/R): Clay / Clay

Insert (F/R): AKA / AKA

Wheel (F/R): AKA / AKA

Notes: Foam glued to the wheel; Clean tires with water only

Body & Wing:

Body: Pro-Line Kit

Wing: Pro-Line Kit

Notes: 5mm Lip

Race Results:

Qualify: 2 **Main:** A

Finish: 2 **TQ:**

Best Lap Time: 17.5

Vehicle Comments:

#91551 Factory Team Bearing Set; #91446 Factory Team Shock Bushings; #91602 Factory Team Milled Motor Plate; #91450 Factory Team Aluminum Shock Caps; #91600 Titanium Screw Kit; #91545 Graphite Battery Strap;

Total Vehicle Weight: