

### Front Suspension

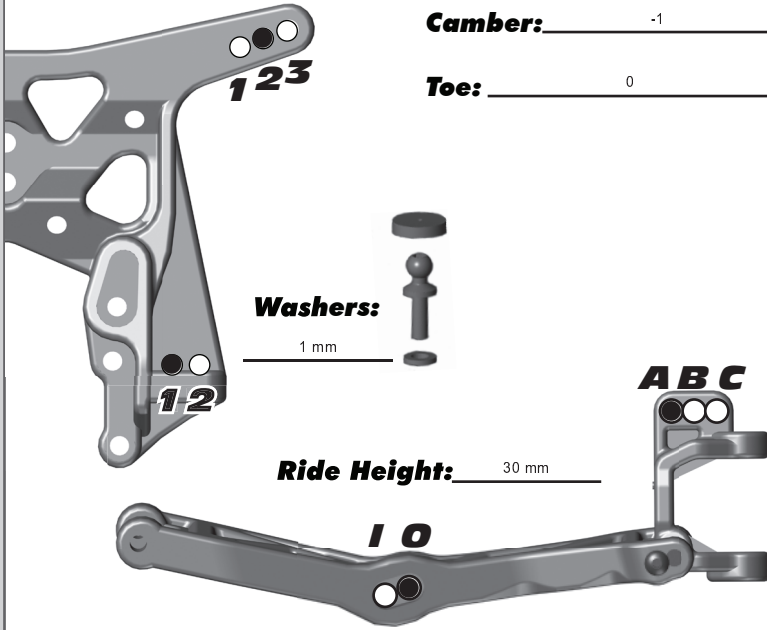

**Camber:** -1

**Toe:** 0

**Washers:** 1 mm

**Ride Height:** 30 mm

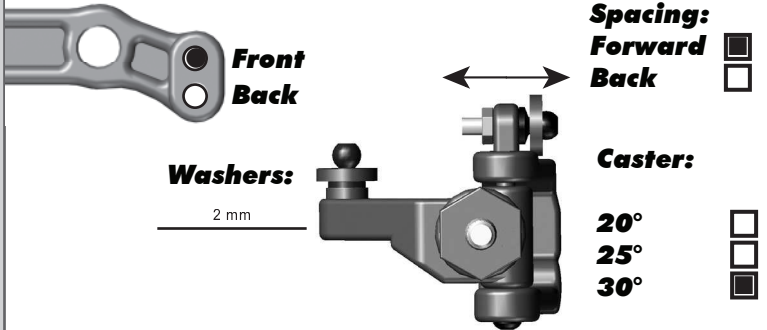
### Steering Rack:

**Front Back**
**Washers:** 2 mm

**Caster Block Spacing:**  
 Forward   
 Back 
**Caster:**  
 20°   
 25°   
 30° 

### Rear Suspension

Reset Forms

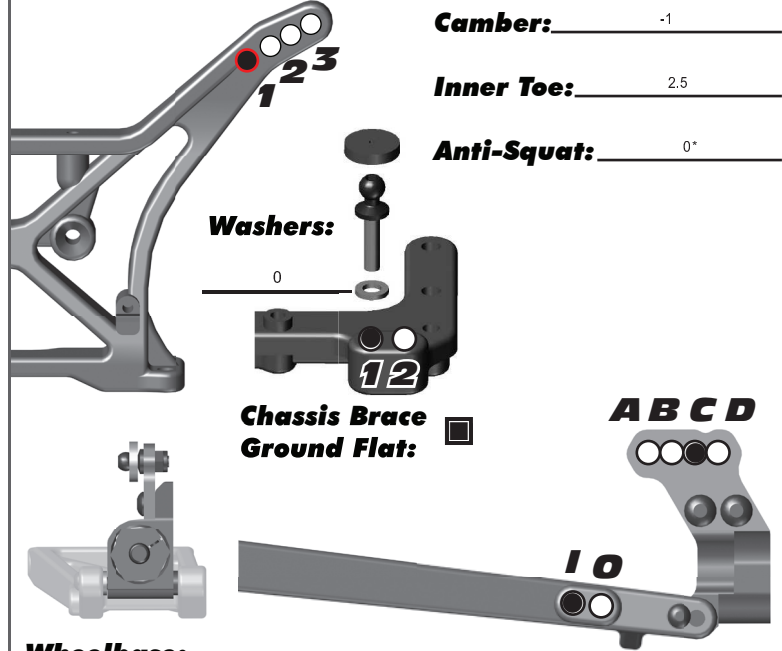
**Camber:** -1

**Inner Toe:** 2.5

**Anti-Squat:** 0°

**Washers:** 0

**Chassis Brace Ground Flat:** 
**Ride Height:** 28.5 mm

**Wheelbase:**  
 Long   
 Medium   
 Short 
**Rear Hub Carriers:**  
 0°   
 0.5°   
 1°   
 1.5° 
**Aluminum Hub Tower:**  
 A   
 B   
 C 
**Anti Roll Bar:**  
 None   
 Black (soft)   
 Silver (med)   
 Gold (hard) 

### Front Shocks

**Spring:** Associated Gray **Piston:** 2 x 1.6 Flat  
**Shock Oil:** Associated 32 wt **Limiter:** 4

### Electronics / Weight

**Motor & Wind:** Reedy Sonic Mach 2 - 7.5 Turn (20° Timing)  
**Pinion:** 19 **Spur Gear:** 84  
**Batteries:** Reedy #628 5500 mAh  
**Battery Placement:** 1 Pad Front / 2 Pads Rear  
**Ballast Weight:** Full  
**Chassis Weight:** None

### Rear Shocks

**Spring:** Associated Green **Piston:** 2 x 1.6 Flat  
**Shock Oil:** Associated 27 wt **Limiter:** 3

**Radio:** Airtronics M11x  
**Throttle / Brake e.p.a.:** 95% / 81%  
**Throttle / Brake expo:** 0% / 0%  
**Servo:** XP 1015 **Steering Expo:** 0%  
**ESC:** LRP Flow Works Team  
**ESC Settings:** v3.3 Software - 6/2/2/0/0/3

### Front Tires

**Tire:** JConcepts Barcode (Lower Case "y" Out)  
**Compound:** Green  
**Insert:** Pro-Line Closed Cell **Wheel:** Associated Hex

### Rear Tires

**Tire:** JConcepts Barcode (Capital "Y" Out)  
**Compound:** Green  
**Insert:** Pro-Line Closed Cell **Wheel:** Associated Hex

### Drivetrain

**Slipper:** VTS  
**2 Pads**  **3 Pads**  **4 Pads**   
**Notes:**

### Differentials

**Ball:**   
**Gear:**  Tight  
**Notes:**

### Other

**Body Type:** JConcepts Finisher T4.2  
**Wing Type:** Flat Full **Wing Angle:** N/A

### Race and Vehicle Comments

**Qualify:** 1 **Main:** A **Finish:** 2 **TQ:**   
**Comments:** Aluminum wing mounts; SC10 4x4 Rear Tierods

### Track Info

<b>Surface:</b>	<b>Traction:</b>	<b>Conditions:</b>	<b>Moisture:</b>
Dirt <input checked="" type="checkbox"/>	Low <input checked="" type="checkbox"/>	Grooved <input type="checkbox"/>	Wet <input type="checkbox"/>
Carpet <input type="checkbox"/>	Med <input checked="" type="checkbox"/>	Dusty <input checked="" type="checkbox"/>	Damp <input checked="" type="checkbox"/>
Astro <input type="checkbox"/>	High <input type="checkbox"/>	Smooth <input type="checkbox"/>	Dry <input checked="" type="checkbox"/>
Multi <input type="checkbox"/>		Bumpy <input checked="" type="checkbox"/>	
		Hard Pack <input type="checkbox"/>	
		Loamy <input type="checkbox"/>	