

□ **Figs. 130 & 131** Place your servo on your chassis, where shown, and take a pencil and go around the servo outlining the servo on the chassis. Now, take a piece of the #4326 servo tape, cut it off and stick it to the bottom of the servo. This stuff is very sticky, so be careful to position it right the first time. Peel off the backing. Now, very carefully position the servo directly above your pencil outline and press the servo against the chassis very firmly.

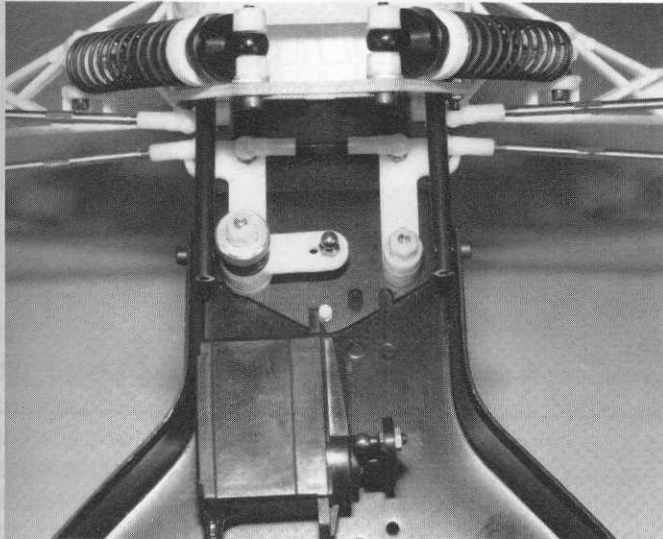

Fig. 130

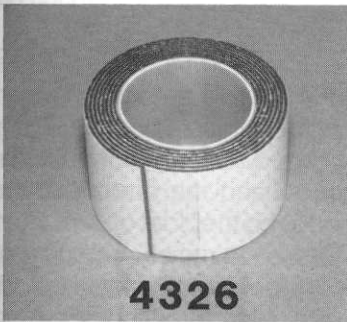

Fig. 131

4326

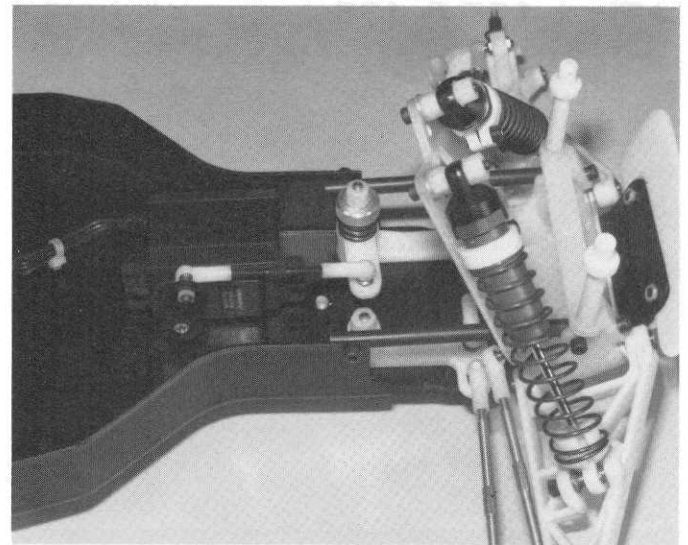

Fig. 133

□ **Figs. 132 & 133** Position the arm on the servo straight up. Center the servo saver left to right. Now measure the distance between the center of the ball on the servo arm and the center of the ball on the servo saver and make the #7552 final turnbuckle to that length. Snap on the turnbuckle.

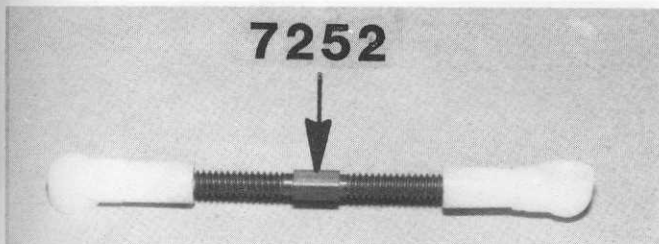

Fig. 132

□ **Fig. 134** Install the #6338 antenna mount on the chassis, where shown, with a flat head 4/40 x 1/2" screw.

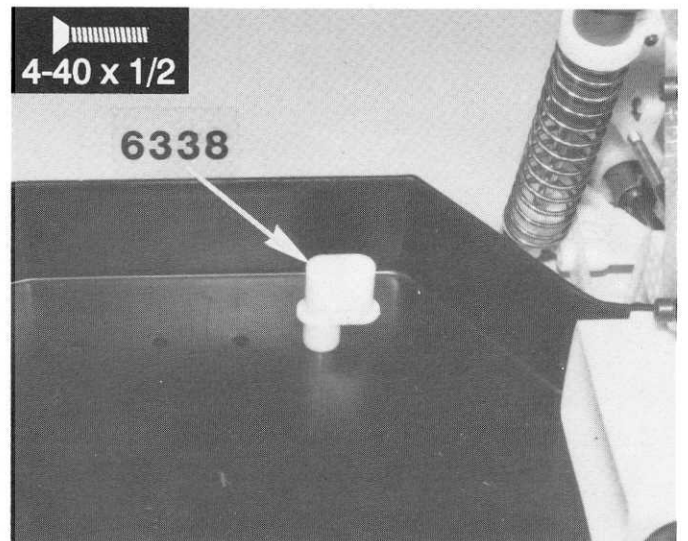

Fig. 134

❑ **Figs. 135 & 136** From Bag 7-7 take one of the #6334 battery cup out and screw the two 4/40 x 1/2" SHCS screws in, as shown. One screw will have a very small hole in the head. The screws DO NOT go all the way down. There must be enough room between the screw head and battery cup for the #6335 battery strap to mount and swing freely.

Install the strap by placing the end of the strap marked "B" over the screw head that has no hole. Slide the strap over into the groove and then slip the "A" end over the screw head with the hole in it. Slip the #6332 body clip into the hole.

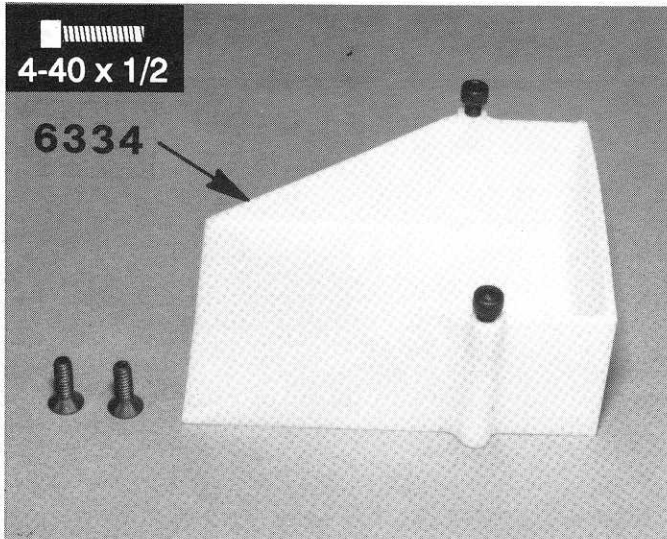

Fig. 135

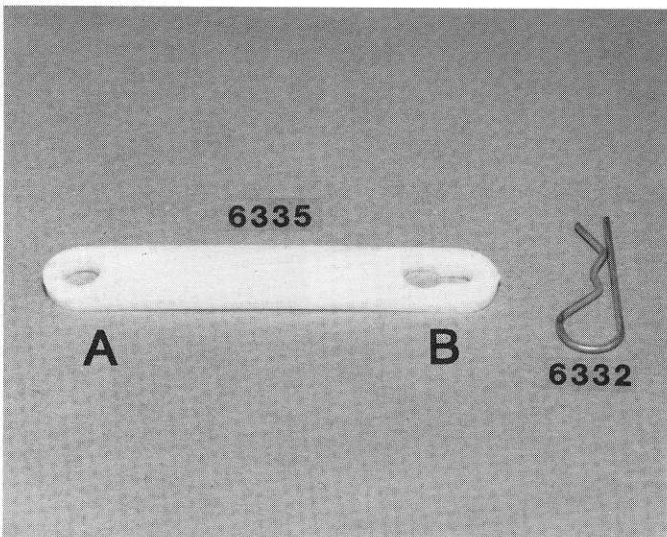

Fig. 136

❑ **Fig. 137** Install the battery cup in the chassis with two flat head 4/40 x 1/2" screws where shown.

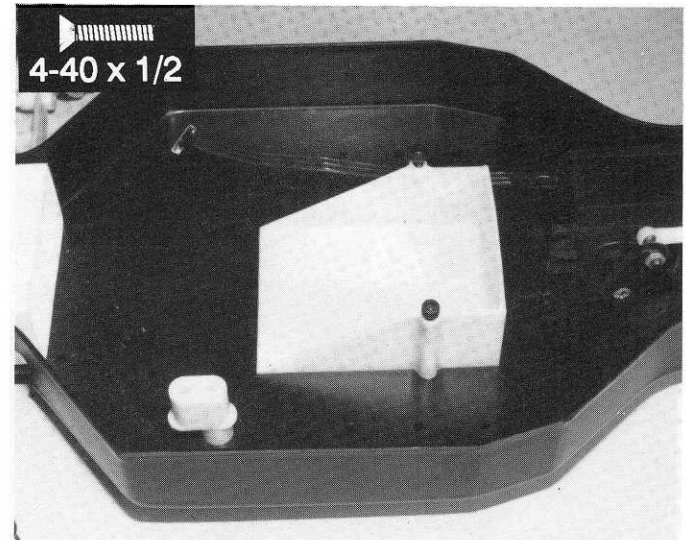

Fig. 137

❑ **Figs. 138 & 139** Time to put the horsepower in the car. This kit does not come with a motor. We highly recommend REEDY motors. You will have to pick up the motor, motor mounting screws, and the correct pinion from your local dealer. You will need to solder on the motor lead wires and filter capacitors to the motor according to the instructions included with the motor and/or speed control. Make sure that you are using ROSIN core solder to make your electrical connections. Your dealer should be able to recommend the correct pinion for the motor you decide to run. We no longer can recommend a pinion gear because of the wide range of pinion sizes used, even on stock motors, due to some of the improved performance in motors. As a starting point, the end of the pinion should be even with the end of the motor shaft.

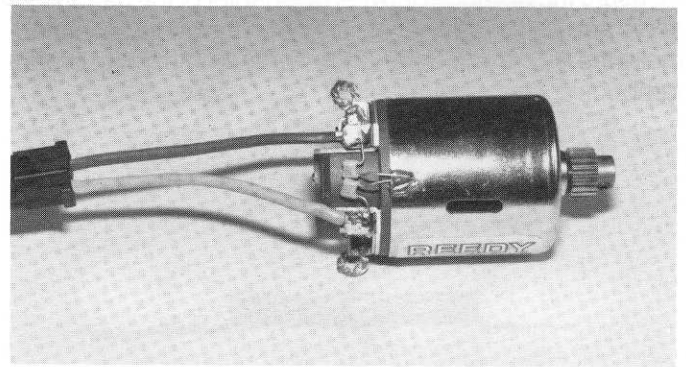

Fig. 138

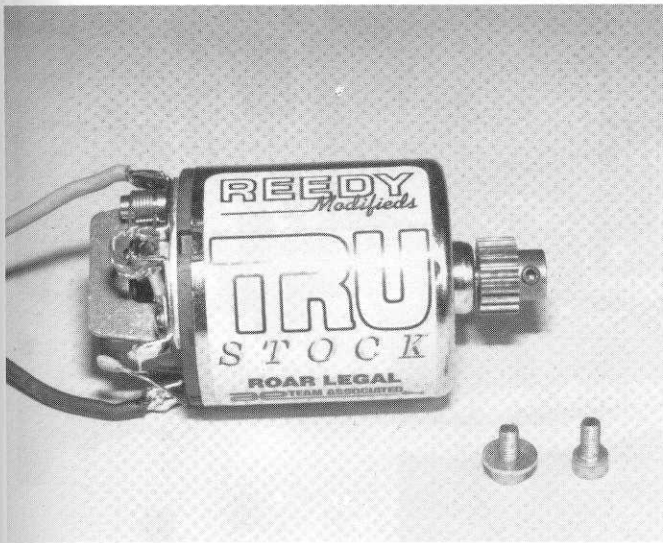

Fig. 139

□ **Figs. 140 & 141** Slip the motor in the motor mount and start the bottom screw in first. Do not tighten all the way down yet. On the top screw, put a washer on the screw and screw it in, but not tight. NOTE: Most motors are imported and use 3mm mounted screws, which are different from the rest of the fasteners in the kit. Make sure you do not mix them up.

Now we'll set the gear mesh. By moving the upper screw forward or back, we'll be moving the motor closer to or away from the plastic spur gear. What we want to do is get the metal pinion gear as close to the plastic spur gear as we can without binding up the gears. The easy way to check this is to put your finger on the plastic gear and see if you can rock it in the teeth of the metal gear. The two gears should be as close as possible, while still being able to very slightly rock the plastic gear. When you have this correct spacing, tighten down on the two motor screws and re-check the gear spacing. An incorrect gear mesh can result in a huge power loss, so do it correctly.

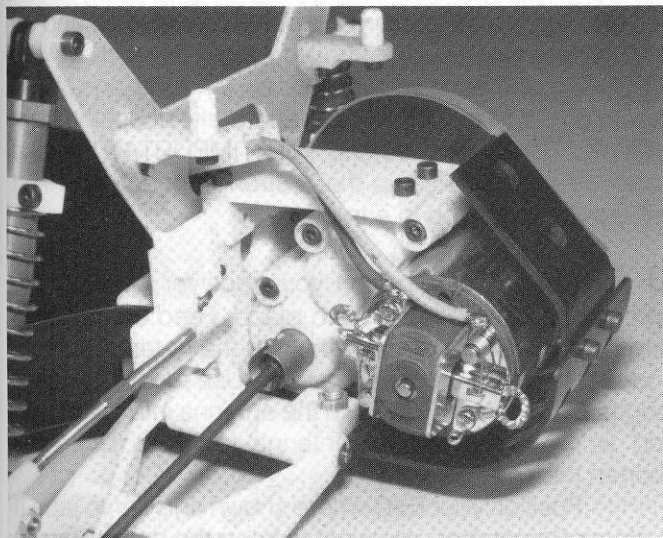

Fig. 140

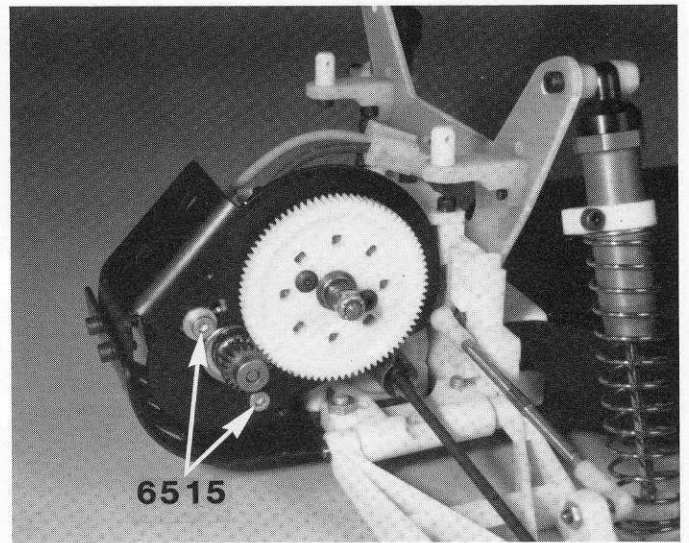

Fig. 141

□ **Figs. 142 & 143** Trim around the outside of the #6608 dust cover, cut out the center button hole and install with two 4-40 x 1/4" SHCS and washers. **CAUTION:** to remove the motor, you must first remove the dust cover. You will then have four screws out that look the same. But if you mix up the dust cover screws with the motor screws, you will strip out the threads. Keep the motor screws with the motor, and the dust cover screws with the dust cover. Also, DO NOT try to use aluminum screws to attach the dust cover, because the screws will break off when mounting the dust cover.

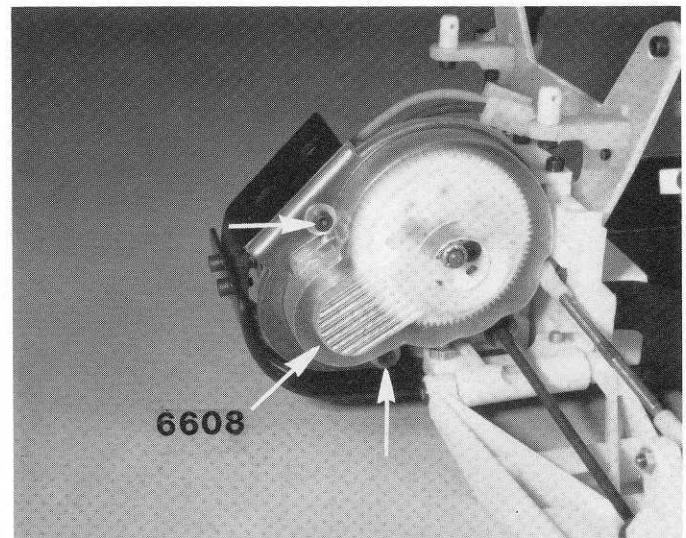

Fig. 142

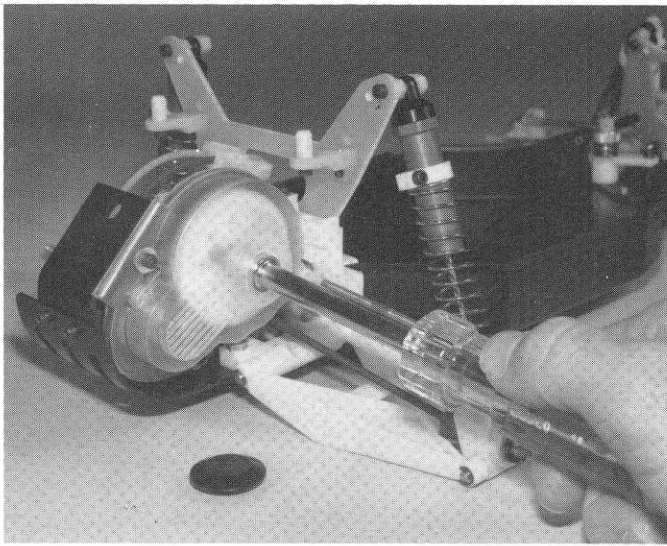

Fig. 143

Figs. 143 & 144 You will be able to make clutch adjustments easily by removing only the button. On slippery tracks, slip the clutch a little more. On high traction tracks, tighten it up a little more. You can adjust the clutch to your driving style. Make sure you always reinstall the button.

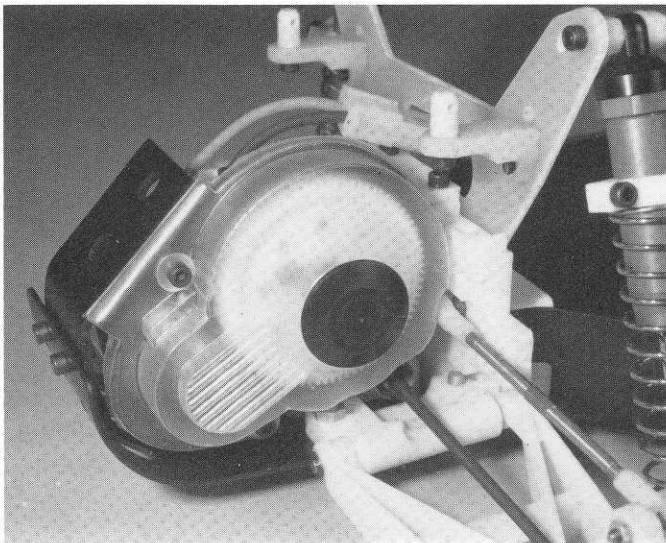

Fig. 144

RADIO INSTALLATION

Choose a good radio! FUTABA and AIRTRONICS are the most popular, but there's also some other good ones available. If you're going to race in competition, get the best radio you can afford.

Some radio systems come with one servo and an ESC (Electronic Speed Control). If your system comes with an ESC, make sure you've chosen a good one. Most racers prefer to buy their ESC separately, choosing from NOVAK, TEKIN, and others. **VERY IMPORTANT:** make sure you choose a servo that's strong enough and fast enough to do the job in a truck.

Fig. 145 Position your receiver close to the antenna and servo tape it into place. Feed the antenna wire up through the antenna hole in the antenna mount, and then through the antenna tube. Use the full antenna length. Do not shorten it. Push the antenna into the mount and tie wrap the excess antenna together. **DO NOT** shorten the antenna wire.

Position your ESC where shown and servo tape it in place. Remember, you want to keep the power (large) wires on your ESC as short as possible.

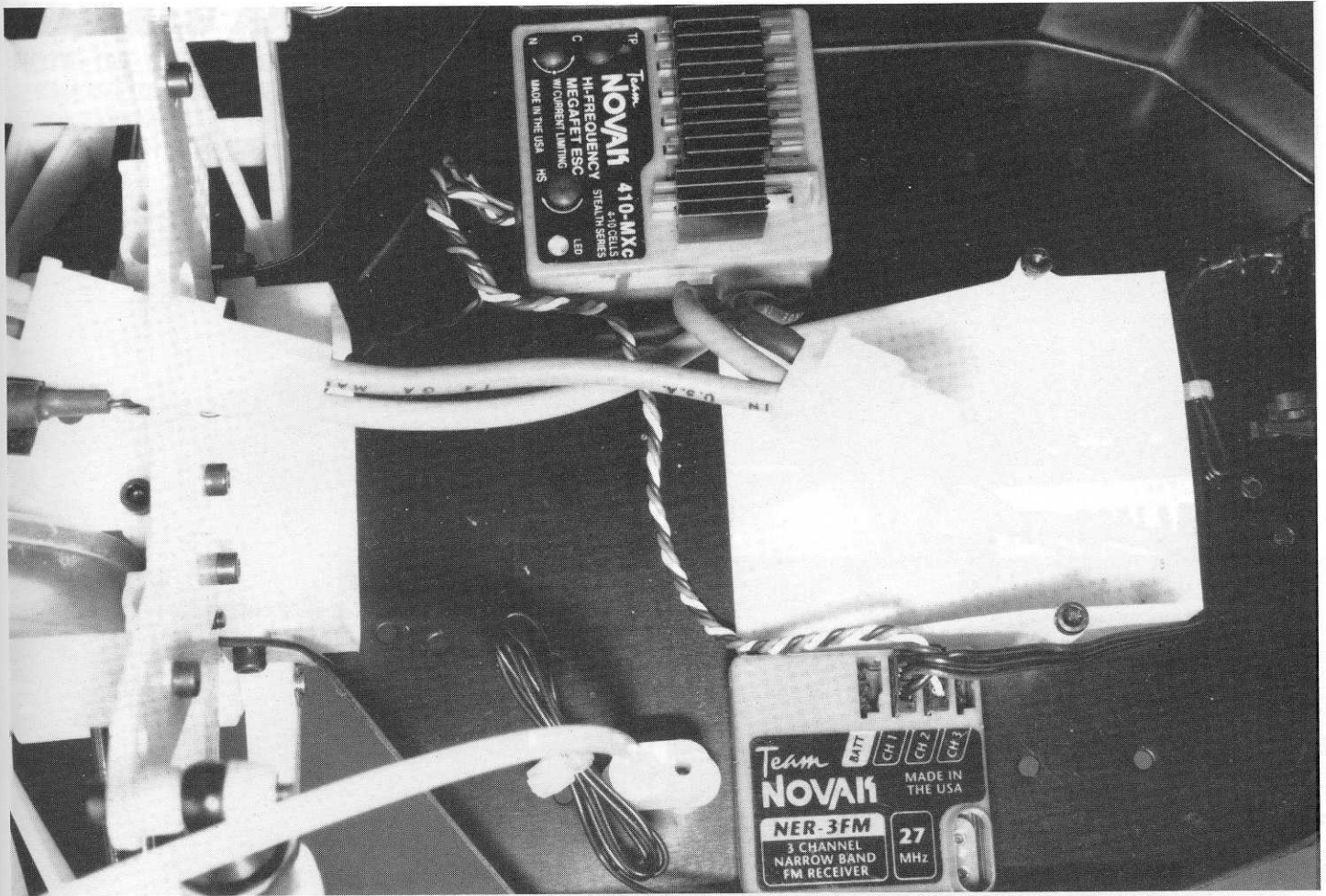

Fig. 145

□ **Fig. 146** The arrow shows a popular place to mount your ESC ON/OFF switch. It's easy to reach with the body on.

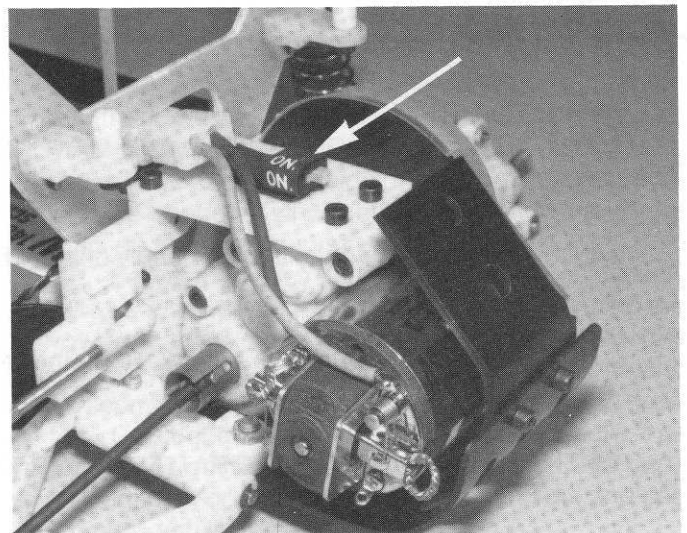

Fig. 146

Fig. 147 Your completed radio installation should look like this.

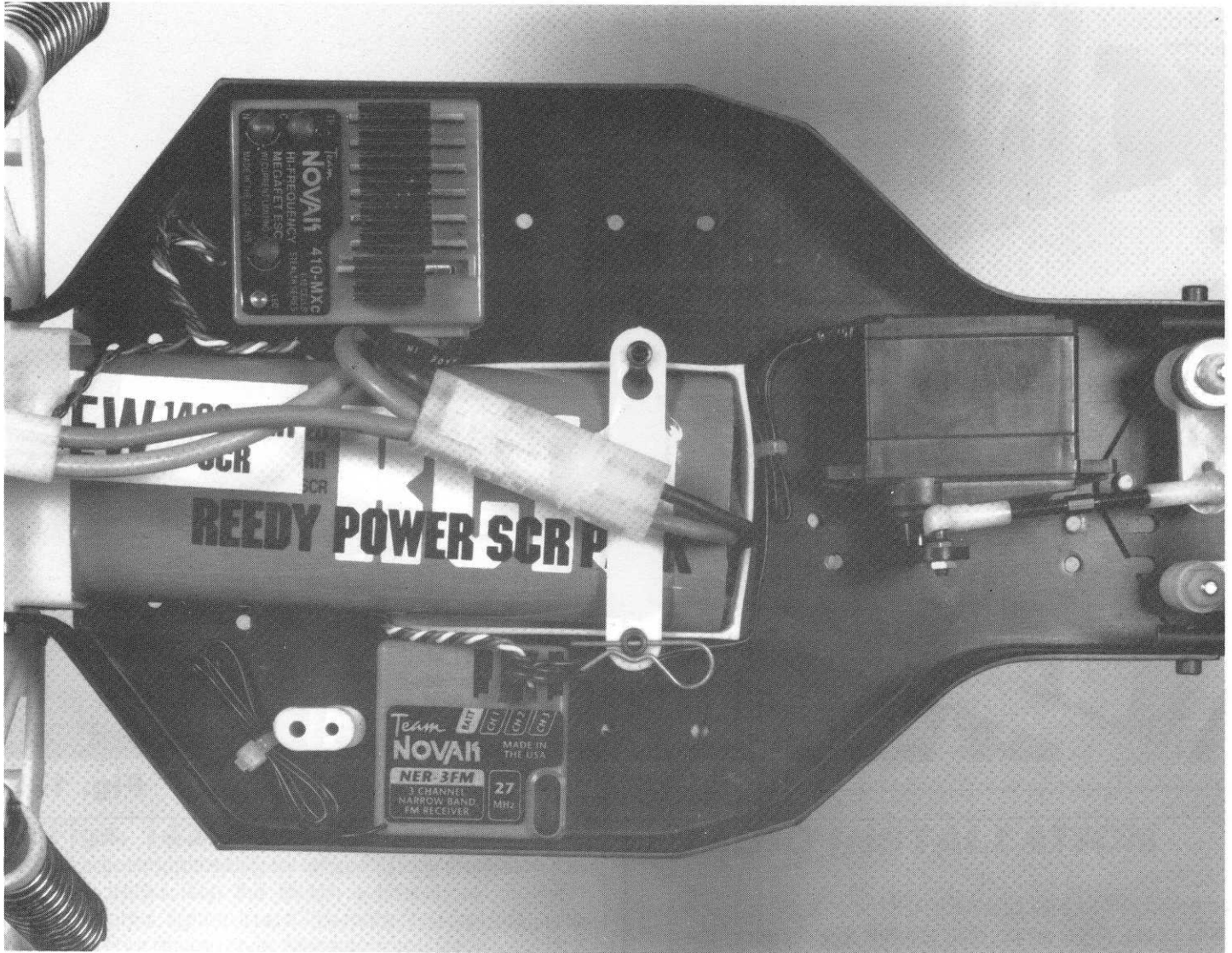

Fig. 147

- INSTALL THE RADIO PER THE RADIO MANUFACTURER'S INSTRUCTIONS.
- INSTALL THE ESC (Electronic Speed Control) PER THE ESC MANUFACTURER'S INSTRUCTIONS.
- INSTALL THE MOTOR PER THE MOTOR MANUFACTURER'S INSTRUCTIONS.
- CHARGE AND INSTALL THE BATTERIES PER THE BATTERY CHARGER MANUFACTURER'S INSTRUCTIONS.

WHEELS AND TIRES

NOTE: THE TIRES IN YOUR KIT MAY LOOK DIFFERENT FROM THE TIRES IN THE PHOTOS. WE PUT IN THE BEST TIRES FOR MOST CONDITIONS, REPLACING THEM AS TIRE DESIGN ADVANCES.

Figs. 148 & 149 Take the #7820 rear tire and insert the #7800 sleeve into the tire. Do both tires.

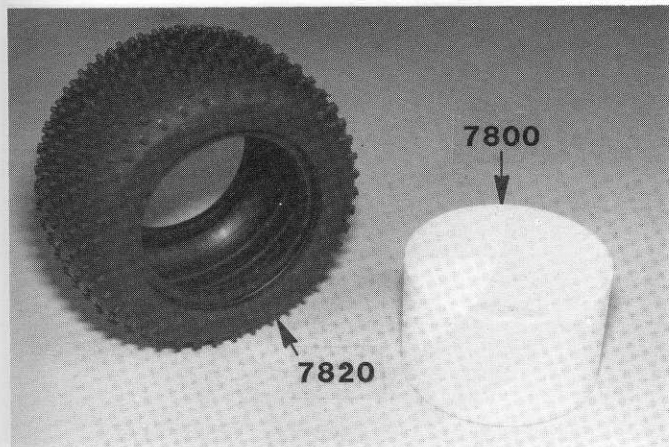

Fig. 148

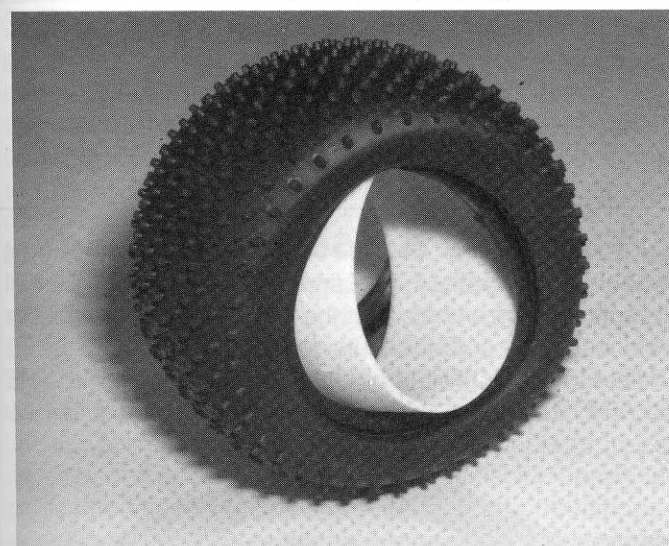

Fig. 149

Figs. 150 & 151 Make sure the sleeves are centered in the tires. The inside half of the wheel has the big hole in the center. The inside halves of the front and rear wheels are exactly the same.

Take one of the inside wheel halves with the big hole in it and one of the outside halves with the very smallest hole in it. Push the inside wheel half into the tire, seating the tire evenly. Push the outside wheel half into the tire, making sure to keep the screw holes lined up. Also, make sure the tire is seated evenly. Install the four longest 4/40 x 5/8" screws. Do not overtighten. Do the other rear wheel and tire.

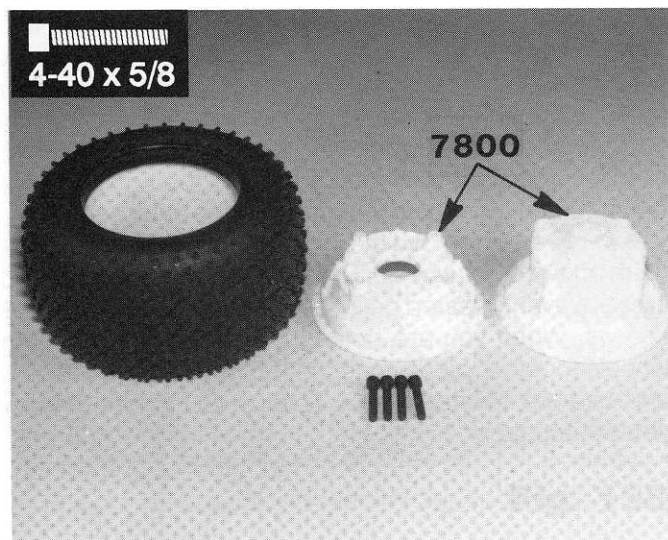

Fig. 150

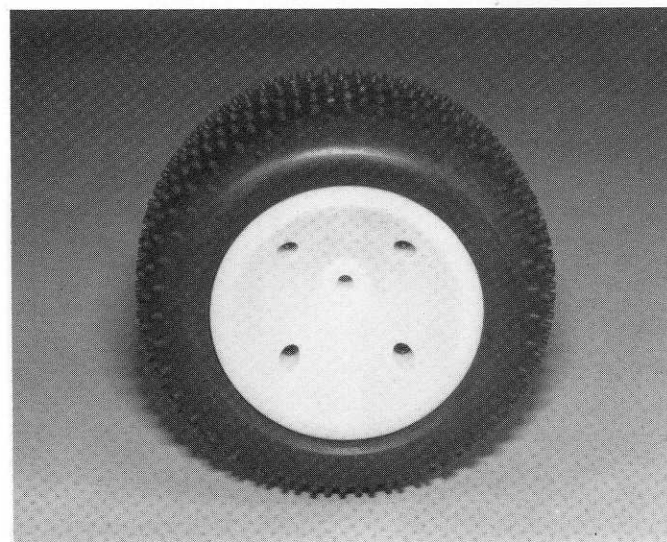

Fig. 151

Figs. 152 & 153 When we designed the RC10T truck, we looked at the ROAR rules and there was no minimum dimension listed for the front wheels and tires. Because what we were designing was similar to Stadium Trucks, we wondered why nobody was using narrow front tires, as on Stadium Trucks.

So, we made some narrow and wide front wheels and tires and did some testing. We ended up running the narrow front wheels and tires at the FLORIDA WINTER CHAMPIONSHIPS and finished 1st and 2nd. Everyone that's seen the truck wanted the narrow wheels and tires.

But, because there might be some tracks that require wide front wheels and tires, we've included parts to make narrow or wide ones. Try them both out and see which ones you like.

Put the appropriate rings in all four front tires. Next we will install the shallow outer wheel halves in the narrow front tires and the deep outer wheel halves in the wide front tires. Now you will need to decide which of the front tires you intend to run. You will then take the one set of inner front wheel halves and mount them to the tires that you have chosen. When you decide to run the other set of tires, you will need to remove the inner wheel halves and install them on the other wheels. Make sure that the wheels and tires are evenly seated before you tighten down the wheel screws. When you are bolting the wide front tires and wheels together please use the longer 4/40 x 5/8" SHCS and use the shorter 4-40 X 7/16" SHSC for the narrow wheels and tires.

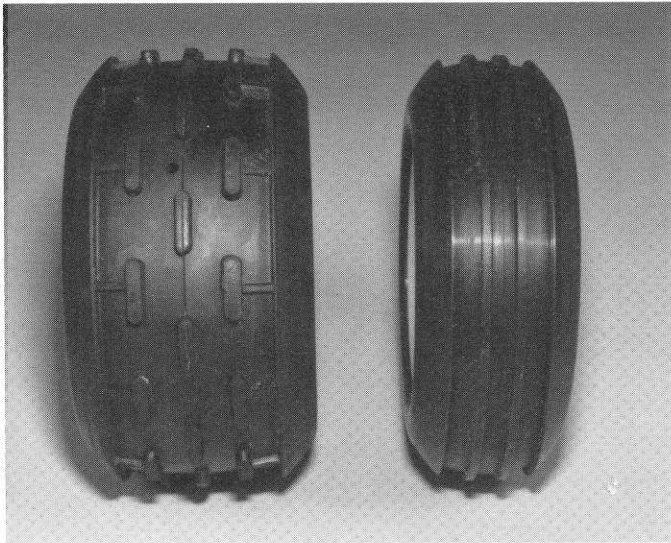

Fig. 152

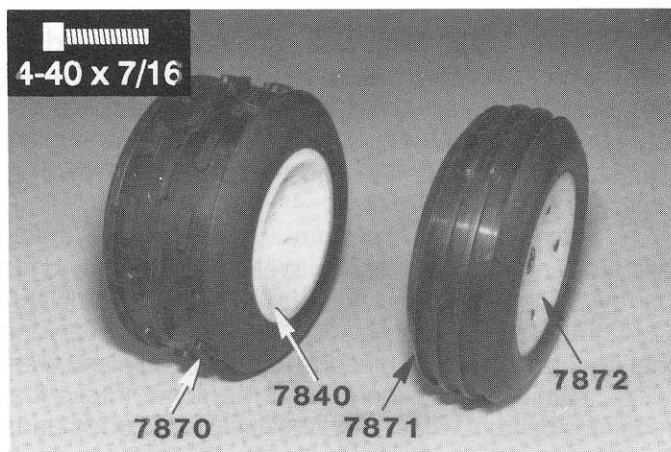

Fig. 153

Fig. 154 Install the rear wheel on the rear axle. You'll probably have to turn the wheel until you seat the groove in the back of the wheel over the split pin in the rear axle. When the wheel is correctly seated, install and tighten the 8/32" axle lock nut. Do both sides.

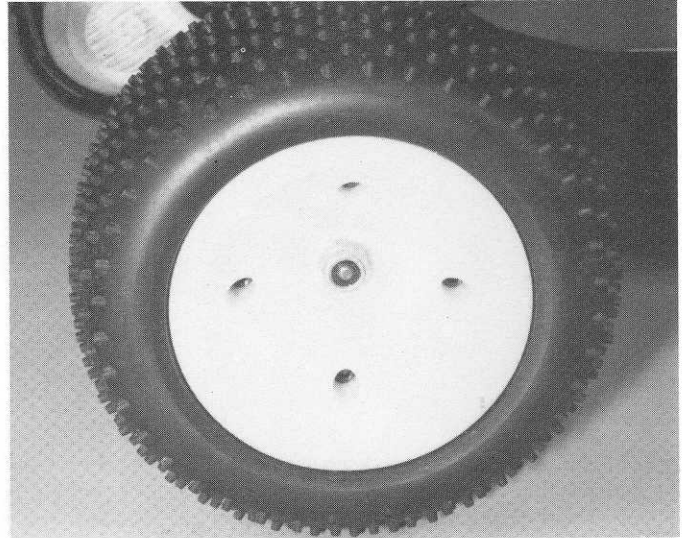

Fig. 154

Figs. 155 & 156 Pick out the pair of front wheels you're going to run, and install the four #6906 ball bearings in the wheels. Put the wheels on the front axles and install the 4-40 locknuts. **IMPORTANT: MAKE SURE THE LOCKNUTS AREN'T TOO TIGHT AND BINDING THE BEARINGS.**

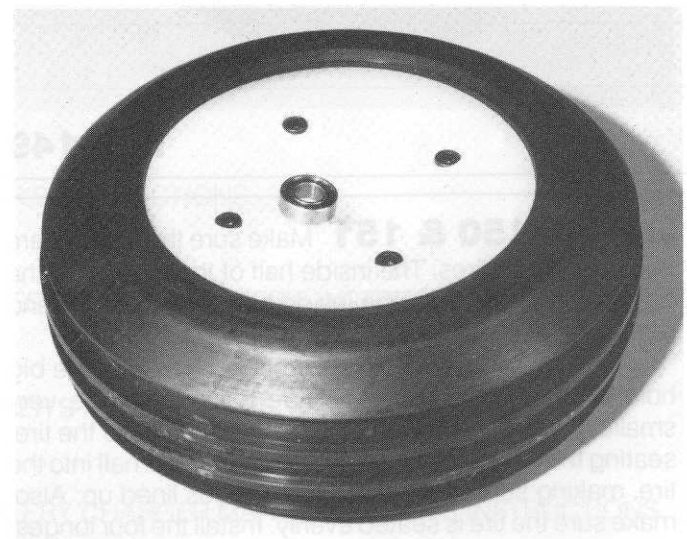

Fig. 155

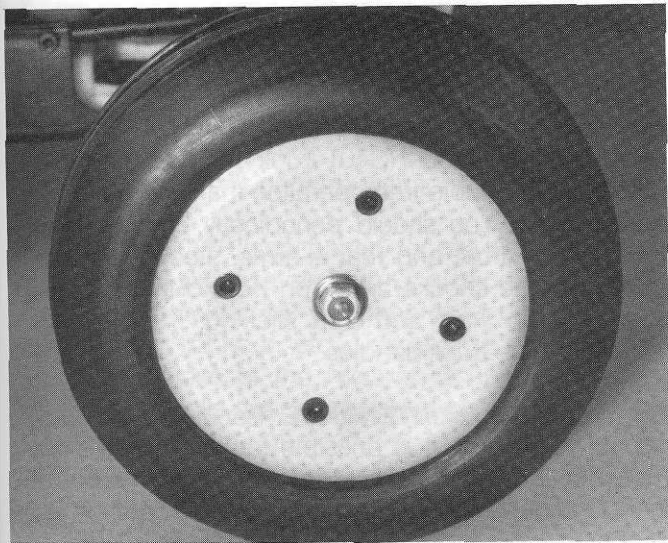

Fig. 156



Fig. 158

Figs. 157 & 158 The body can be painted before you mount it, however, it might be easier for you to mount it while it's clear because it will be easier to locate the holes for the body mounts. Fig. 159 shows the trim lines for the body. Trim a little of the body and slip it on. Keep trimming a little at a time until it clears. Cut out the body mount holes. When you've got the body fitted, it's time to paint the body.

The body is painted on the inside. There are two different ways to paint the body, by either brushing it on or spraying it on. The body is made of lexan polycarbonate. In hobby shops, you can find special Lexan or polycarbonate paints made for these type bodies to brush on. Do not use any other type brush-on paints. If you want to spray it on, one of the best type of spray paints for Lexan or polycarbonate is Pactra, available in most hobby shops.

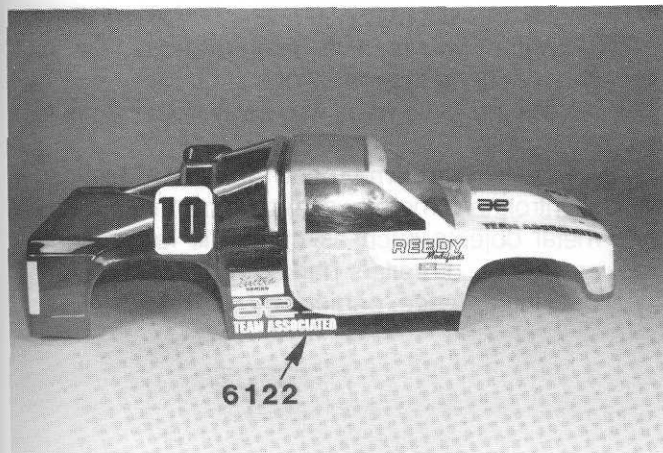

Fig. 157

Fig. 159 Apply decals to the body the way you want.

There are four large nylon washers that will fit over the top of the front and rear body posts. Use these to give the body more support. Mount the body and insert the four body clips.

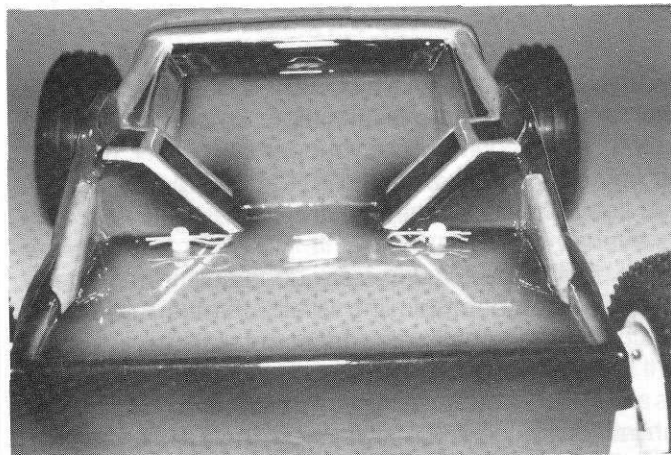

Fig. 159

Now pat yourself on the back. YOU DID FANTASTIC!
© 1991 ASSOCIATED ELECTRICS, INC.

FINAL ADJUSTMENTS

BATTERY CHARGING. Charge your transmitter batteries if they are Ni-Cds. This charge will take overnight. Charge your battery pack according to your charger manufacturer's recommendations. Make sure all the speed control connections are according to the speed control manufacturer's recommendations. Then go on to the following:

STEP 1—Turn the transmitter switch ON.

STEP 2—Make sure the motor is UNPLUGGED.

STEP 3—Plug in your car batteries.

STEP 4—Turn the car switch ON.

STEP 5—Turn the steering wheel to the right. See if the wheels turn to the right. If they turn to the left, you have a steering servo reversing switch in the transmitter that should be switched to the opposite position. Read your radio manual for more details.

STEP 6—When your wheels turn in the correct position, take your hands off the steering wheel. Is the servo arm on the steering servo centered? Refer to Fig. 129. If it's not centered, you'll have to remove the servo arm screw and center the arm.

STEP 7—Are your wheels now pointed straight forward? If not, refer to Fig. 133 and adjust the turnbuckle to correctly loosen the two linkage set collars, center the wheels, then re-tighten the collars.

STEP 8—Leave the transmitter switch ON. Turn the car switch OFF. Plug your motor into the speed control.

STEP 9— A word of caution here. You'll want to have the car sitting up on a block so the rear wheels cannot touch anything before you turn the car switch back on to set the speed control. Turn your car switch ON. Now set the speed control according to the speed control manufacturer's recommendations.

STEP 10—When you're done setting the speed control (and probably playing with the throttle) turn the car switch OFF.

STEP 11—Turn the transmitter switch OFF. The transmitter switch must always be the **FIRST SWITCH TURNED ON** and **THE LAST SWITCH TURNED OFF**.

YOUR TRUCK IS NOW READY TO RUN!

RC10T TRUCK MAINTENANCE

You'll find your RC10T truck will give you many more hours of trouble-free operation than any other car available now. You should periodically check all the moving parts: front and rear A-arms, steering blocks, steering linkage, shocks, and so on. If any of these should get any dirt in them and start sticking, it will greatly impede how the truck handles.

MOTOR MAINTENANCE. Because we're running out in the dirt, it is possible for dirt to make the brushes stick. So, if you're having motor problems, one of the first things to check is to make sure the brushes are still able to move freely in the brush holders.

If you've run enough to wear them out, Associated has replacement brushes available. A helpful product which will give you a little more power and make the brushes and commutator last much longer is Associated's Reedy-in-a-Can Power Spray #750. Simply spray a short burst of this on the brushes and commutator every time before you run and it will clean and lubricate the brushes and commutator. For those of you who want more power, Reedy Modified motors are available from Associated. Reedy Modified's #550 for stock racing and #502 for modified are good starting choices.

RADIO MAINTENANCE. A radio problem is not always caused by the radio. Often it is the result of a combination of factors which can include motor noise, poor electrical connections or layout, reversed or defective crystals, weak transmitter battery, and so on. If your radio problems persist, one or all of the following tips may help:

Make sure your motor noise capacitors are properly installed.

Make sure the brushes are free in their brush holders and are not arcing.

Try a different frequency.

Try a different motor.

Lengthen your receiver antenna and/or raise the antenna mount up to the rear shock strut.

Dress the radio wires well away from the power leads of the motor.

Note also that 75 mhz band radios and Electronic Speed Controls are more susceptible to interference. Large metal objects such as chain-link fences, light poles, cars, vans, or trailers parked near the track can cause local interference, particularly on 75 mhz.

CHARGING BATTERIES

It is important to understand the characteristics of the battery pack in your truck because how you use it will greatly affect both its performance and its life. With proper care your pack will perform well for many hundreds of cycles.

The ROAR legal battery for use with your truck is composed of six or seven "sub-C" size cells with a rated capacity of between 1.2-1.8 amperes for one hour, or 2.4 amperes for 1/2 hour, etc. This charge capacity is the same regardless of the number of cells in the pack because the cells are connected in series and the same current passes through each one.

CHARGER. A good quality charger will last longer for you than an economy unit, so please do not cut yourself short here by trying to save a couple of dollars. Any good name brand charger will do the job correctly. The more sophisticated chargers have extra features that make charging less time-consuming and can easily handle the abuse of heavy back-to-back type charging. The choice of a DC only or an AC/DC charger should be based on personal needs (where you will be using your truck, etc.) and usage.

OVERCHARGE. There is no way to make a Ni-Cd cell accept more charge than it is designed to hold. This means that as the cell approaches a fully charged condition, the portion of charging current not being stored becomes heat and pressure. If charging continues after the cell is fully charged, all of the current is converted to heat and pressure—about 40 watts worth, or the equivalent of the heat produced by an average soldering iron. High temperature and pressure is damaging to the cells, so overcharging must be avoided.

Ni-Cd cells have a built-in process for recombining the accumulated gas (actually oxygen) produced by overcharge, but the process produces heat and takes a lot of time. If you overcharge your battery and it seems to take a long time to cool down, it's because this pressure reducing reaction is taking place. Once the gas is recombined the temperature drops.

HOW TO TELL WHEN YOUR CELLS ARE CHARGED

One of the problems with Ni-Cds is their inherent voltage stability; the voltage of a fully charged cell is not much different from one that's just about dead. For that reason several indicators, along with some common sense, are needed in order to get the most out of your battery. The following is a list of indicators you can use to detect full charge.

TEMPERATURE METHOD. This works only if you start with a cool battery pack. As the pack charges, frequently check its temperature by feeling the cells directly. As soon as you notice an increase in temperature, stop charging. If the cells become too hot to hold onto, your cells are excessively overcharged. Let them cool.

TIMED CHARGE METHOD. This works only if you have confidence in the timing accuracy of your charger. Many chargers on the market only approximate a constant charging current; they may vary from six amps when you first start charging, all the way down to two amps if the Ni-Cd pack is nearly charged and the voltage of the charging source (automobile battery) is low. If the charging current varies, it becomes difficult to estimate the average current. However, if your charger is reasonably dependable, you can use the following method.

Charge your pack using the "temperature method" above and keep track of the time required to reach full charge. Once you have established the time, you can use it as a setting for the timer on your charger. To be safe, use a setting about a minute less than what you established. This method allows you to charge without constantly monitoring the battery temperature.

If you charge a battery that is still hot from running, reduce the time about 20%. Then, after the pack has cooled, finish charging with the temperature method.

VOLTAGE METHOD. Voltage is a poor indication of a cell's state of charge. In fact, other factors like temperature, current drain, and "cell memory" have as much of an effect on voltage as the state of charge does. However, if current flow and temperature are held constant, it is possible to see the cell voltage gradually climb during the charging process. The absolute value of this voltage isn't of much use—how the voltage changes is an excellent indicator. To use this method, you will need a digital voltmeter or an expanded-scale voltmeter capable of resolving 0.01 volts on the 10 volt range.

Connect the voltmeter across the Ni-Cd pack, preferably right at the cell terminals, or, if that's not possible, across the terminals of the throttle control

resistor. Don't try to read the voltage at the output of the charger because you'll end up reading the voltage drop through all the connectors and cables between the charger and the Ni-Cd pack, which can sometimes distort the effect you're looking for. You should start with a Ni-Cd pack that is less than half charged. Connect your charger and begin charging at four amps. If your charger is adjustable, set the current now—but don't try to change it later. A constant current charger is preferable here, but if yours gradually drops off during charge, that's still permissible, as long as it doesn't drop below three amps.

Watch the voltage as the pack charges. Notice that the voltage at first climbs rapidly and in the middle of the charging cycle more slowly. This voltage will most likely be in the range of 8 1/2 to 9 volts for a six cell pack. As the pack approaches full charge, the voltage will begin to climb more rapidly; and as it goes into overcharge, the climb will slow down and then stop. This is where you stop charging—at the point where the voltage stops climbing. If you left the charger on, the voltage would begin to fall as the pack went deeply into overcharge and started to heat up. The maximum voltage reached will probably be in the nine to ten volt region; the actual value is unimportant.

When measuring voltage on NiCad cells, you must use a digital VOM (volt/ohm meter). A conventional analog scale VOM is not sensitive enough. By the time you see the needle move across the scale, you would have already damaged the battery cells.

SLOW CHARGE METHOD. Slow or "overnight" charging is a method you are not likely to use often, but it is a good way to bring the pack to absolutely full charge. However, the output voltage of a slow charged pack is slightly lower.

The charging current must be between 0.05 and 0.12 amperes. If less current, the pack will never reach full charge; any more and the pack will overheat. The time required to reach full charge ranges from 15 to 40 hours, depending on the current used. The charger can be left on for a much longer time without harming the cells; however, the output voltage of the pack will be temporarily lowered by an extremely long overcharge. The voltage returns to normal after a discharge-charge cycle.

These next two tips are really for the benefit of serious racers. If you're just out having fun, don't worry about them.

FULL DISCHARGE. Ni-Cd packs perform best if they are COMPLETELY discharged before they are charged. If you are involved in racing, you will have to do this if you expect to win any races! Discharge for at least an hour (preferably overnight with a clip-on resistor) before charging.

Associated Chargers have a discharge function. Various clip-on discharge resistors (about 30 ohms, 10 watts) are available at hobby stores.

TOPPING-UP can give you a little extra voltage at the beginning of a race, as long as you don't overdo it. Put the last minute or two of charge into your pack just before the race starts.

GOOD LUCK IN YOUR RACING!

CAUTION

Ni-cad batteries are susceptible to damage when overcharged at a high rate, and can release caustic chemicals if the overcharge is severe.

Do not stall the motor under power. If the truck stops suddenly on the track, or fails to move forward when you attempt to accelerate, push the throttle control on your transmitter to the brake position immediately and attend to the truck. A small rock can stall the gears, and if the throttle is left in the on position the result can be a burned out motor (or electronic speed control unit).

If you run your truck to the point where more than one cell in the pack is completely discharged, it is possible to lose radio control of the truck before the drive motor stops completely. For this reason you should not operate your truck in an area where it could be harmed or cause harm, such as near a busy roadway or a pool of water. Usually radio control will be regained as soon as you pick up the truck and the motor is allowed to free-run. If you still don't have control, then you should unplug the motor.

When you stop running your truck, turn off the radio at the truck first before turning off the transmitter.

A burned-out or shorted motor can make the truck appear to have radio problems. If the truck slows down suddenly and the radio acts erratically even with a full battery charge, then the cause is probably the motor. Check the range of the radio with the motor unplugged. A shorted motor will draw extremely high current even under no-load conditions.

SAVE THIS BOOKLET!

MORE THAN AN INSTRUCTION MANUAL, IT'S ALSO A HANDY, PICTORIAL SUPPLEMENT TO TEAM ASSOCIATED'S RC10T CATALOG.

REFER TO THIS MANUAL FOR PART NUMBER AND NAME WHEN ORDERING.