

Front Suspension:

Reset Forms

Ride Height:	26 mm
Camber:	-1°
Toe:	0° (Tierod Gap = 42.9 mm)
Arm Type:	#71104 Flat, Hard
Tower Type:	#71115 Flat
Caster Block Insert:	5°
Steering Block:	4 mm
Bulkhead Type:	#91656 Plastic
Kick-Up Angle:	25°
Wheel Hex:	8.5 mm (Kit)
Notes:	#1366 FT Aluminum Servo Horn, 25T #91667 Plastic Steering Rack #91668 Aluminum Steering Bellcranks

Anti Roll Bar:

White (1.2mm)

Gray (1.3mm)

Blue (1.4mm)

Other:

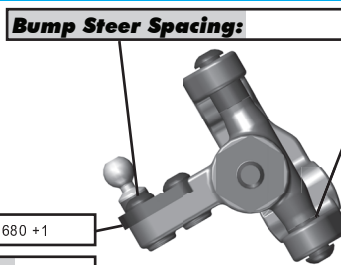

Axle Height:

+3

+2

+1

0

Ball Stud Spacing: 2 mm

Steering Plate: #91680 +1

Steering Stop Spacing: 0

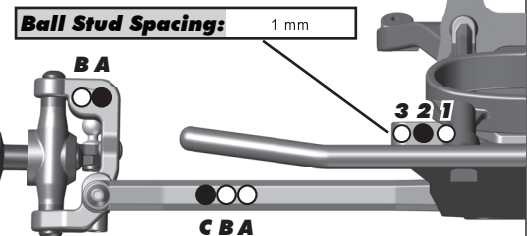
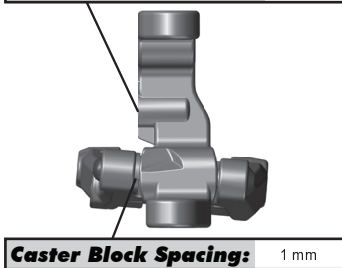

Rear Suspension:

Ride Height:	25 mm
Camber:	-1°
Arm Type:	#71105 Standard
Tower Type:	#71116 Standard (Doubled Up)
Wheel Hex:	#91610 FT 7.0 mm
Hub Spacing:	Forward <input type="checkbox"/> Middle <input checked="" type="checkbox"/> Back <input type="checkbox"/>
Shock Mounting Position:	Front of Arm <input type="checkbox"/> Rear of Arm <input checked="" type="checkbox"/>
Notes:	

Anti Roll Bar:

White (1.1mm)

Gray (1.2mm)

Blue (1.3mm)

Other:

Rear Hub Link Setting:

Plastic Hub Aluminum Hub Ball Stud Spacing: 3 mm

Up:

Down:

C Mount Inserts: 1° 0.5°

Aluminum Brass

D Mount Inserts: 1° 0.5°

Aluminum Brass

Hub Insert:

+3 +2 +1 0

Ball Stud Spacing: 3 mm

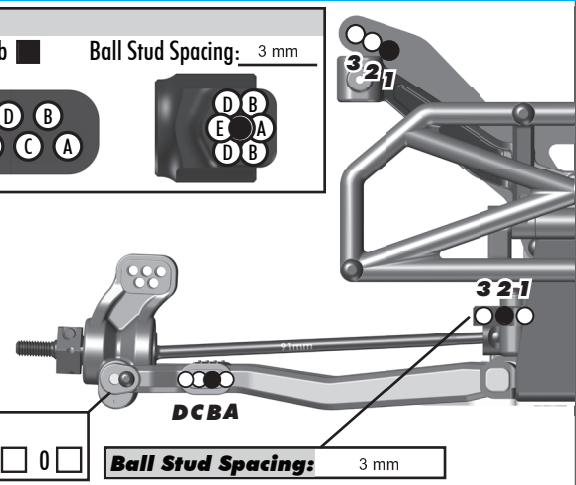

Electronics:

Radio: Futaba T7PX	Servo: SavoxSC-1258TG
EPA: Throttle: 100 %	Brake: 92 %
ESC: Hobbywing	
ESC Settings: N/A	
Motor: Hobbywing	
Wind: 6.5	Timing: 30°
Pinion: #1336 FT 18T	Spur: 81
Battery: Protek 5800	
Battery Position: 5F	

Drivetrains:

Transmission: Laydown:

3 Gear: Layback:

4 Gear: Stand Up:

Differential: Ball Diff:

Height: 2 Gear Diff:

Notes: 15k - 4 Gear

Slipper Clutches:

Type: #91802 & #91806 Team Associated Vented Plates

of Pads: 2 x #91197 LCF

Shocks:

	Front	Rear
Piston:	2 x 1.6 Flat Machined	2 x 1.7 Flat Machined
Fluid:	#5433 FT 37.5 wt	#5432 FT 32.5 wt
Spring:	#91638 Truck Blue	#91640 Truck White
Limiters:	0	0
Stroke:	28.0 mm	35.0 mm
Eyelet Length:	Long	Short
Cup Offset:	5 mm	5 mm
Notes:	#91494 Machined Shock Spacers; #91493 FT X-Rings	

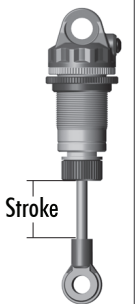

Track Info:

Size: Small Medium Large Extra Large

Surface: Dirt Carpet Astroturf Multi Surface

Traction: Low Medium High Very High

Moisture: Dry Damp Wet

Condition: Indoor Outdoor Dusty Hard Packed

Bumpy Grooved Smooth Loamy

Temperature: Ambient: 75F Track: 75F

Notes:

Tires:

Front Tires: JConcepts Dirt Webs

Front Compound: Silver

Front Insert: JConcepts Closed Cell

Rear Tires: JConcepts Dirt Webs

Rear Compound: Silver

Rear Insert: JConcepts Closed Cell

Wheel (F/R): JConcepts Hazard

Notes:

Body, Wing, Weight:

Body: JConcepts Hi-Flow Lightweight

Body Height: Front #2 / Rear #3

Servo Weights: 30g Between Servo & Receiver

None Aluminum Steel Other

Electronic Weights: Aluminum + Steel Weight

None Aluminum Steel Other

Total Vehicle Weight: 2164g

Vehicle Comments:

Notes: #91577 & #91579 Fox Shock Bodies; #91620 & 91624 Chrome Shock Shafts;