

Front Suspension:

Reset Forms

Ride Height:	26 mm
Camber:	-1°
Toe:	0°
Arm Type:	#71104 Flat, Hard
Tower Type:	#71115 Flat
Caster Block Insert:	0°
Steering Block:	4 mm
Bulkhead Type:	#91656 Plastic
Kick-Up Angle:	25°
Wheel Hex:	8.5 mm (Kit)
Notes:	#1366 FT Aluminum Servo Horn, 25T #91667 Plastic Steering Rack #91668 Aluminum Steering Bellcranks

Anti Roll Bar:

White (1.2mm)

Gray (1.3mm)

Blue (1.4mm)

Other:

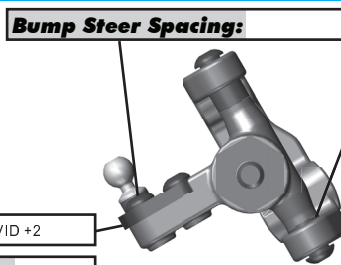

Axle Height:

+3

+2

+1

0

Ball Stud Spacing: 1 mm

Steering Plate: AVID +2

Steering Stop Spacing: 0

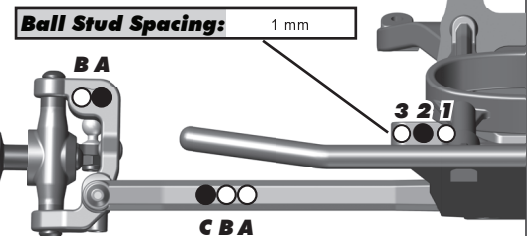
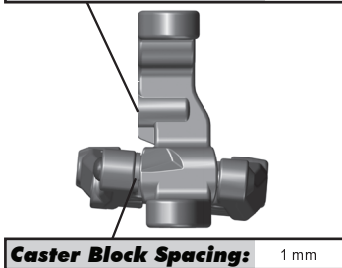

Rear Suspension:

Ride Height:	25 mm
Camber:	-1°
Arm Type:	#71105 Standard
Tower Type:	#71116 Standard
Wheel Hex:	#91610 FT 7.0 mm
Hub Spacing:	Forward <input type="checkbox"/> Middle <input checked="" type="checkbox"/> Back <input type="checkbox"/>
Shock Mounting Position:	Front of Arm <input checked="" type="checkbox"/> Rear of Arm <input type="checkbox"/>
Notes:	

Anti Roll Bar:

White (1.1mm)

Gray (1.2mm)

Blue (1.3mm)

Other:

Rear Hub Link Setting:

Plastic Hub Aluminum Hub Ball Stud Spacing: 3 mm

Up Down

C Mount Inserts: 1° 0.5°

Aluminum Brass

D Mount Inserts: 1° 0.5°

Aluminum Brass

Hub Insert:

+3 +2 +1 0

Ball Stud Spacing: 3 mm

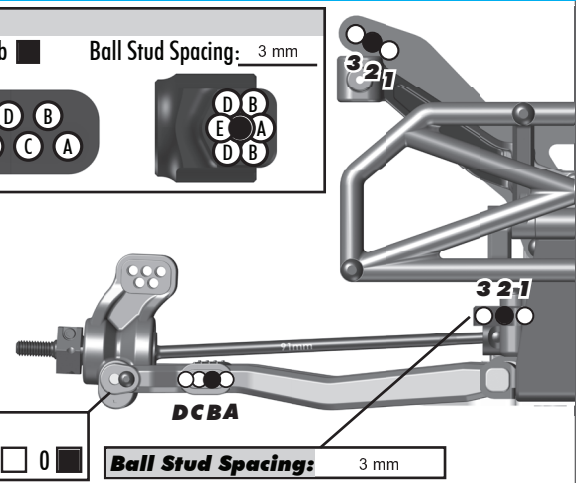

Electronics:

Radio: Futaba T7PX	Servo: SavoxSC-1258TG
EPA: Throttle: 100 %	Brake: 92 %
ESC: Hobbywing	
ESC Settings: N/A	
Motor: Hobbywing	
Wind: 6.5	Timing: 30°
Pinion: #1336 FT 18T	Spur: 81
Battery: Protek 5800 (#27304 Reedy 36+36+22g Under Battery)	
Battery Position: 4F	

Drivetrains:

Transmission:	Laydown: <input type="checkbox"/>
3 Gear: <input checked="" type="checkbox"/>	Layback: <input checked="" type="checkbox"/>
4 Gear: <input type="checkbox"/>	Stand Up: <input type="checkbox"/>
Differential:	Ball Diff: <input checked="" type="checkbox"/>
Height: 3	Gear Diff: <input type="checkbox"/>
Notes:	
Slipper Clutch:	
Type: #91802 & #91805 Vented B6.1 Slipper Hubs	
# of Pads: 2 x #91197 LCF	

Shocks:

	Front	Rear
Piston:	2 x 1.6 Flat Machined	2 x 1.7 Flat Machined
Fluid:	32.5 wt	30 wt
Spring:	Gray	White
Limiters:	0	0
Stroke:	28 mm	35 mm
Eyelet Length:	Long	Short
Cup Offset:	5 mm	5 mm
Notes:	#91494 Machined Shock Spacers	

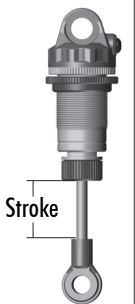

Track Info:

Size: Small <input type="checkbox"/> Medium <input type="checkbox"/> Large <input type="checkbox"/> Extra Large <input checked="" type="checkbox"/>
Surface: Dirt <input checked="" type="checkbox"/> Carpet <input type="checkbox"/> Astroturf <input type="checkbox"/> Multi Surface <input type="checkbox"/>
Traction: Low <input type="checkbox"/> Medium <input type="checkbox"/> High <input checked="" type="checkbox"/> Very High <input type="checkbox"/>
Moisture: Dry <input checked="" type="checkbox"/> Damp <input type="checkbox"/> Wet <input type="checkbox"/>
Condition: Indoor <input checked="" type="checkbox"/> Outdoor <input type="checkbox"/> Dusty <input type="checkbox"/> Hard Packed <input checked="" type="checkbox"/> Bumpy <input type="checkbox"/> Grooved <input type="checkbox"/> Smooth <input type="checkbox"/> Loamy <input type="checkbox"/>
Temperature: Ambient: 45F Track: 40F
Notes:

Tires:

Front Tires: JConcepts Dirt Webs
Front Compound: Gold
Front Insert: JConcepts Closed Cell
Rear Tires: JConcepts Dirt Webs
Rear Compound: Gold
Rear Insert: JConcepts Closed Cell
Wheel (F/R): JConcepts Hazard
Notes: FDJ Green

Body, Wing, Weight:

Body: JConcepts Hi-Flow Lightweight
Body Height: Front #2 / Rear #3
Servo Weights: None <input checked="" type="checkbox"/> Aluminum <input type="checkbox"/> Steel <input type="checkbox"/> Other <input type="checkbox"/>
Electronic Weights: None <input type="checkbox"/> Aluminum <input checked="" type="checkbox"/> Steel <input type="checkbox"/> Other <input type="checkbox"/>
Total Vehicle Weight: 2117g

Vehicle Comments:

Notes: #91577 & #91579 Fox Shock Bodies; #91620 & 91624 Chrome Shock Shafts;