

Front Suspensions:

Camber: -2

Total Toe: +1/2

Ride Height: 30 mm

Arm Type: Hard #71009

Tower Type: Hard #71005

Caster Block Insert: 5

Kick-Up Angle: 25 Plastic

Wheel Hex: Clamping 6.0 mm #71034

Notes: Top Plate, Standard #91362

Chassis Plate, Standard #91512

Caster Blocks, Standard #91400

Steering Blocks, Standard #91404

Steering Set, Plastic #91391

Factory Team Aluminum Servo Horn, #1366

JConcepts Titanium Front Axle

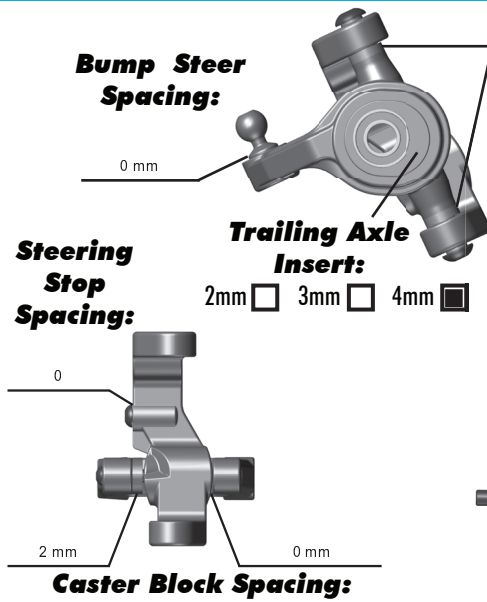

Axle Height:

Up

Middle

Down

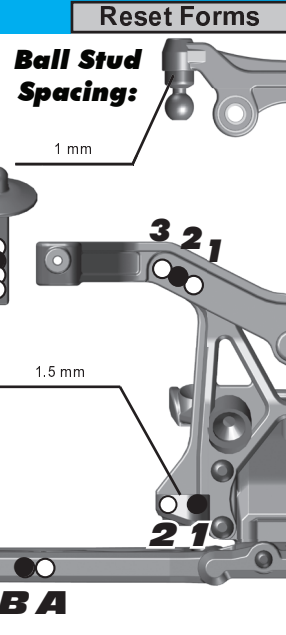

Rear Suspension:

Camber: 0

Ride Height: 28 mm

Wheel Hex: 8.5 mm

Hub Spacing:

Forward Middle Back

Notes: Rear Arms, Hard #71011 (Spaced Back)

Factory Team Aluminum Hubs #91549 (Back Row Inside +3mm)

Brass "C" Plate #91523

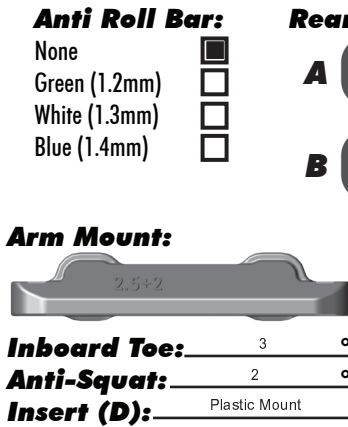

Rear Hub Link Setting:

A C A Up Down

B B A Up Down

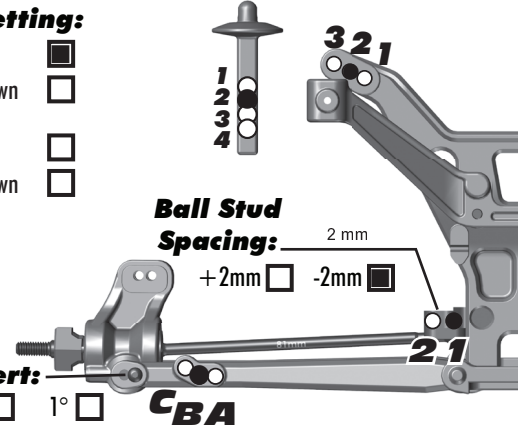

Electronics:

Radio: Sanwa M12S **Servo:** Savox 1258TG

EPA Throttle: 100 % **Brake:** 100 %

ESC: Team Orion

ESC Settings: N/A

Motor: Team Orion VST2 Lightweight

Wind: 7.5 **Timing:** 0

Pinion: #1337 Aluminum 19 **Spur:** 84

Battery: Team Orion 4500 Shorty (50g under battery all the way back)

Battery Position: 6 mm From Rear (Battery Taped In)

Drivetrain:

Differential:

3 Gear: **4 Gear:**

Ball Diff: **Gear Diff:**

Notes: Tight

Slipper Clutch:

Type: Team Associated VTS

of Pads: 3

Notes: B44 Slipper Spring #9739

Shocks:

	Front	Rear
Piston:	2 x 1.5 Flat V2	2 x 1.6 Flat V2
Oil:	37.5 wt	30 wt
Spring:	AE Truck Gray	AE Truck White
Limiters:	3	1
Cup Offset:	5 mm	5 mm
Stroke:	26.25 mm	37.25 mm
Free Length:	N/A	N/A
Notes:	Kashima Shock Bodies, Chrome V2 Shafts, X-Rings	

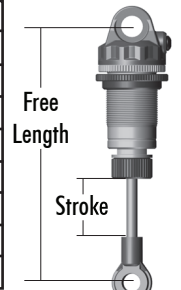

Track Info:

Size: Small Medium Large Extra Large

Surfaces: Dirt Carpet Astroturf Multi Surface

Traction: Low Medium High Very High

Moisture: Dry Damp Wet

Condition: Indoor Outdoor Dusty Hard Packed Bumpy Grooved Smooth Loamy

Temperature: Ambient: 80F Track: 80F

Notes:

Tires:

Tires (F/R): AKA Typos / AKA Chain Links

Compound (F/R): Clay / Clay

Insert (F/R): AKA Black / AKA Black

Wheel (F/R): JConcepts Hazard +3mm / JConcepts Hazard +3mm

Notes: Sticky Situation (Spec Tire Additive)

Body & Wing:

Body: JConcepts High Flow

Wing: All Side Fins

Notes: Lightweight

Race Results:

Qualify: 1 **Main:** 1

Finish: 1 **TQ:**

Best Lap Time:

Vehicle Comments:

Factory Team Bearing Set #91553; Plastic Shock Caps #91449; Shock Bushings, Aluminum #91446; Lunsford titanium screw kit; Chassis plate rib removed behind servo; UpGrade chassis skin

Total Vehicle Weight: 2150g