

:: Driver: _____ **:: Date:** _____
:: Track: _____
:: Event: _____

Setup Sheet for Team Associated's 10R5 OVAL

Rev. 1

:: Front Suspension

Kingpin Lube: _____ Springs: LF: _____ RF: _____

Upper Arm Mounts: LF: 0° 5° 10°
 RF: 0° 5° 10°

Camber: LF: _____ RF: _____

Ride Height: _____

Mounting Plate Riser:

Yes No

Kingpin:
 shim qty/thickness,
 LF: _____ RF: _____

shim qty/thickness,
 LF: _____ RF: _____

Wheel axle shims:
 LF: _____ RF: _____

Lower arm
 spacing: LF: _____ RF: _____

Caster:

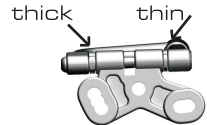

LF: 1.80°
 RF: 1.80°

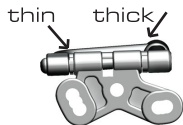

3.25°
 3.25°



6.15°
 6.15°

Front ride height
 spacers:
 LF: _____ RF: _____

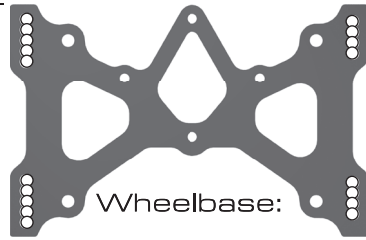

Wheelbase:

:: Rear Suspension

T-Plate: _____ 2 screws 3 screws

Ride Height Adjuster: _____

Ride Height: _____

Side Shocks

Oil: LR: _____ RR: _____

Spring: LR: _____ RR: _____

Center Shock

Piston: _____

Oil: _____

Spring: _____

Position:

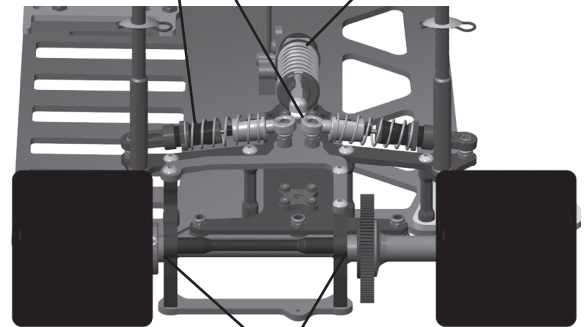

Hub spacers: LR: _____ / RR: _____

Notes: _____

:: Tires

Tires	LEFT	RIGHT
Tire Compounds	F	
	R	
Tire Diameter	F	
	R	
Tire Width	F	
	R	

Tire Treatment Type: _____

Total Car Weight: _____ oz.

Tweak Settings

_____ oz. _____ oz.

(front)

(rear)

_____ oz. _____ oz.

Shade in amount
 of tire treatment

:: Battery Placement

Front

Rear



Shade in battery placement for
 Sub C-cells / LiPo battery pack.
 Battery: _____

:: Track Info / Body

smooth: bumpy:

traction: high med. low

Body Type and Make: _____

Body Height: _____

Wing: _____

Notes: _____

:: Motor/Speed Control

Motor: _____

Timing: _____ Gear: _____ / _____

E.S.C. : _____

E.S.C. Settings: _____

:: Transmitter

Turning Circle: _____

Steering Expo: _____

Brake E.P. : _____

Throttle Expo: _____

Notes: _____