

### Front Suspension:

Reset Forms

Ride Height:	18mm
Camber:	-2°
Toe:	0
Anti-Roll Bar:	None
Arm Type:	#92411 FT Carbon
Tower Type:	#92430 Kit
Wheel Hex:	#91607 FT Clamping, 5.0mm
Steering Block KPI:	#91985 B6.4-1 Scrub, Carbon, 3mm Trail
Caster Block Insert:	0 <input type="checkbox"/> +2.5 <input type="checkbox"/> +5 <input checked="" type="checkbox"/>
Bulkhead Type:	#92436 FT 0°, Aluminum
Kick-Up Angle:	-2.5 <input type="checkbox"/> 0 <input checked="" type="checkbox"/> +2.5 <input type="checkbox"/>
Steering Stop Spacing:	1.5mm / 3.5 Turns Out
Caster Block Spacing:	Fwd <input checked="" type="checkbox"/> Back <input type="checkbox"/>
Notes:	#71181 FT Hex Adapter Front Axles, Titanium #91983 FT Steering Bellcranks, Aluminum

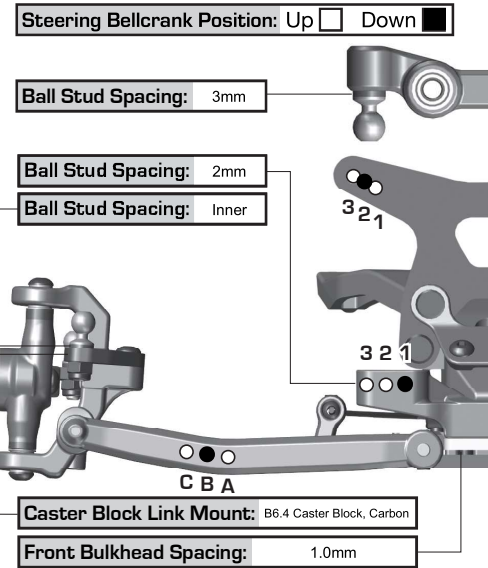
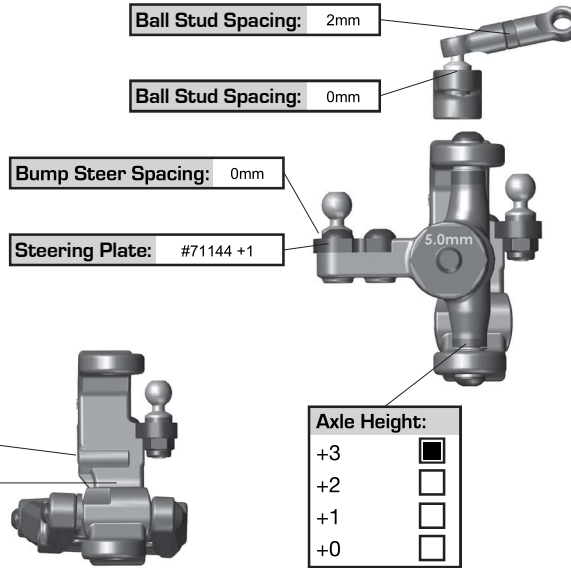

### Rear Suspension:

Ride Height:	17mm
Camber:	-0.5°
Anti-Roll Bar:	None
Arm Type:	#92409 FT Carbon
Tower Type:	#92483 FT Carbon, -2mm
Arm Spacing:	Fwd <input type="checkbox"/> Mid <input checked="" type="checkbox"/> Back <input type="checkbox"/>
Wheel Hex:	#71034 FT Clamping, 6.0mm
Hub Type:	Std <input type="checkbox"/> HRC <input checked="" type="checkbox"/> #92412 Standard
Hub Spacing:	Fwd <input type="checkbox"/> Mid <input type="checkbox"/> Back <input checked="" type="checkbox"/>
Drive Shaft:	CVA's <input checked="" type="checkbox"/> Universals <input type="checkbox"/>
Notes:	#92477 FT Ballstud Mount, +2mm

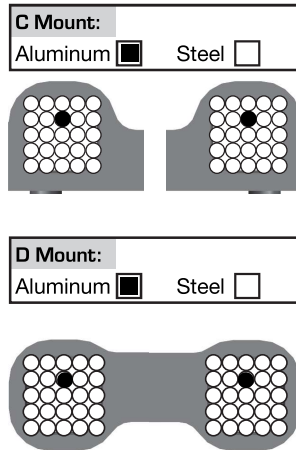

Axle Height:	
▼0 3▲	+3
▼1 2▲	+2
▲1 2▼	+1
▲0 3▼	+0

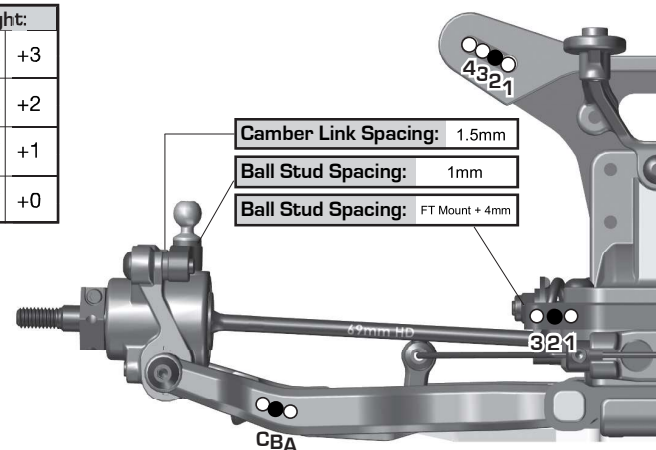

### Electronics:

Radio:	Futaba 10TPX	Servo:	#27115 Reedy RT2007A
EPA: Throttle:	100 %	Brake:	94 %
ESC:	#27017 Reedy Blackbox 610R		
ESC Settings:	See Setup Sheet		
Motor / Wind:	#27490 Reedy Sonic M4 7.5T	Timing:	20°
Pinion:	#1339 FT 22T	Spur:	#92295 Octalock 78T
Battery Mount:	Std <input checked="" type="checkbox"/> Offset <input type="checkbox"/>		
Battery:	See Notes	Weight:	#27355 Reedy Battery Weight, 20g
Notes:	#27604 Reedy Zapper SG6 4800 LP		

### Drivetrain:

Differential:	Ball Diff: <input checked="" type="checkbox"/>		
Height:	2	Gear Diff:	<input type="checkbox"/>
Diff Setting:	#91918 FT Diff Decoder = 205		
Notes:			

### Slipper Clutch:

Type:	Kit Plates & Spring
# of Pads:	#92288 Octalock 19mm White x 2
Setting:	Front Tires Lift 5mm
Notes:	

### Shocks:

	Front	Rear
Piston:	2 x 1.6 + 1 x 1.5	1 x 1.6 + 2 x 1.7mm
Thickness:	#91932 2.5mm	#91933 2.5mm
Fluid:	#5471 FT 27.5wt	#5471 FT 27.5wt
Spring:	1Up Yellow	1Up White
Limiters:	Int: 0mm Ext: 0mm	Int: 0mm Ext: 0mm
Stroke:	23.2mm	28.2mm
Eyelet:	+2mm	+0mm
Cup Offset:	0 <input type="checkbox"/> +5 <input checked="" type="checkbox"/> +9 <input type="checkbox"/>	0 <input type="checkbox"/> +5 <input type="checkbox"/> +9 <input type="checkbox"/>
Kashima Bodies:	<input checked="" type="checkbox"/>	Chrome Shafts: <input checked="" type="checkbox"/> Machined Spacers: <input checked="" type="checkbox"/>
Notes:	#91986 FT Fox Shock Upgrade Kit	

### Track Info:

Size:	60' x 110'
Surface:	Hard Packed
Traction:	Medium-High
Moisture:	Very Low
Condition:	Grooved w/ Dust On Edges
Temperature:	65F
Notes:	

### Tires:

Front Tires:	JConcept 2wd Smoothie2
Front Compound:	Silver
Front Insert:	JConcepts Dirt Tech (Glued To Wheel)
Rear Tires:	JConcepts Smoothie2
Rear Compound:	Silver
Rear Insert:	JConcepts Dirt Tech
Wheel (F/R):	#9690 & #9695 Team Associated 12mm Hex
Notes:	Clean w/ Sprayway; Papa Willy's Purple

### Body, Weight:

Body:	#92422 Team Associated B7
Front Wing:	JConcepts Upper Front Wing
Rear Wing:	#92424 Team Associated B7 Kit
Wing Angle:	0° <input type="checkbox"/> 3° <input type="checkbox"/> 6° <input checked="" type="checkbox"/>
Chassis Length:	#92490 RC10B7 -4mm
Servo Weights:	#92446 FT Carbon
Electronic Weights:	#91975 FT Carbon
Total Vehicle Weight:	1533g

### Vehicle Comments:

Notes:	#92360 FT Titanium Turnbuckle Set
	#92480 FT One-Piece Servo Mount, Black
	#92475 FT Motor Mount, Blue
	Kit Transmission Case, Side Rails, Top Plate & Front Camber Link
	Schelle Titanium Screws
	Steering Curve = -15; Steering Speed = 90/90
	Response = Steering 5 / Throttle 5