



Driver: Billy Hayden Event: Winter Testing Qualify: N/A Main: N/A  
 Date: Winter 2024 Tracks: SDRC Raceway Finish: N/A Best Lap Time: N/A

### Front Suspension:

Reset Forms

Ride Height: 19mm  
 Camber: -1°  
 Toe: 0° (Tierod Gap = 27.7mm)  
 Anti-Roll Bar: None  
 Arm Type: #92411 FT Carbon  
 Tower Type: #92430 Kit  
 Wheel Hex: #91682 Kit  
 Steering Block KPI: #92415 FT Carbon - 4 Trail / KPI 3  
 Caster Block Insert: 0  -2.5  -5   
 Bulkhead Type: #92436 FT 0°, Aluminum  
 Kick-Up Angle: -2.5  0  +2.5   
 Steering Stop Spacing: 0mm  
 Caster Block Spacing: Fwd  Back   
 Notes: #91983 FT Steering Bellcranks, Aluminum

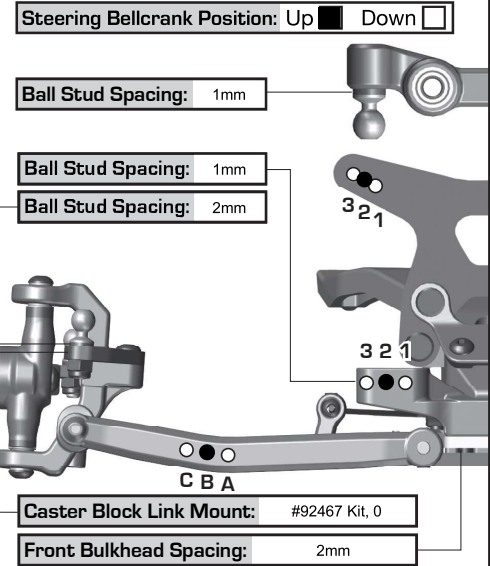
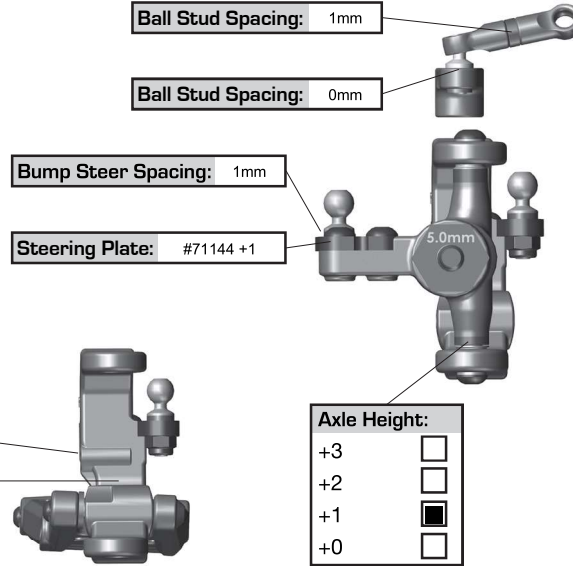

### Rear Suspension:

Ride Height: 19mm  
 Camber: -1°  
 Anti-Roll Bar: None  
 Arm Type: #92409 FT Carbon  
 Tower Type: #92431 Kit  
 Arm Spacing: Fwd  Mid  Back   
 Wheel Hex: #91609 FT Clamping, 5.0mm  
 Hub Type: Std  HRC  #92413 FT Carbon  
 Hub Spacing: Fwd  Mid  Back   
 Drive Shaft: CVA's  Universals   
 Notes: #92185 FT Carbon Hub Link Shims

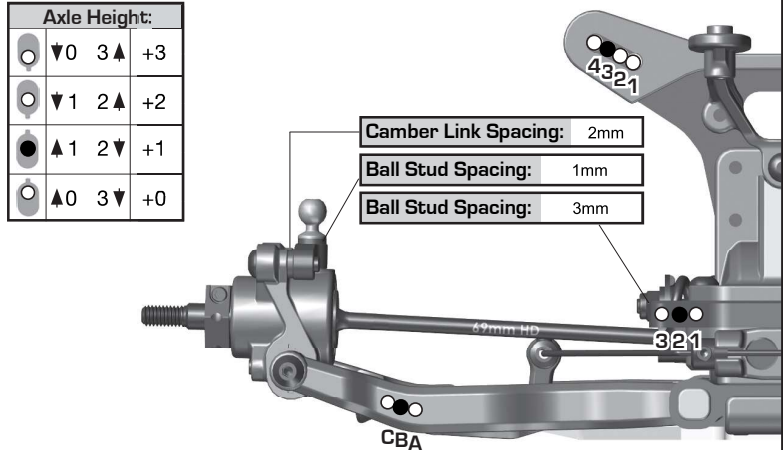
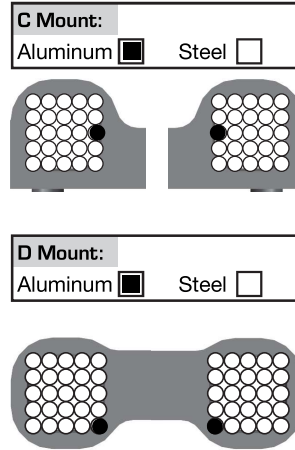

### Electronics:

Radio: Sanwa M17 (5S Feel) Servo: #27119 Reedy RT1705A  
 EPA: Throttle: 100 % Brake: 90 %  
 ESC: #27017 Reedy Blackbox 610R  
 ESC Settings: See Setup Sheet  
 Motor / Wind: #27490 Reedy Sonic M4 7.5T DE Timing: 20°  
 Pinion: #1339 FT 21T Spur: #92295 Octalock 78T  
 Battery Mount: Std  Offset  Forward  
 Battery: #27396 Reedy Zapper 4800 LP Weight: None  
 Notes: #1370 FT Servo Horn, 25T (2mm Ballstud Spacing)

### Drivetrain:

Differential: Ball Diff:   
 Height: 1 Gear Diff:   
 Diff Setting: #91918 FT Diff Decoder = 220  
 Notes:  
 Slipper Clutch:  
 Type: #92450 & 91803 Kit  
 # of Pads: #92285 FT Octalock LCF x 2  
 Setting: Front Tires Lift 1.5°  
 Notes:

### Shocks:

	Front	Rear
Piston:	2 x 1.8	2 x 1.9
Thickness:	#91934 2.5mm	#92428 2.5mm
Fluid:	#5472 FT 30wt	#5471 FT 27.5wt
Spring:	#91941 13mm Gray	#91948 13mm White
Limiters:	Int: 0 Ext: 0	Int: 0 Ext: 0
Stroke:	23.0mm	28mm
Eyelet:	+2mm	+4mm
Cup Offset:	0 <input type="checkbox"/> +5 <input checked="" type="checkbox"/> +9 <input type="checkbox"/>	0 <input type="checkbox"/> +5 <input type="checkbox"/> +9 <input type="checkbox"/>
Kashima Bodies:	<input checked="" type="checkbox"/>	Chrome Shafts: <input checked="" type="checkbox"/> Machined Spacers: <input checked="" type="checkbox"/>
Notes:		

### Track Info:

Size: Medium  
 Surface: Natural Dirt  
 Traction: Medium-High  
 Moisture: Misted  
 Condition: Grooved & Blow Off  
 Temperature: 60F  
 Notes: Grip Increases With More Cars

### Tires:

Front Tires: JConcepts Smoothie2 (Sidewalls Glued)  
 Front Compound: Silver  
 Front Insert: JConcepts Dirt Tech  
 Rear Tires: JConcepts Smoothie2  
 Rear Compound: Silver  
 Rear Insert: JConcepts Dirt Tech  
 Wheel (F/R): #9690 & 9695 Team Associated 12mm  
 Notes: SXT Baja Max

### Body, Weight:

Body: #92423 FT Lightweight RC10B7  
 Front Wing: #92425 Team Associated RC10B7  
 Rear Wing: #92424 Team Associated RC10B7 7"  
 Wing Angle: 0°  3°  6°   
 Chassis Length: #92400 RC10B7  
 Servo Weights: None  
 Electronic Weights: #91975 FT Carbon Fiber  
 Total Vehicle Weight: 1500g

### Vehicle Comments:

Notes: #92360 FT Titanium Turnbuckle Set  
 #91750, 91751, 91752 & 91753 FT Titanium Ballstuds  
 Schelle Titanium Screws