



# RC 1:10 CHAMPIONS COMPETITION

1:10 Scale 4WD Electric Off Road  
Competition Buggy Kit



#90044 RC10B74.2 CE TEAM KIT

1:10 Scale 4WD Electric Off Road Competition Buggy Manual



CHAMPIONS *by* DESIGN

AssociatedElectrics.com

TEAM ASSOCIATED

## :: Bag 3 - Step 1

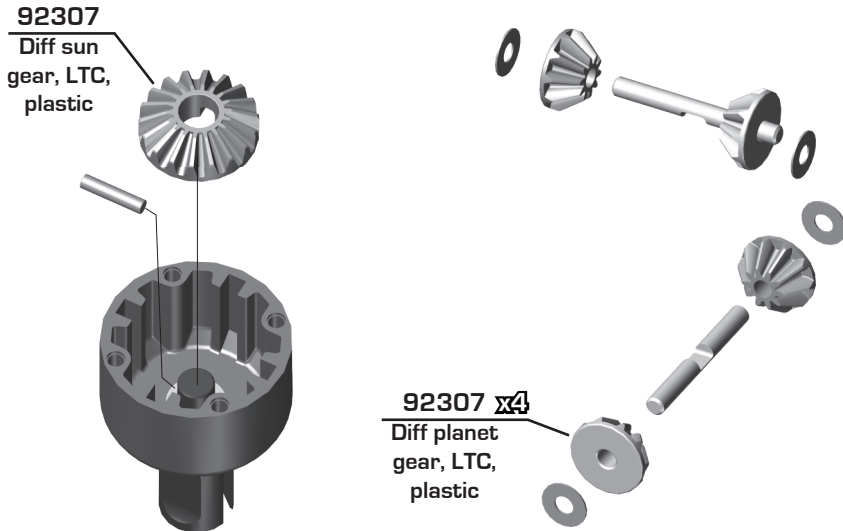

## :: Bag 3 - Step 2

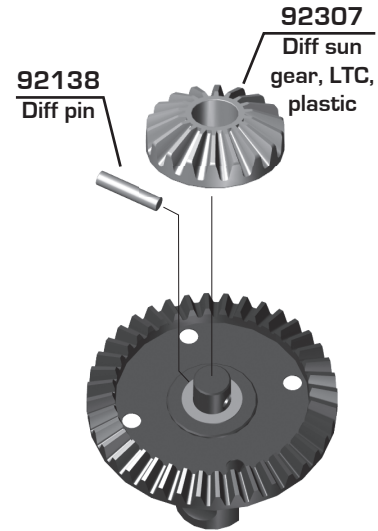

## :: Bag 3 - Step 2

Remove the machined pinion gear and replace with molded pinion gear included in this set. Note that #92319 Pinion Gear Shim (5x6.5x1mm) will not be used with the molded pinion gear. Assemble molded ring gear and strengthening ring to diff case as shown below.



Be sure not to over-tighten the ring gear screws. This will lead to the gear warping.

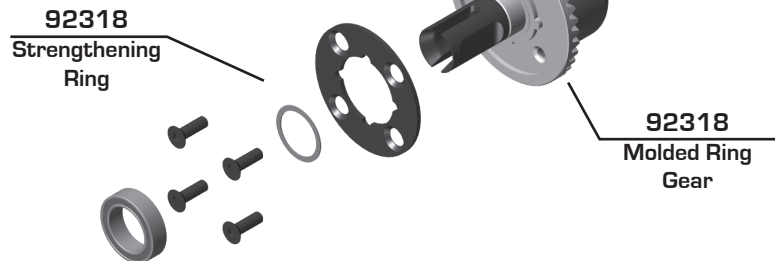

## :: Bag 4 - Steps 1, 3, and 4

Both front and rear differentials should be shimmed tight from the start so that you can feel the teeth when you spin the pinion gear (one shim on both sides of the diff case side should be the default starting position). The gear mesh should be checked after the first couple of runs to tighten it back up if it has loosened. #92139 RC10B74 Differential Outdrive Shims can be used to finely adjust the mesh.

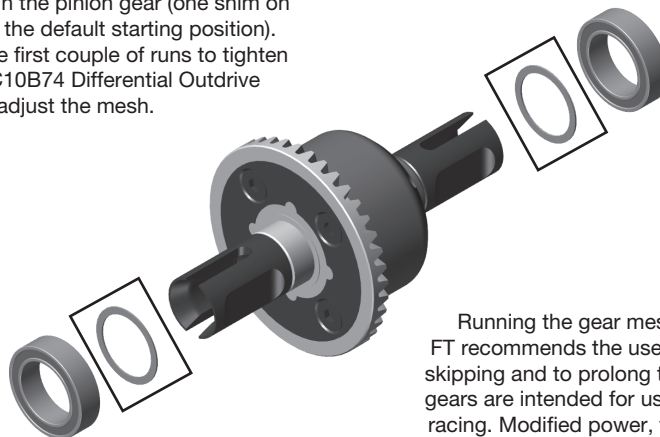

Running the gear mesh loose can result in premature failure. FT recommends the use of #6636 Silicone Grease to prevent gear skipping and to prolong the life of the gears. Please note that these gears are intended for use with a center differential and stock class racing. Modified power, the use of a slipper clutch, and running on carpet or astro turf can lead to early failure of these gears.

## :: Bag 7 - Step 1

Build x2  
(1 left side, 1 right side)

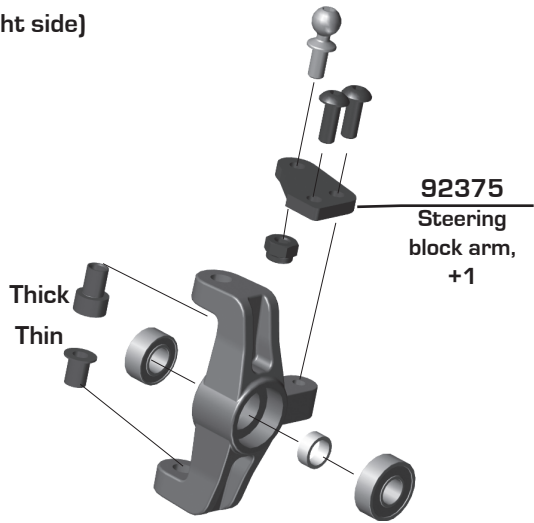

## :: Bag 7 - Step 2

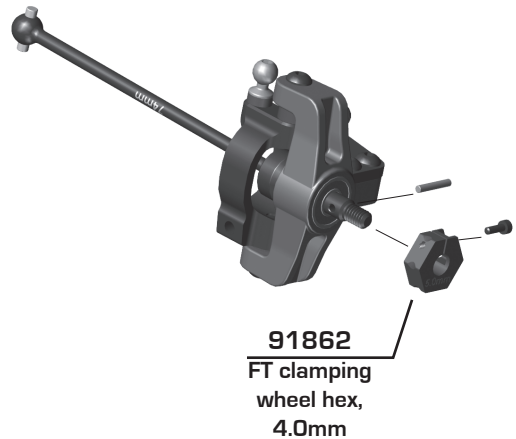

## :: Bag 10 - Step 1

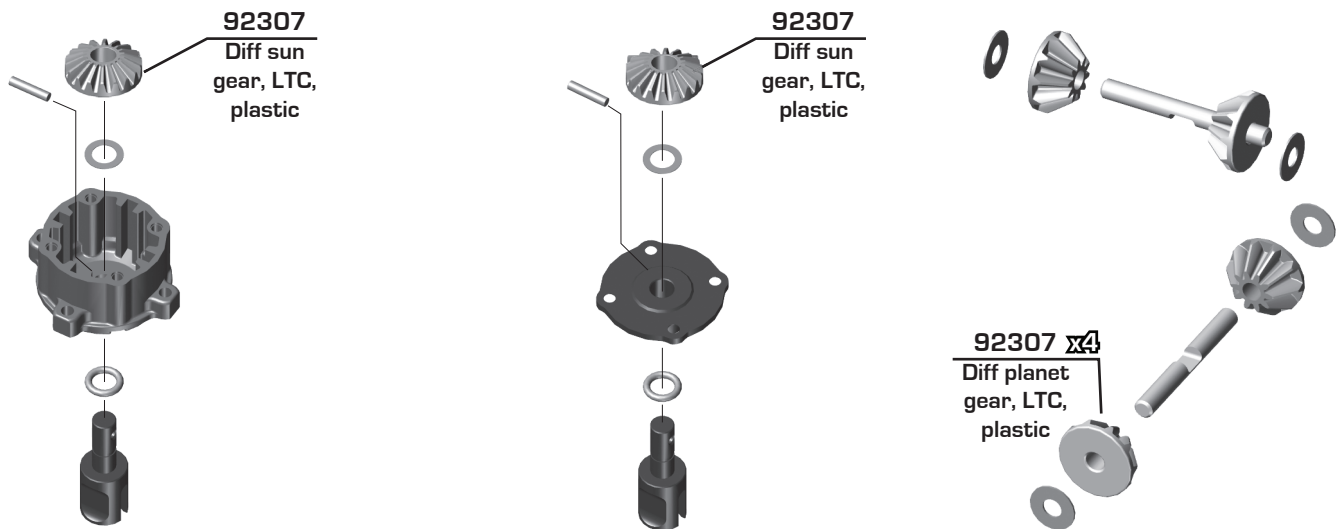

## :: Bag 11 - Step 1

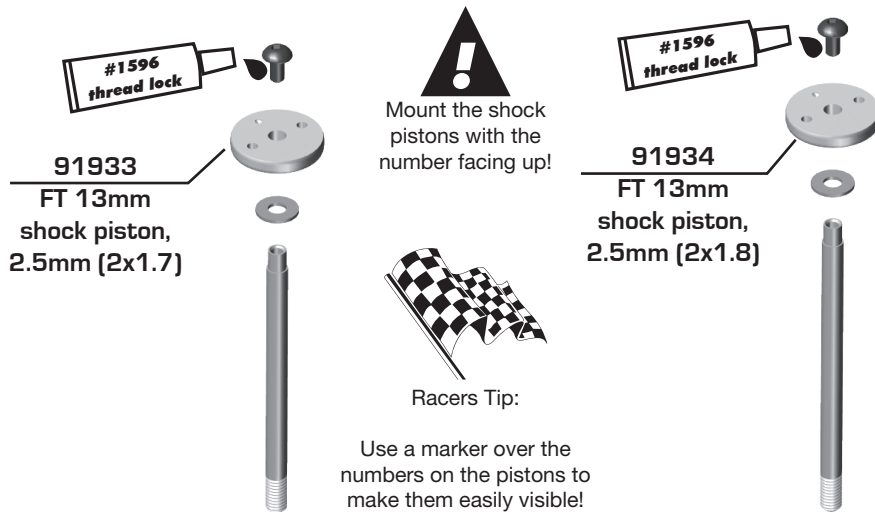

Build x2 front shocks

Build x2 rear shocks

## :: Bag 11 - Step 4

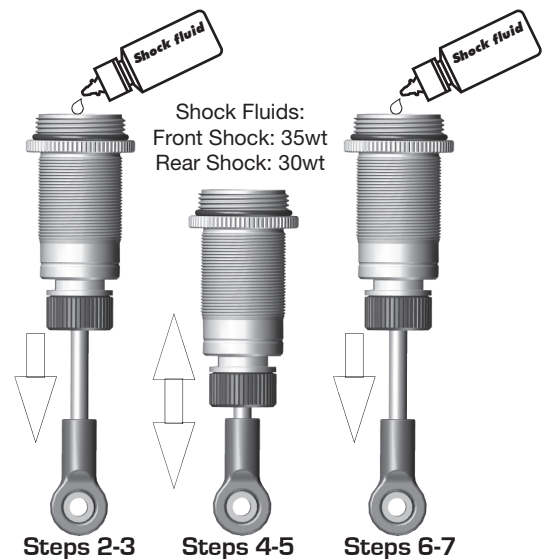

### Front Suspension:

|                        |   |
|------------------------|---|
| Ride Height:           | <b>18mm</b>   |
| Camber:                | <b>-1deg</b>  |
| Toe:                   | <b>1deg</b>   |
| Anti-Roll Bar:         | <b>1.2mm</b>  |
| Arm Type:              | <b>Gull Wing - Standard</b>   |
| Tower Type:            | <b>Gull Wing</b>  |
| Wheelbase Shim:        | <b>1mm behind arm</b>   |
| Wheel Hex:             | <b>4.0mm</b>  |
| Caster Block:          | 8° <input type="checkbox"/> 9° <input checked="" type="checkbox"/> 10° <input type="checkbox"/> |
| Chassis Brace Support: | <b>2mm G10</b>  |
| Top Plate Brace:       | <b>None</b>   |
| Front Axles:           | CVA <input checked="" type="checkbox"/> DCV <input type="checkbox"/>                            |
| Notes:                 | _____   |

1  2

Front Chassis Brace Screws:



Ball Stud Spacing: **3mm**

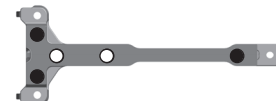

Arm Mount A: 1°  0.5°   
 Gray  Black

Diff Height:  
 +2   
 +0



Arm Mount B: 1°  0.5°   
 Gray  Black



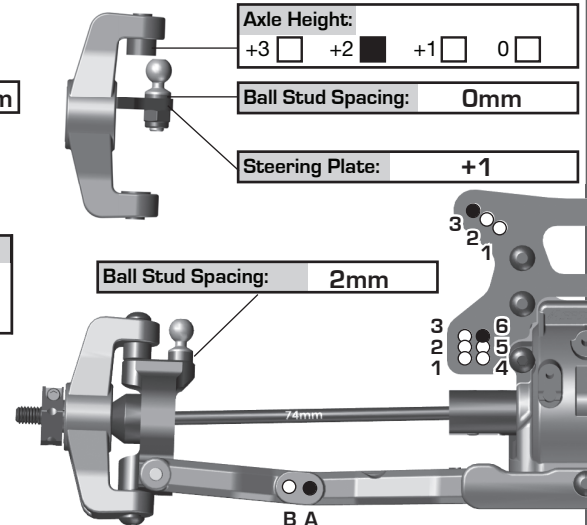

Steering Plate: **+1**

Ball Stud Spacing: **2mm**

74mm

B A

### Rear Suspension:

|                        |  |
|------------------------|--|
| Ride Height:           | <b>18mm</b>  |
| Camber:                | <b>-1deg</b>   |
| Anti-Roll Bar:         | <b>1.3mm</b>   |
| Arm Type:              | <b>Standard</b>  |
| Wheelbase Shim:        | <b>2mm behind arm</b>  |
| Wheel Hex:             | <b>5.0mm</b>   |
| Chassis Brace Support: | <b>2mm G10</b>   |
| Hub Spacing:           | Fwd <input type="checkbox"/> Mid <input checked="" type="checkbox"/> Back <input type="checkbox"/> |
| Notes:                 | _____  |

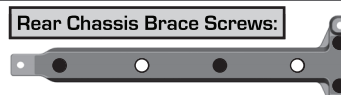
Rear Chassis Brace Screws: 

Arm Mount C: 1°  0.5°   
 Gray  Black



Arm Mount D: 1°  0.5°   
 Gray  Black

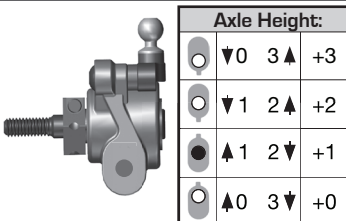

|    |    |    |
|----|----|----|
| ▼0 | 3▲ | +3 |
| ▼1 | 2▲ | +2 |
| ▲1 | 2▼ | +1 |
| ▲0 | 3▼ | +0 |

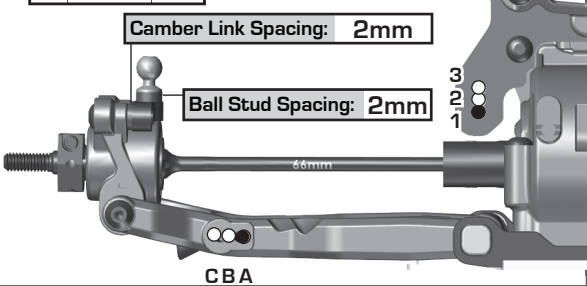

Camber Link Spacing: **2mm**

Ball Stud Spacing: **2mm**

46mm

C B A

### Electronics:

|   |                  |
|---|------------------|
| Radio:  | Servo:           |
| EPA: Throttle: %  | Brake: %         |
| ESC:  |                  |
| ESC Settings:   |                  |
| Motor / Wind:   | Timing:          |
| Pinion:   | Spur: <b>78T</b> |
| Battery:  |                  |
| Battery Position:   |                  |
| Back 1 <input type="checkbox"/> 2 <input type="checkbox"/> 3 <input checked="" type="checkbox"/> 4 <input type="checkbox"/> Forward |                  |
| Battery Weight:   |                  |

### Differential:

|                 |                                     |                |                |
|-----------------|-------------------------------------|----------------|----------------|
|                 | Front                               | Center         | Rear           |
| Fluid:          | <b>10K</b>                          | <b>200K</b>    | <b>10K</b>     |
| Gears:          | <b>Plastic</b>                      | <b>Plastic</b> | <b>Plastic</b> |
| Type:           | <b>LTC</b>                          | <b>LTC</b>     | <b>LTC</b>     |
| Notes:          | <b>Molded Ring and Pinion Gears</b> |                |                |
| Slipper Clutch: |                                     |                |                |
| Type:           |                                     |                |                |
| # of Pads:      |                                     |                |                |
| Setting:        |                                     |                |                |

### Shocks:

|                |                   |                   |
|----------------|-------------------|-------------------|
|                | Front             | Rear              |
| Piston:        | <b>2x1.7</b>      | <b>2x1.8</b>      |
| Thickness:     | <b>2.5mm</b>      | <b>2.5mm</b>      |
| Fluid:         | <b>35wt</b>       | <b>30wt</b>       |
| Spring:        | <b>Yellow</b>     | <b>Blue</b>       |
| Limiters:      | Int: ___ Ext: ___ | Int: ___ Ext: ___ |
| Stroke:        | <b>22mm</b>       | <b>28.5mm</b>     |
| Eyelet Length: | <b>+2</b>         | <b>0</b>          |
| Cup Offset:    | <b>9mm</b>        | <b>0mm</b>        |
| Notes:         |                   |                   |



### Track Info:

|                   |  |
|-------------------|--|
| Size:             | Small <input type="checkbox"/> Medium <input type="checkbox"/> Large <input type="checkbox"/> Extra Large <input type="checkbox"/>   |
| Surface:          | Dirt <input type="checkbox"/> Carpet <input type="checkbox"/> AstroTurf <input type="checkbox"/> Multi Surface <input type="checkbox"/>  |
| Traction:         | Low <input type="checkbox"/> Medium <input type="checkbox"/> High <input type="checkbox"/> Very High <input type="checkbox"/>  |
| Moisture:         | Dry <input type="checkbox"/> Damp <input type="checkbox"/> Wet <input type="checkbox"/>  |
| Condition:        | Indoor <input type="checkbox"/> Outdoor <input type="checkbox"/> Dusty <input type="checkbox"/> Hard Packed <input type="checkbox"/><br>Bumpy <input type="checkbox"/> Grooved <input type="checkbox"/> Smooth <input type="checkbox"/> Loamy <input type="checkbox"/> |
| Temperature:      | Ambient: _____ Track: _____  |
| Notes:            | _____  |
| Vehicle Comments: | _____  |

### Tires:

|                 |       |
|-----------------|-------|
| Front Tires:    | _____ |
| Front Compound: | _____ |
| Front Insert:   | _____ |
| Rear Tires:     | _____ |
| Rear Compound:  | _____ |
| Rear Insert:    | _____ |
| Wheel (F/R):    | _____ |
| Notes:          | _____ |

### Body, Wing, Weight:

|                       |   |
|-----------------------|---|
| Body:                 | <b>Kit - Lightweight</b>  |
| Front Wing:           | Yes <input type="checkbox"/> No <input checked="" type="checkbox"/> |
| Rear Wing:            | <b>Kit</b>  |
| Wing Angle:           | 0° <input type="checkbox"/> 6° <input checked="" type="checkbox"/>  |
| Wing Mount Height:    | 0 <input checked="" type="checkbox"/> -2 <input type="checkbox"/>   |
| Servo Weights:        | _____   |
| Electronic Weights:   | _____   |
| Total Vehicle Weight: | _____   |



## :: Introduction

Thank you for purchasing this Team Associated product. This assembly manual contains instructions and tips for building and maintaining your new vehicle. Please take a moment to read through the manual and familiarize yourself with the steps. We are continually changing and improving our designs; therefore, actual parts may appear slightly different than the illustrations. New parts will be noted on supplementary sheets located in the appropriate parts bags. Check each bag for these sheets before you start to build.

## :: RC10B74.2 Team Kit Features

### Champions by Design

As tires, motors, batteries, and tracks evolve, Team Associated adapts and improves with every iteration of the RC10. The engineers at Team Associated's Area 51 set out to extract more performance from the RC10B74 4WD buggy platform with the introduction of the RC10B74.2 and RC10B74.2D. Our goals were to reduce overall weight, lower the center of gravity, and improve jump and bump handling. The differentials were modified to improve rolling speed through turns and increase stability on landings, allowing the buggy to corner faster on high-grip carpet and clay tracks.

The RC10B74.2 and RC10B74.2D introduce molded gearboxes front and rear, which lower the center of gravity by removing weight from high points of the car. The latest 13mm big bore shock technology from Team Associated is included, taking the RC10B74.2 to the next level in jump and bump handling performance. The introduction of gull wing front suspension arms and the inclusion of the LTC gear sets for the differentials make the RC10B74.2 platform easier and more predictable to drive on any track condition.

### RC10B74.2D Team Kit Features:

- New lightweight molded gearboxes front and rear
- Two fixed height front gearboxes allowing 0 and +2mm diff height options
- One rear gearbox with RC10B6-style inserts allowing 0, +1, +2, and +3mm diff height options
- New 13mm big-bore threaded aluminum shocks and springs with machined shock pistons for improved bump and jump handling
- New gull wing front suspension arms and mating shock tower for lower center of gravity and better steering predictability
- LTC differential gear sets are included. That reduce binding under power, giving more predictable power delivery
- New battery hold-down system uses inserts to adjust weight bias. O-ring style battery strap with pull tabs
- New larger 3.5mm turnbuckles with updated rod end style ballcaps to increase durability and reduce bind in the suspension
- New center bulkhead fan mount that mounts the fan above the motor for better cooling performance
- New -2mm wing mounts for use with slicks and low-profile carpet tires to further lower the center of gravity
- Center differential with 72T and 78T spur gear and 200,000 CST silicone diff fluid
- +3mm aluminum steering rack for optimized bump steer at low ride heights
- 66mm Rear CVA drive shafts and axles for more on-power traction and more predictable driving feel

## :: Additional

Your new B74.2 Team Kit comes unassembled and requires the following items for completion (refer to catalog section for suggestions):

- |   |  |
|---|--|
| <ul style="list-style-type: none"> <li>• R/C two channel surface frequency radio system</li> <li>• AA-size batteries for transmitter (#302 alkaline)</li> <li>• Electronic Speed Control, ESC (#27004, 27033)</li> <li>• Steering servo (#27117, 27118, 27119)</li> <li>• R/C electric motor</li> <li>• Pinion gear (48P), size determined by type/turn or kV of motor</li> </ul> | <ul style="list-style-type: none"> <li>• Battery charger<br/>(a peak detection charger, or LiPo compatible charger)</li> <li>• 2 cell LiPo battery pack (#27382, 27383, 27384)</li> <li>• Polycarbonate specific spray paint</li> <li>• Cyanoacrylate glue (CA)(#1597)</li> <li>• Thread locking compound (#1596)</li> <li>• Tires and Inserts, Fronts and Rears</li> <li>• Wheels w/12mm Hex<br/>Front Wheels#92095, #92096<br/>Rear Wheels #9695, #9696</li> </ul> |
|---|--|

## :: Other Helpful Items

- |   |   |   |   |
|---|---|---|---|
| <ul style="list-style-type: none"> <li>• Silicone Shock Fluid (Refer to catalog for complete listings)</li> <li>• FT Body Scissors (#1737)</li> <li>• FT Hex/Nut Wrenches (#1519)</li> <li>• FT Universal Tire Balancer (#1498)</li> <li>• FT Dual Turnbuckle Wrench (#1114)</li> </ul> | <ul style="list-style-type: none"> <li>• FT Body Reamer (#1499)</li> <li>• Needle Nose Pliers</li> <li>• Calipers or a Precision Ruler</li> <li>• Green Slime shock lube (#1105)</li> </ul> | <ul style="list-style-type: none"> <li>• Shock Pliers</li> <li>• FT Ballcup Wrench (#1579)</li> <li>• Soldering Iron</li> </ul> | <ul style="list-style-type: none"> <li>• Wire Cutters</li> <li>• Hobby Knife</li> </ul> |
|---|---|---|---|



















Associated Electrics, Inc.  
21062 Bake Parkway.  
Lake Forest, CA 92630



Customer Service  
Tel: 949.544.7500  
Fax: 949.544.7501

Hardware - 1:1 Scale View









Button Head (bhcs)

|  |                  |
|--|------------------|
|    | 2x4mm (31510)    |
|    | 2.5x5mm (31519)  |
|    | 2.5x6mm (31520)  |
|    | 2.5x8mm (31521)  |
|    | 2.5x10mm (31522) |
|    | 3x4mm (91158)    |
|    | 3x5mm (31530)    |
|    | 3x6mm (31531)    |
|    | 3x8mm (31532)    |
|    | 3x10mm (25211)   |
|    | 3x12mm (89202)   |
|    | 3x14mm (25187)   |
|    | 3x16mm (89203)   |
|    | 3x18mm (2308)    |
|    | 3x20mm (25188)   |
|   | 3x22mm (25189)   |
|  | 3x24mm (89204)   |
|  | 3x30mm (91478)   |

Set Screws

|  |                 |
|--|-----------------|
|   | 3x2.5mm (31500) |
|   | 3x3mm (25225)   |
|  | 3x10mm (4671)   |

Flat Head (fhcs)

|   |                |
|---|----------------|
|  | 2x3mm (91743)  |
|  | 3x6mm (31541)  |
|  | 3x8mm (25201)  |
|  | 3x10mm (25202) |
|  | 3x12mm (25203) |
|  | 3x14mm (89208) |
|  | 3x16mm (25204) |
|  | 3x18mm (89209) |





Cap Head (shcs)

|   |                   |
|---|-------------------|
|  | 1.6 x 5mm (91611) |
|---|-------------------|







LP Socket Head (lp shcs)

|   |                |
|---|----------------|
|  | 3x6mm (41089)  |
|  | 3x22mm (41095) |









Shims and Washers

|   |                      |
|---|----------------------|
|  | 5.5x0.5mm (31381)    |
|  | 5.5x1.0mm (31382)    |
|  | 5.5x2.0mm (31383)    |
|  | 3x8mm Washer (89218) |





Ball Bearings

|   |                          |
|---|--------------------------|
|  | 4x7x2.5mm (31732)        |
|  | 5x8x2.5mm (31400)        |
|  | 5x10x4mm (91560)         |
|  | 5x10x4mm flanged (92324) |
|  | 5x12x4 (91567)           |
|  | 10x15x4 (91563)          |

Ballstuds

|   |                         |
|---|-------------------------|
|    | Silver 5mm long (31283) |
|    | Silver 8mm long (31284) |
|    | HD 6mm (91047)          |
|   | Ti HD 6mm (91751)       |
|  | HD 8mm (91048)          |
|  | Ti HD 8mm (91752)       |
|  | HD 10mm (91049)         |
|  | Ti HD 10mm (91753)      |

Nuts (lock/plain)

|   |   |
|---|---|
|  | M3 Nut (91477)                            |
|  | M3 Alum. Locknut, Blue (31550)            |
|  | M3 Locknut, Black (25215)                 |
|  | M3 Locknut w/Flange (25612)               |
|  | FT 3mm Locknuts, Blue(25392)              |
|  | M4 Locknuts:<br>Serrated Steel LP (91150) |
|  | Serrated Steel (Silver) (91826)           |
|  | FT Aluminum (Blue) (31551)                |
|  | Serrated Aluminum (Black) (91738)         |

Notes:

## :: Table of Contents

|         |  |         |                                    |
|---------|--|---------|------------------------------------|
| 1.....  | Cover  | 13..... | Rear Hubs Build<br>Bag 8           |
| 2.....  | Introduction                                   | 13..... | Turnbuckles Build<br>Bag 9         |
| 3.....  | 1:1 Hardware “Fold Out”                        | 15..... | Center Slipper Build<br>Bag 10     |
| 4.....  | Table of Contents                              | 16..... | Shocks Build<br>Bag 11             |
| 5.....  | Chassis Build<br>Bag 1                         | 17..... | Anti-Roll Bars Build<br>Bag 12     |
| 5.....  | Suspension Arms Build<br>Bag 2                 | 19..... | Electronics / Body Build<br>Bag 13 |
| 6.....  | Front / Rear Gear Differentials Build<br>Bag 3 | 22..... | Tuning Tips                        |
| 7.....  | Front / Rear Gearbox Build<br>Bag 4            | 24..... | Catalog                            |
| 8.....  | Bulkhead / Shock Tower Build<br>Bag 5          | 32..... | Setup Sheet “Kit Setup”            |
| 10..... | Steering Build<br>Bag 6                        | 33..... | Setup Sheet “Blank”                |
| 12..... | Caster Blocks Build<br>Bag 7                   | 34..... | Back Cover                         |

## :: Notes



This symbol indicates a special note or instruction in the manual.



This symbol indicates a Racers Tip.



There is a 1:1 hardware foldout page in the front of the manual. To check the size of a part, line up your hardware with the correct drawing until you find the exact size. Each part in the foldout has a number assigned to it for ordering replacement parts.

Associated Electrics, Inc.  
21062 Bake Parkway.  
Lake Forest, CA 92630



Customer Service  
Tel: 949.544.7500  
Fax: 949.544.7501

**:: Bag 1 - Step 1**

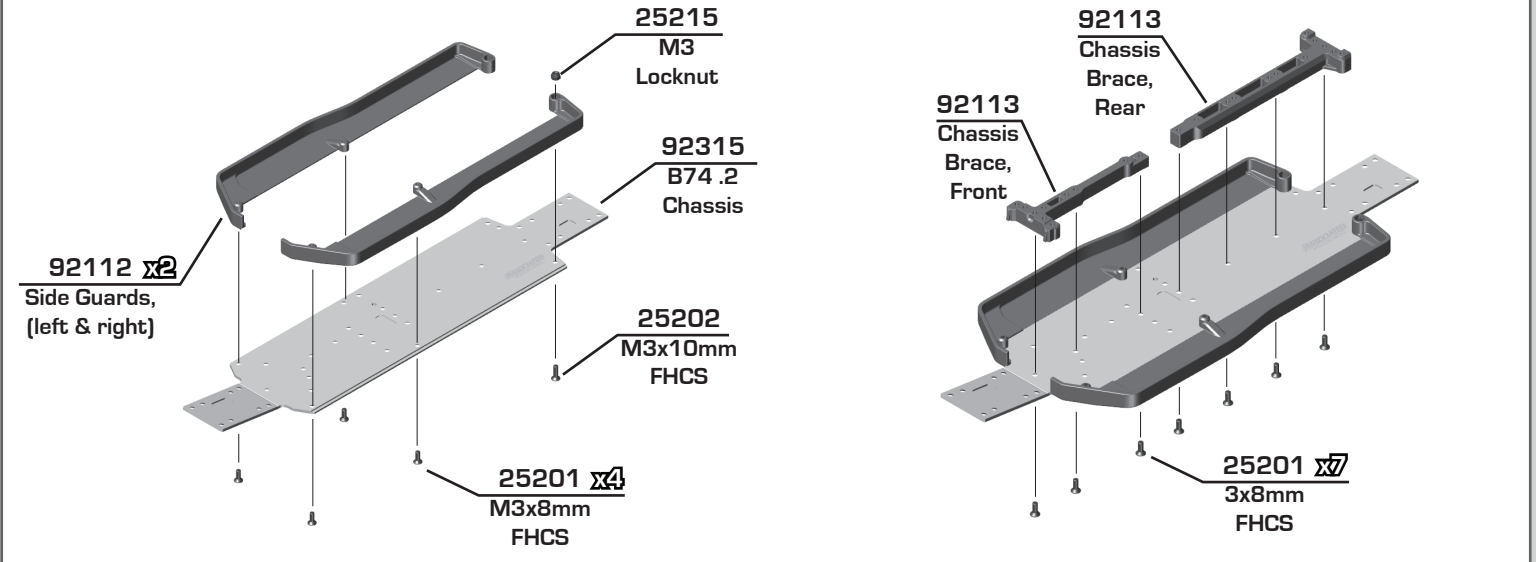

**:: Bag 1 - Step 2**

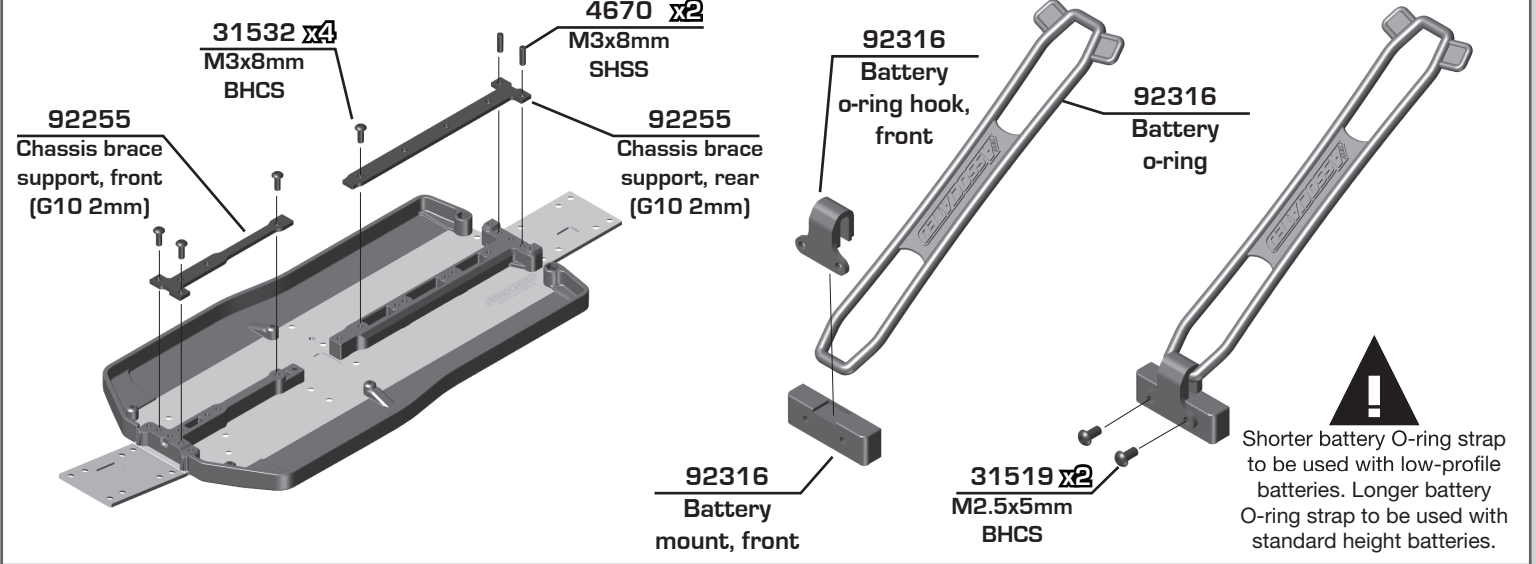

**:: Bag 1 - Step 3**

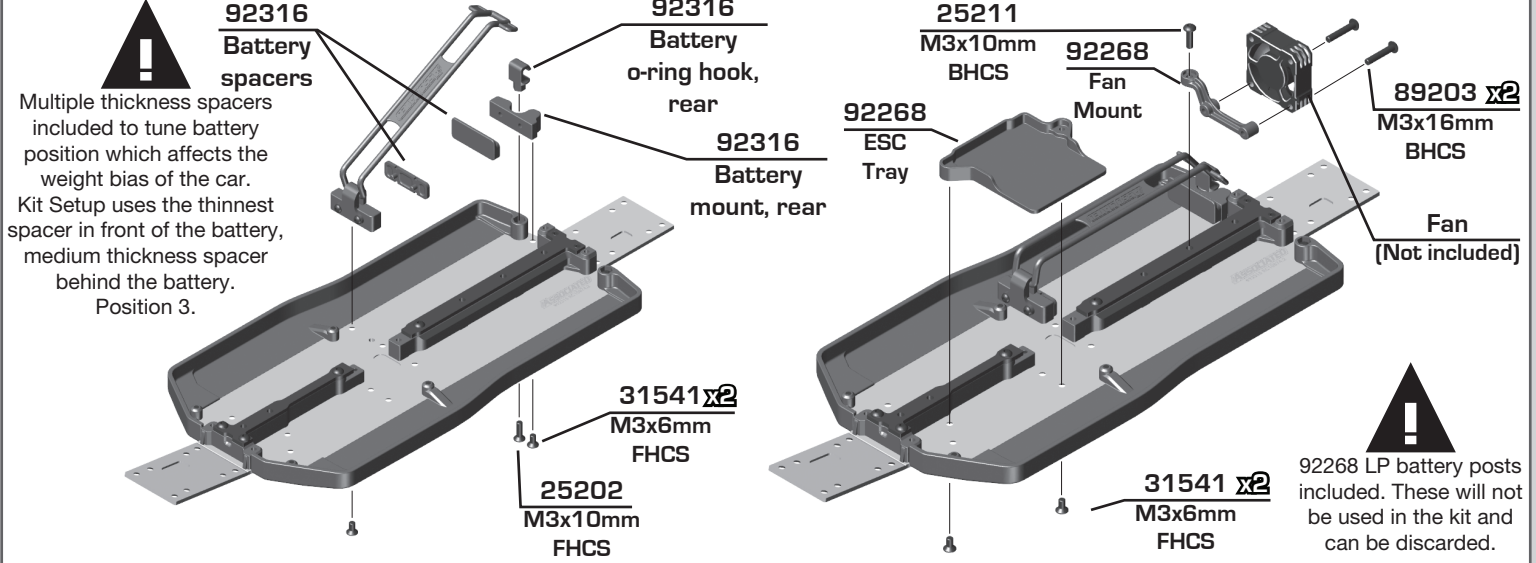

:: Bag 2 - Step 1

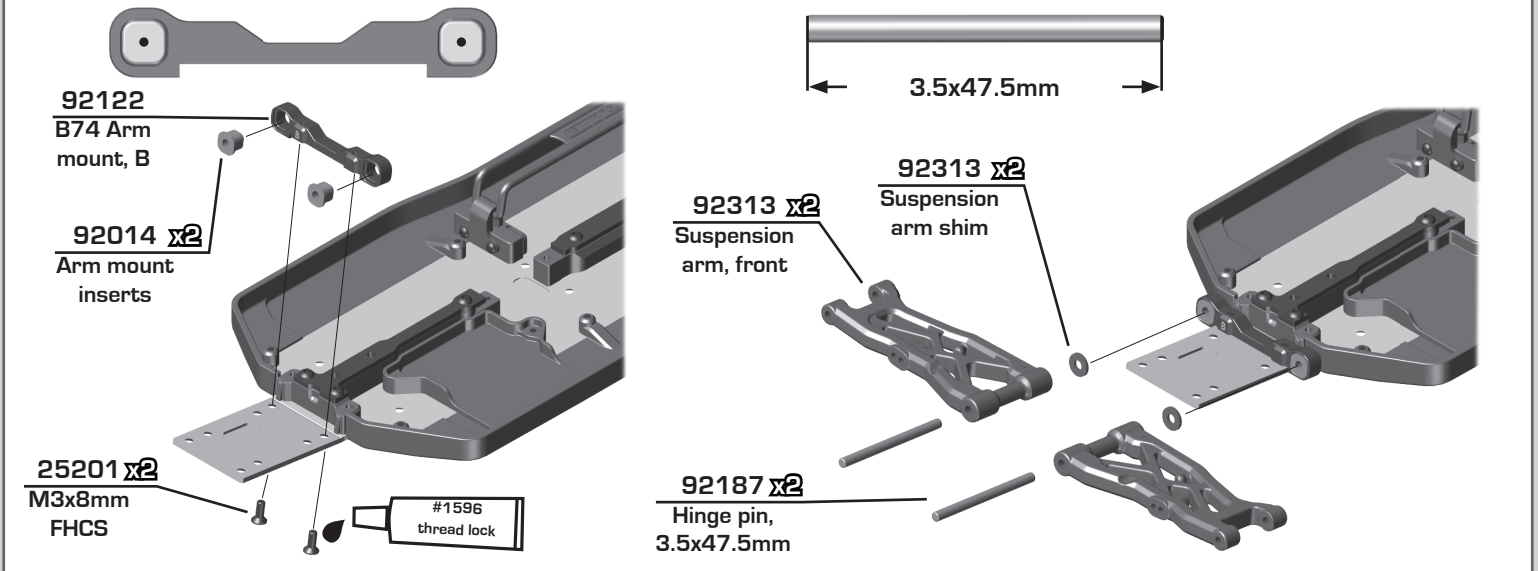

:: Bag 2 - Step 2

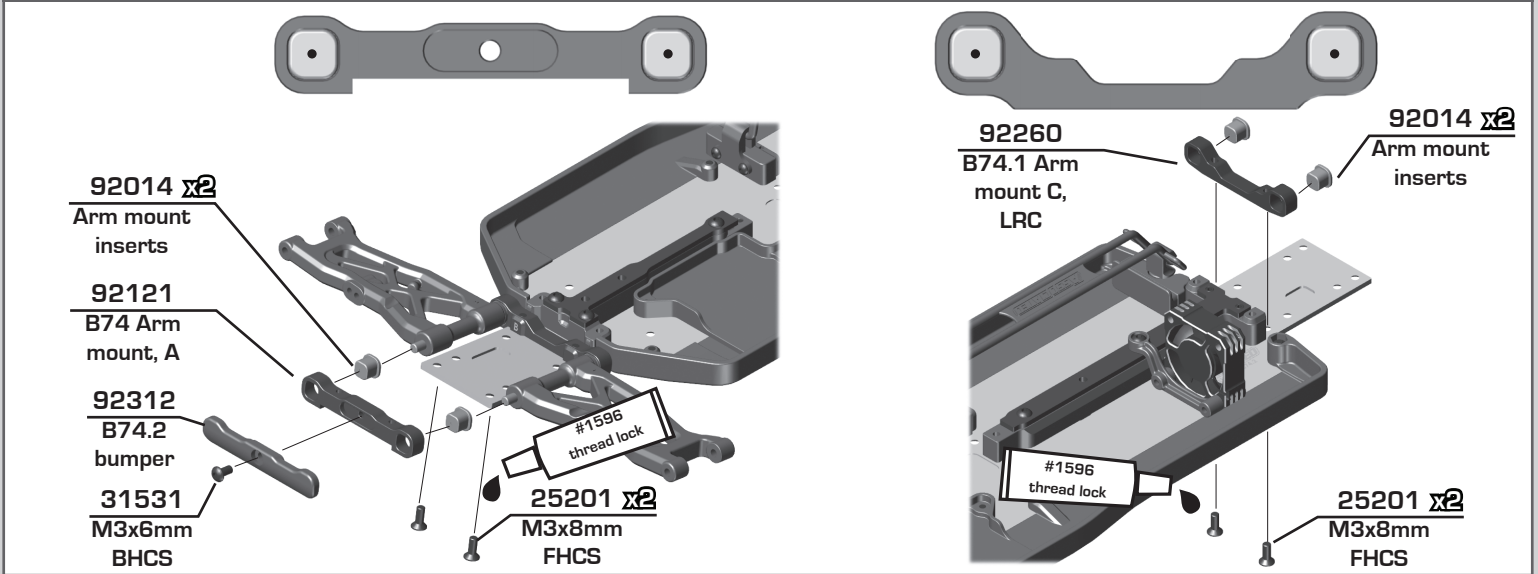

:: Bag 2 - Step 3

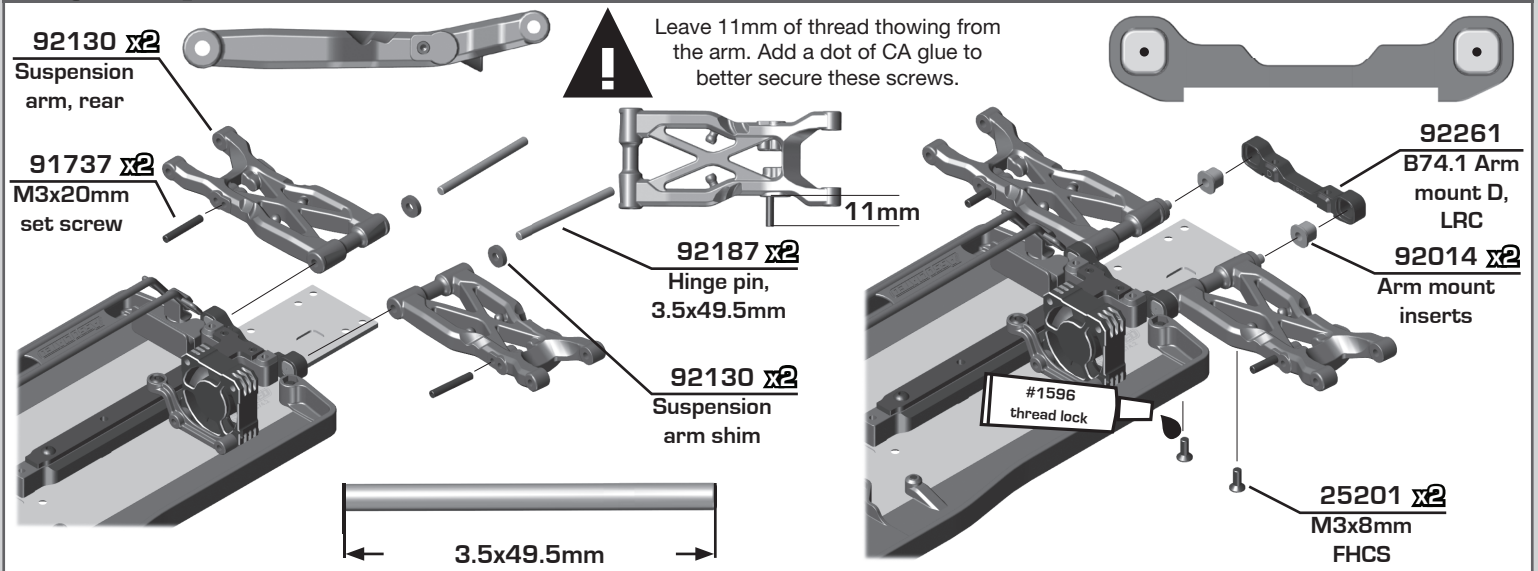



**:: Bag 3 - Step 1**

Build x2 (1 front, 1 rear)

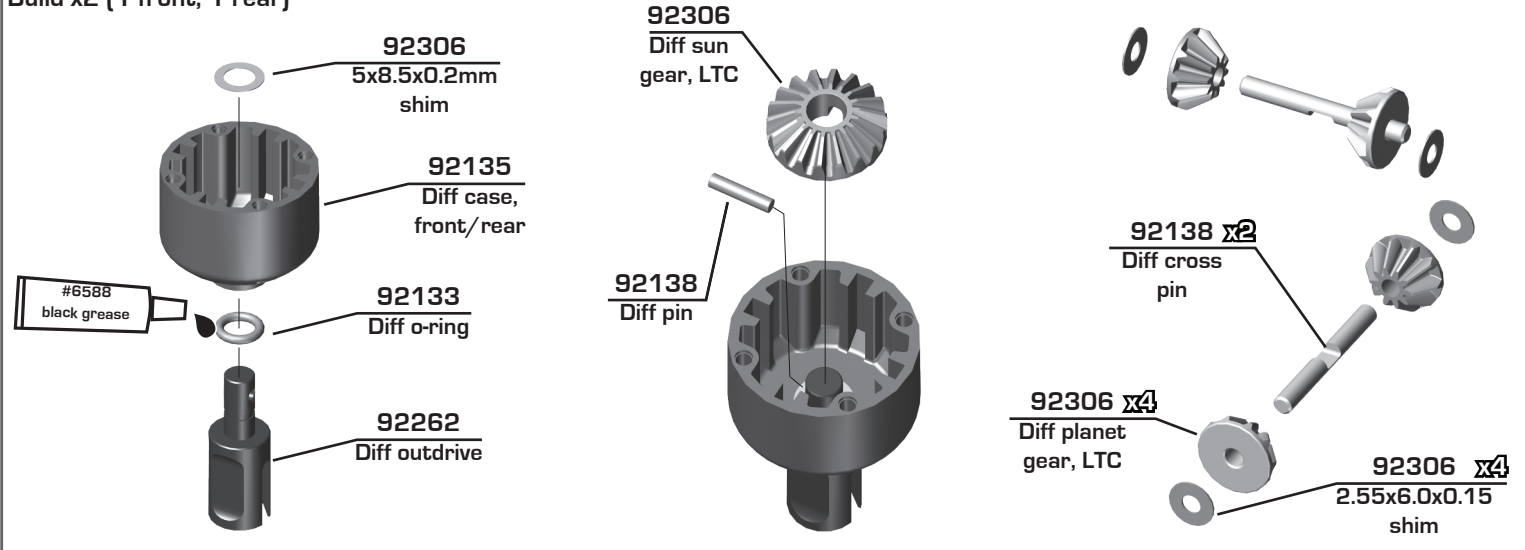

**:: Bag 3 - Step 2**

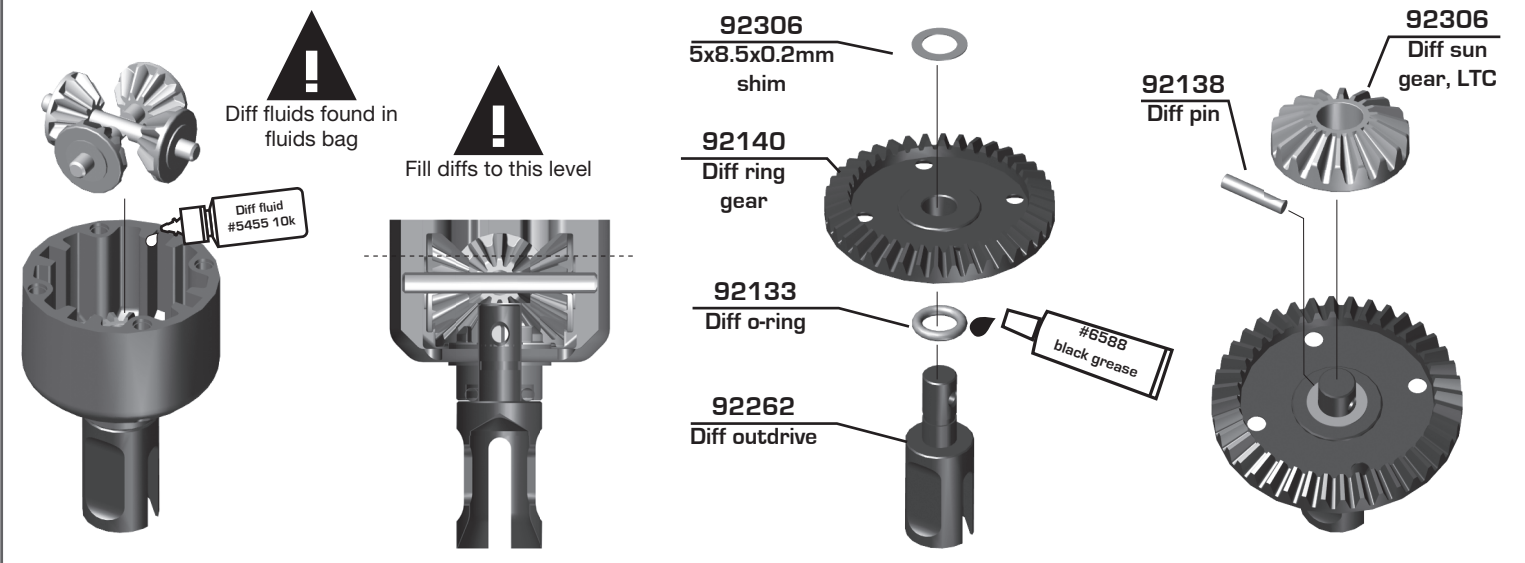

**:: Bag 3 - Step 3**



It is important that the correct amount of fluid is added to the diff. Too much fluid may cause the diff to fail. Fill diffs to the reference line shown above. A more accurate method is to use a digital scale (AE#1522) to make sure the correct amount of fluid is added on the first build, and subsequent rebuilds. The entire diff assembly should weigh **45.25g** when built. Start by placing the ring gear assembly, screws, and cup assembly (without fluid) onto the scale. Then slowly add fluid to the cup assembly until the overall mass is **45.25g**.

| B74 Diff Weights (minus bearings) |                |         |
|-----------------------------------|----------------|---------|
|                                   | Weight (grams) |         |
|                                   | Metal          | Plastic |
| F/R Differential                  | 45.25          | 36      |
| Center Differential               | 43.75          | 34.5    |

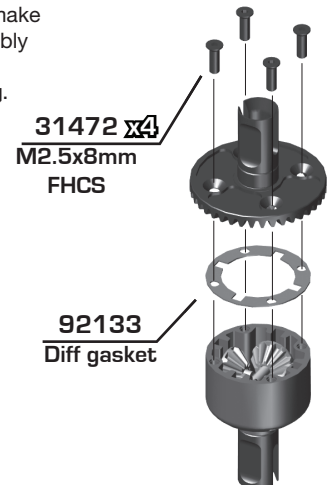
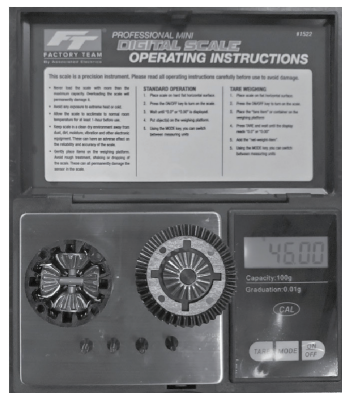

Build x2 (1 front, 1 rear)

**:: Bag 4 - Step 1**

**Build front gearbox**

**92324 x2**  
M5x10x4  
flanged bearing

**92319**  
Diff pinion  
gear shim,  
M5x6.5x1mm

**92142**  
Diff pinion  
gear

**92309**  
B74.2 front  
gearbox,  
inboard, 0

**91563 x2**  
M10x15x4  
bearing

**92139 x2**  
Diff shim

0 & 2 are included in kit.  
"0" gearbox for front,  
"2" height is optional.

Start by shimming the diff with one shim on either side of the diff. If the diff is tight when inserted into the gearbox, remove one shim from the ring gear side and add it to the diff case side.

**:: Bag 4 - Step 2**

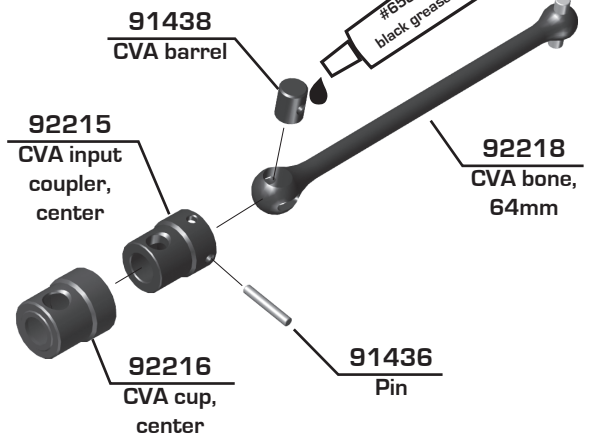
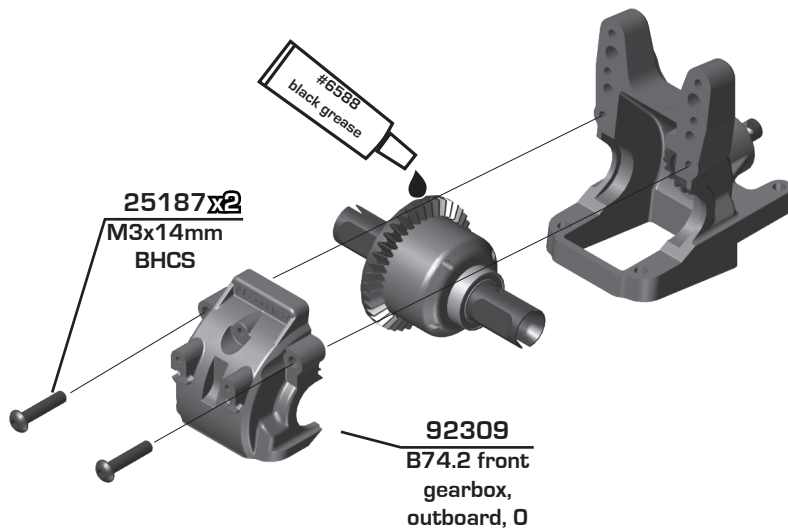

**:: Bag 4 - Step 3**

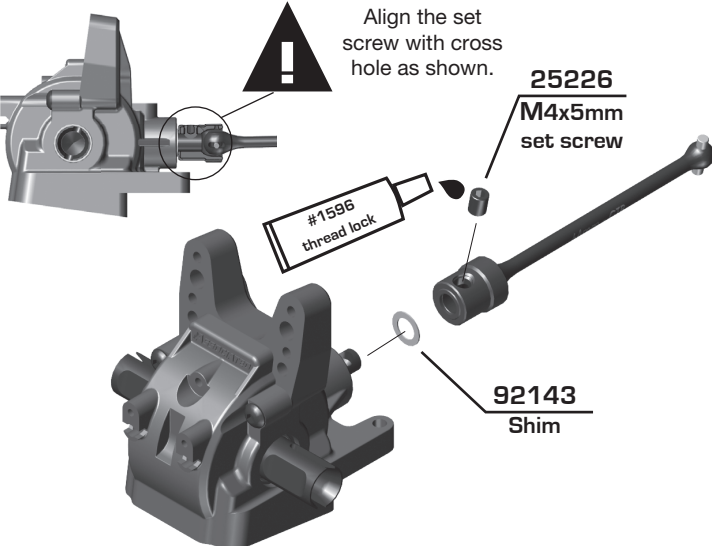

**Build rear gearbox**

**92324 x2**  
M5x10x4  
flanged bearing

**92311 x2**  
B74.2 rear  
gearbox pinion  
height insert,  
0 and 3

**92310**  
B74.2 rear  
gearbox,  
bottom

**92142**  
Diff pinion  
gear

**92319**  
Diff pinion  
gear shim,  
M5x6.5x1mm

Number shown on top of the insert after insertion should match the diff height desired. Kit setup: "0"

**:: Bag 4 - Step 4**

Start by shimming the diff with one shim on either side of the diff. If the diff is tight when inserted into the gearbox, remove one shim from the ring gear side and add it to the diff case side.

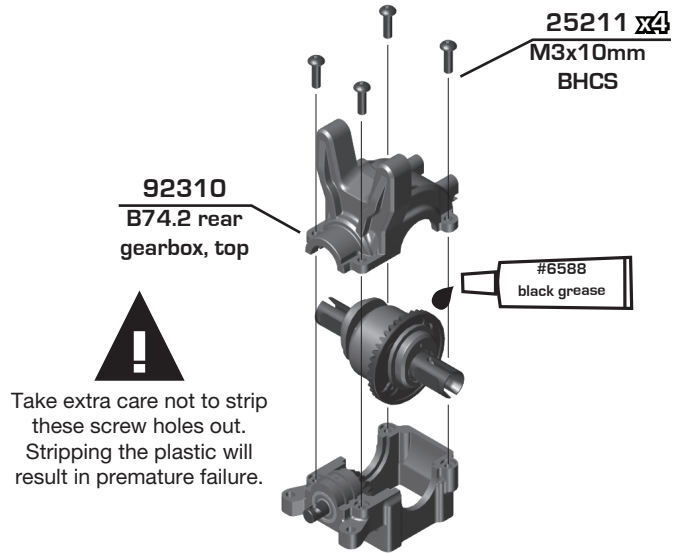
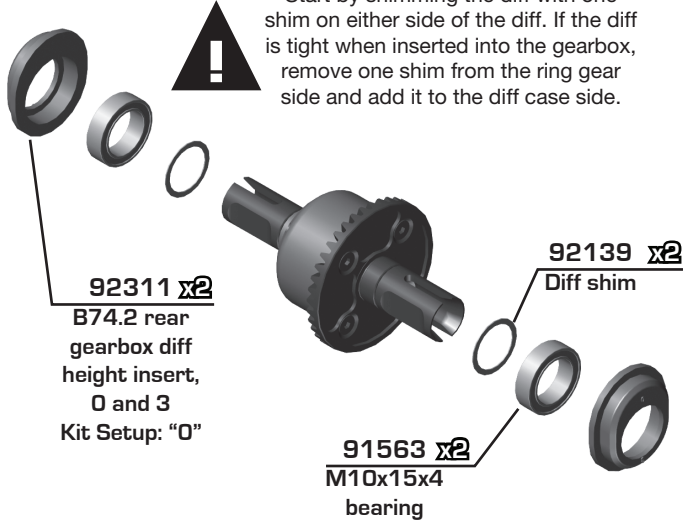

**:: Bag 4 - Step 5**

Align the set screw with cross hole as shown.

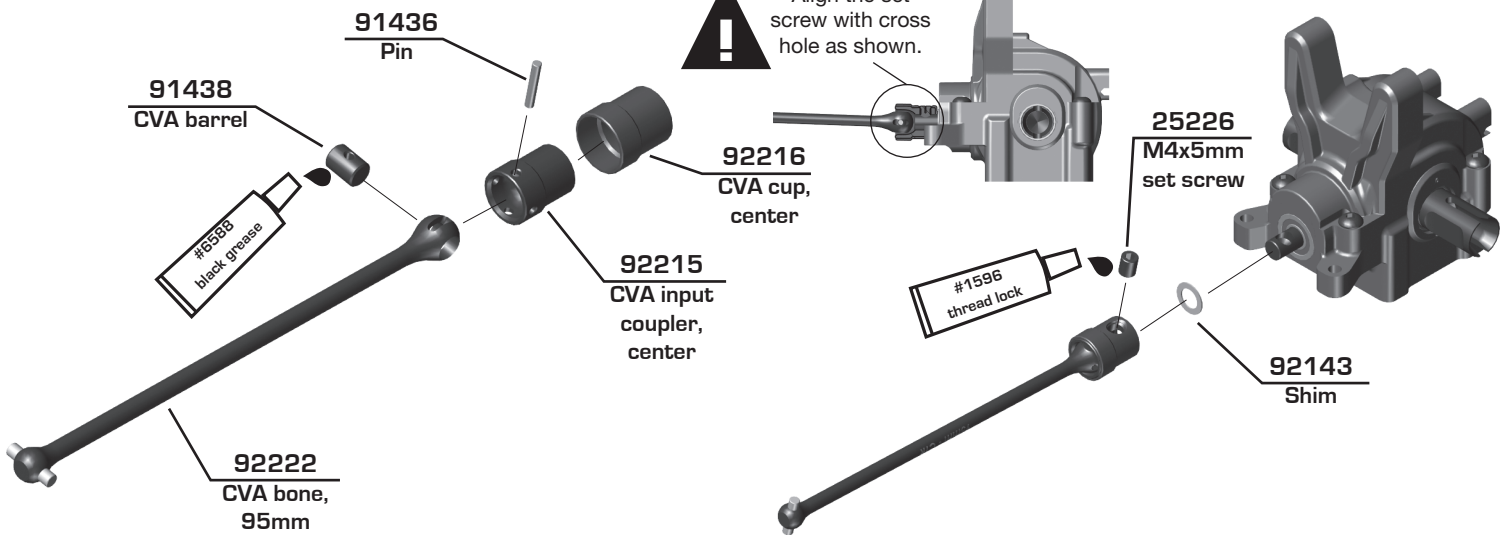

**:: Bag 4 - Step 6**

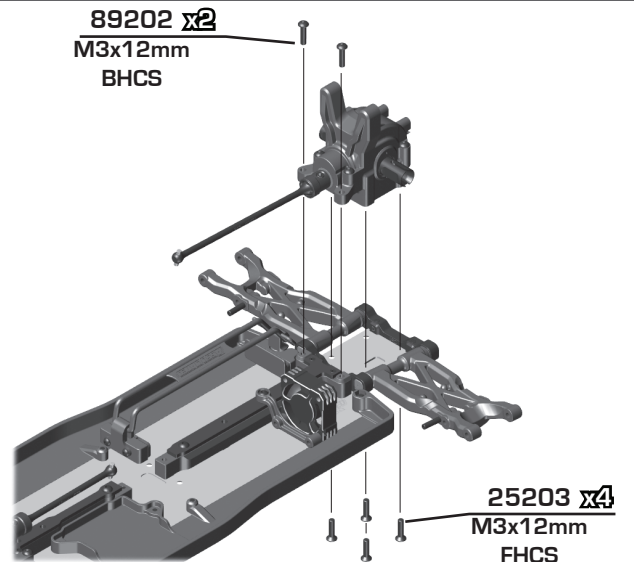
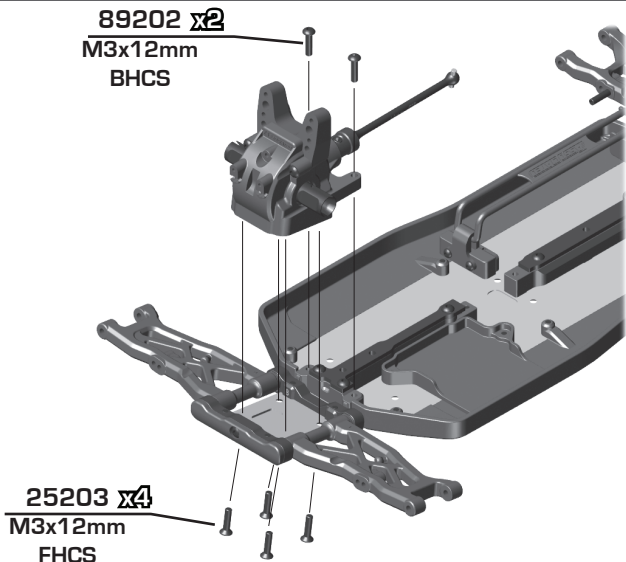

**:: Bag 5 - Step 1**

Build front shock tower

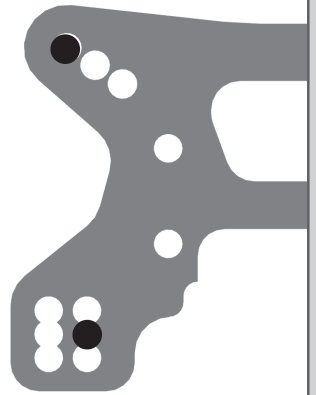
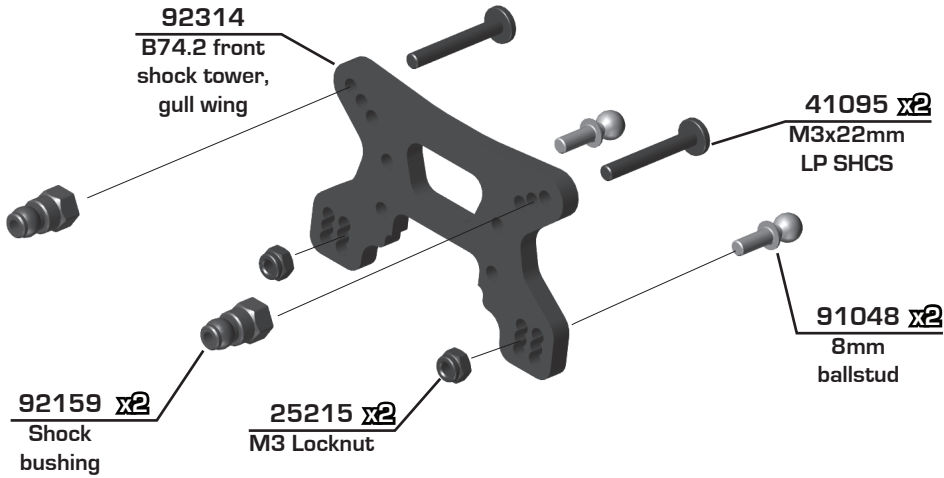

Tuning Tip: Use the shorter location for less steering and more stable front end, although this might slow cornering speed.

**:: Bag 5 - Step 2**

Build rear shock tower

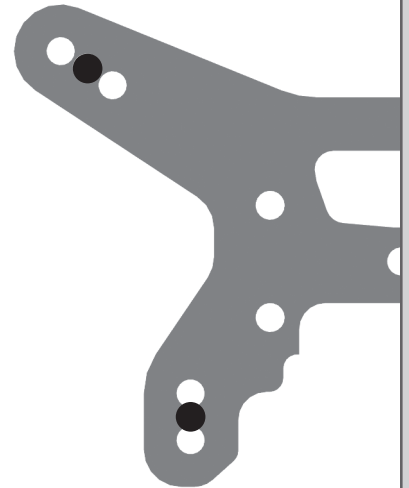
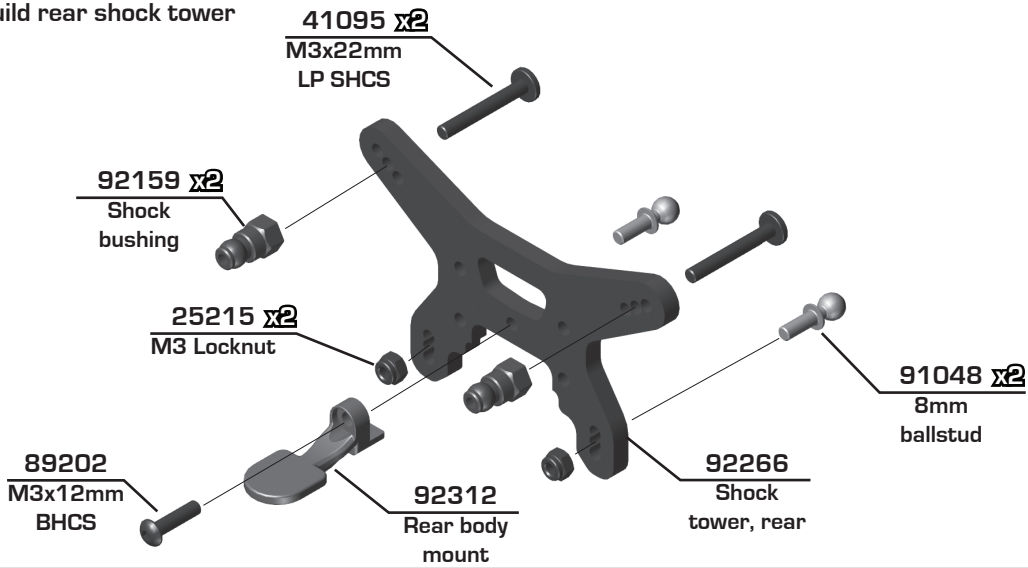

**:: Bag 5 - Step 3**

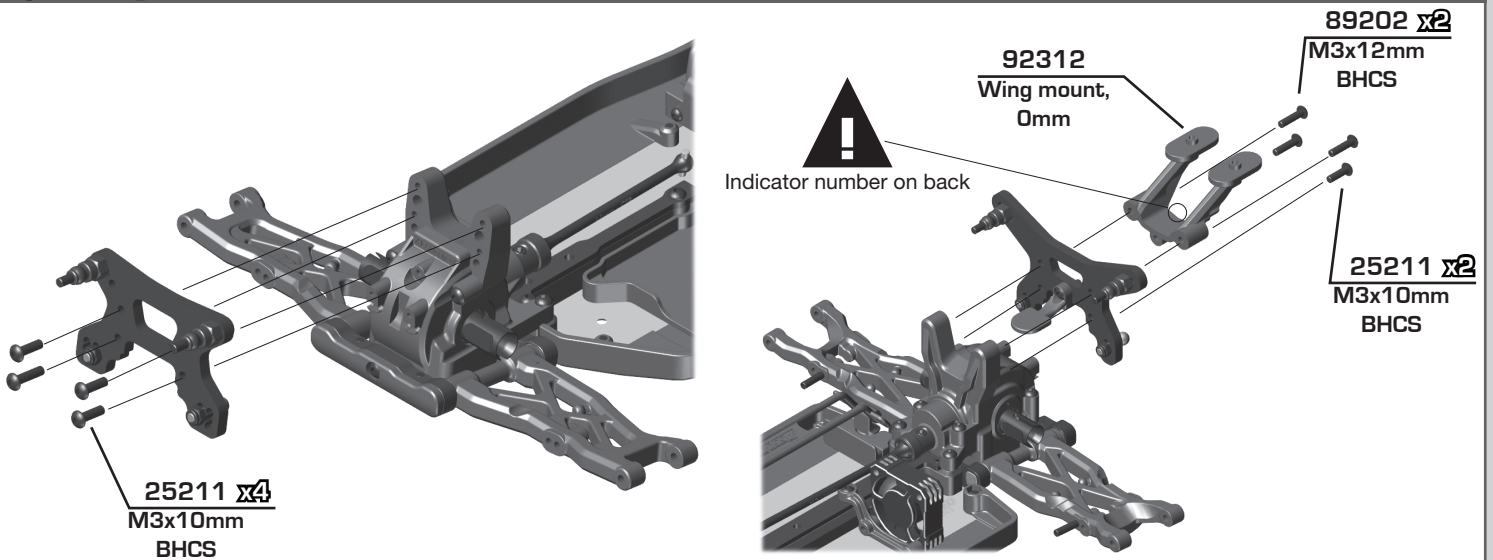

:: Bag 6 - Step 1

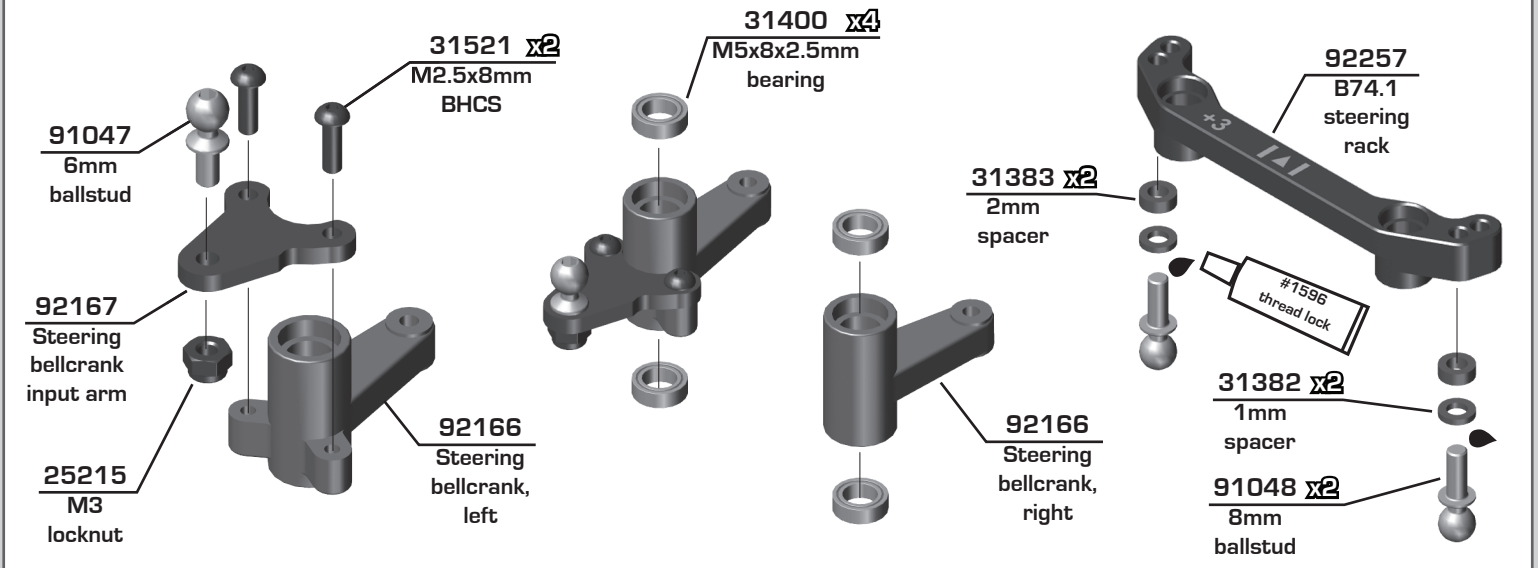

:: Bag 6 - Step 2

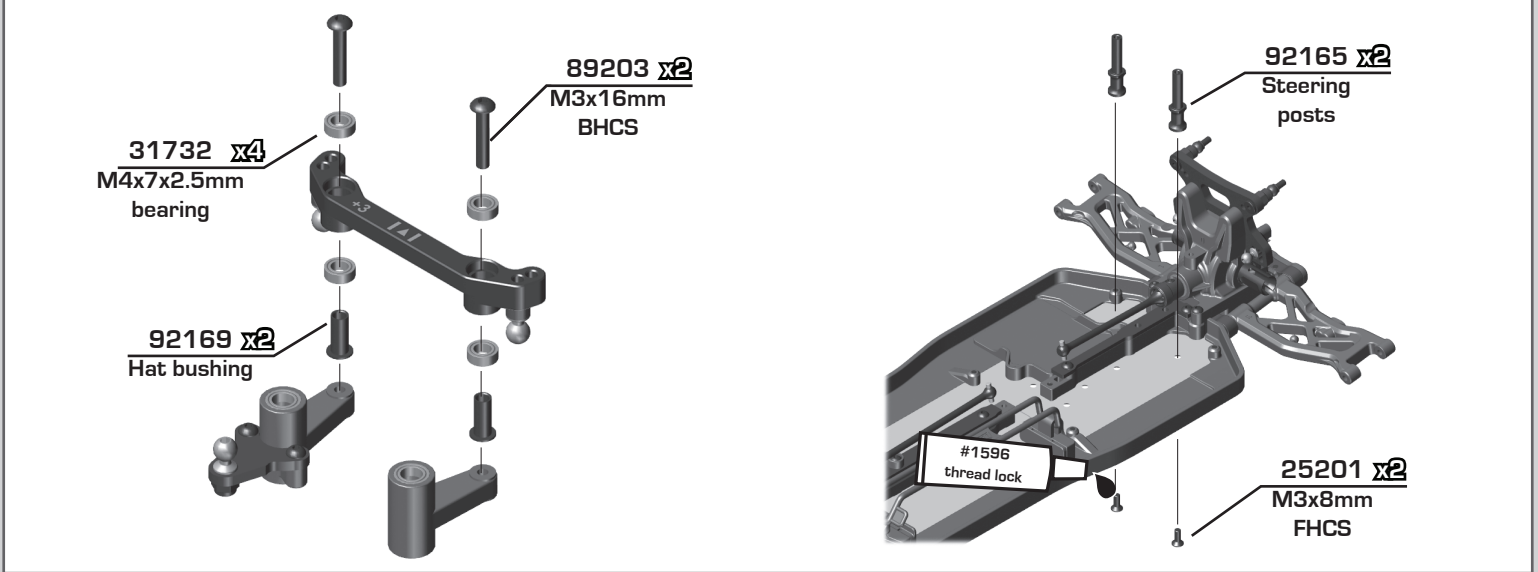

:: Bag 6 - Step 3

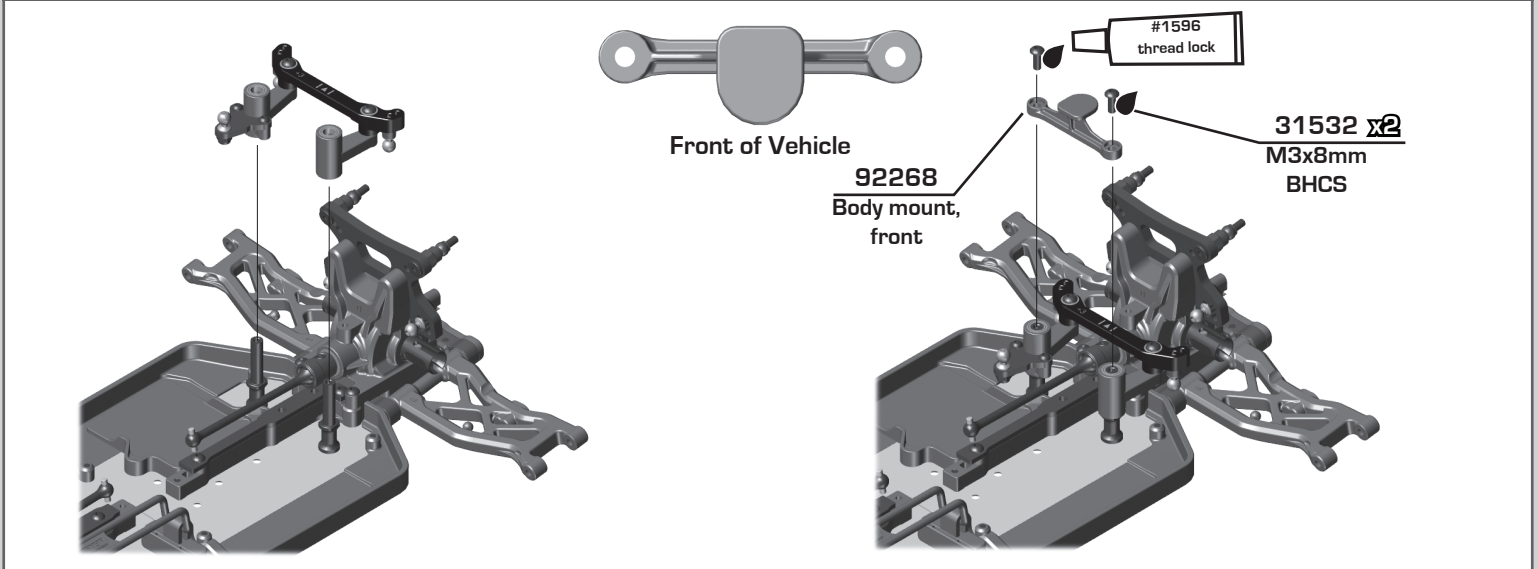



**:: Bag 7 - Step 1**

Build x2  
(1 left side, 1 right side)

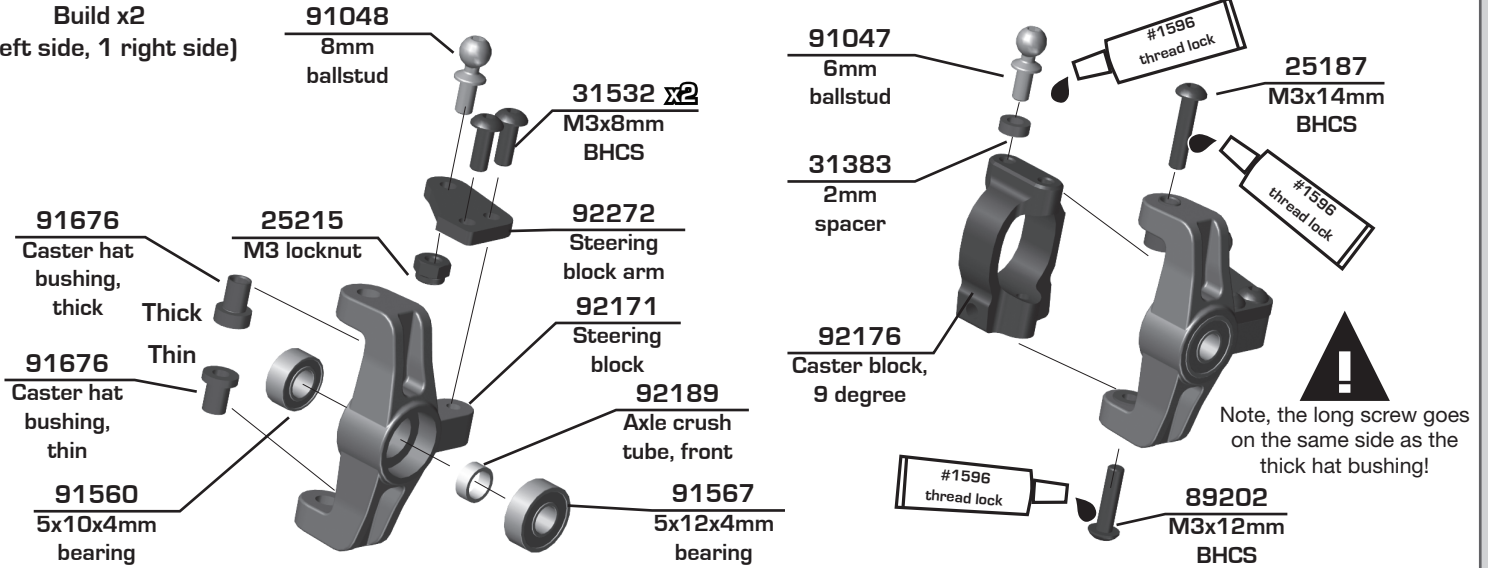

**:: Bag 7 - Step 2**

Build x2  
(1 left side, 1 right side)

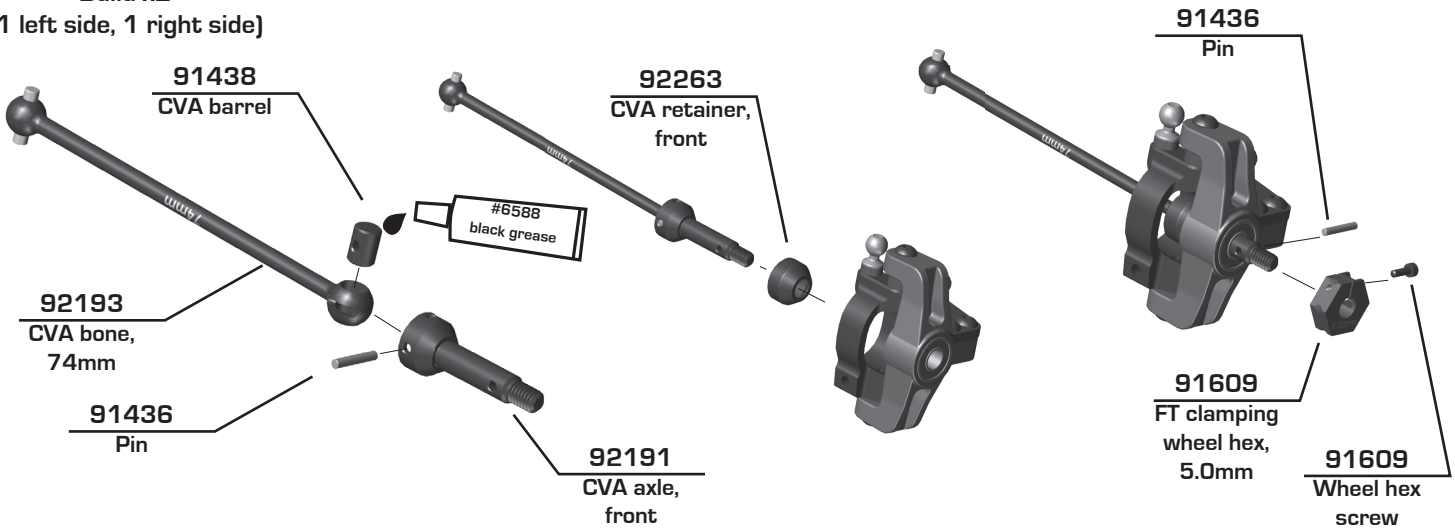

**:: Bag 7 - Step 3**

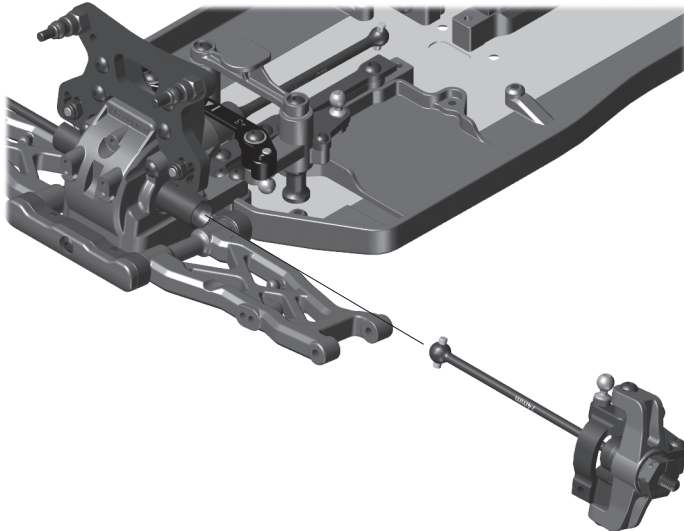

**!**  
Note, the groove in the hinge pin aligns with the set screw!

92187 3x30mm hinge pin, grooved

25225 M3x3mm set screw

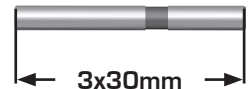

Bag 8 - Step 1

91047 6mm ballstud

#1596 thread lock

92180 Rear hub link mount

31383 2mm spacer

92267 Rear hub and insert (+1mm)

31383 x2 2mm spacer

89202 x2 M3x12mm BHCS

| Rear Axle Height |         |      |
|------------------|---------|------|
|                  | ↓ 0 3 ↑ | +3mm |
|                  | ↓ 1 2 ↑ | +2mm |
|                  | ↑ 1 2 ↓ | +1mm |
|                  | ↑ 0 3 ↓ | +0mm |

Bag 8 - Step 2

92299 CVA bone, 66mm

91438 CVA barrel

#6588 black grease

92207 CVA axle 66mm, rear

91436 Pin

91563 10x15x4mm bearing

91567 5x12x4mm bearing

91609 FT clamping wheel hex, 5.0mm

91609 Wheel hex screw

Build x2 (1 left side, 1 right side)

Clamping hex found in Tuning Parts Bag

Bag 8 - Step 3

Build x2 (1 left side, 1 right side)

92267 x2 Rear hub spacer

25215 M3 locknut

92188 Rear hub hinge pin

Do not overtighten after threads stop

Bag 9 - Step 1

It is important that the turnbuckle eyelets move freely once snapped on to the ballstud. If the fit is too tight, the car handling will be inconsistent. To check, grab turnbuckle eyelet with fingers and rotate the cup. If there is resistance, lightly squeeze ball cup with needle nose pliers as shown and test again. It is important that the ball cup be snapped onto the ballstud before squeezing with needle nose pliers. Be sure to check and adjust the fit for each ball cup that is installed.

**:: Bag 9 - Step 2**

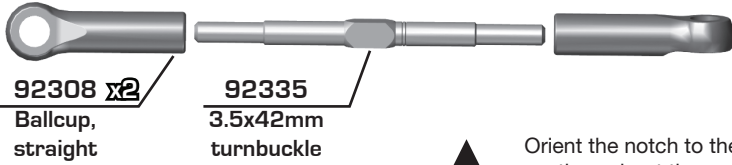

**!** Orient the notch to the left throughout the car. It indicates which end has the left hand threads!

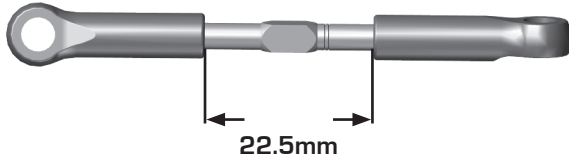

Build x2 (1 left side, 1 right side)

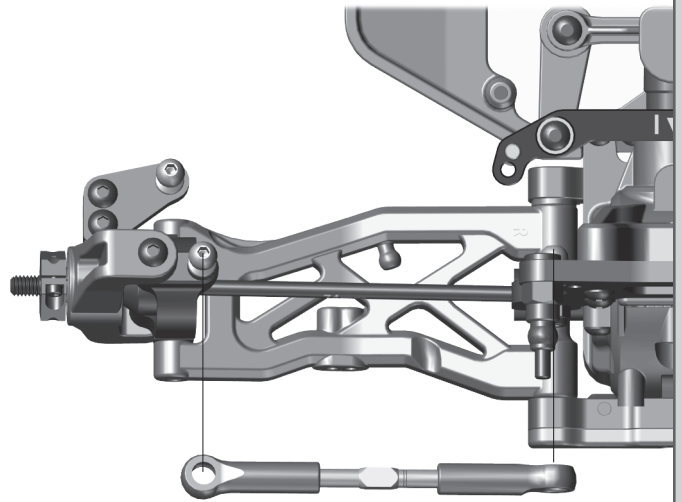

**:: Bag 9 - Step 3**

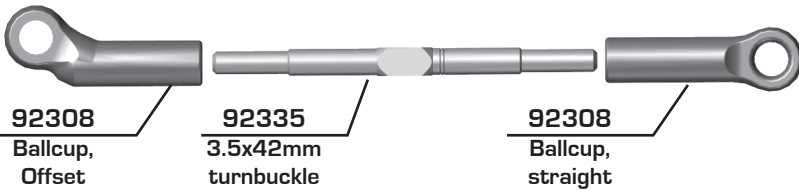

**!** Orient the notch to the left throughout the car. It indicates which end has the left hand threads!

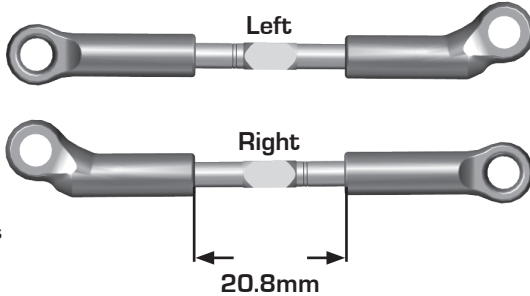

**!** There is two offset ballcups labeled "1" and "2". The ballcup labeled "1" goes on the left side of the car.

Build x2 (1 left side, 1 right side)

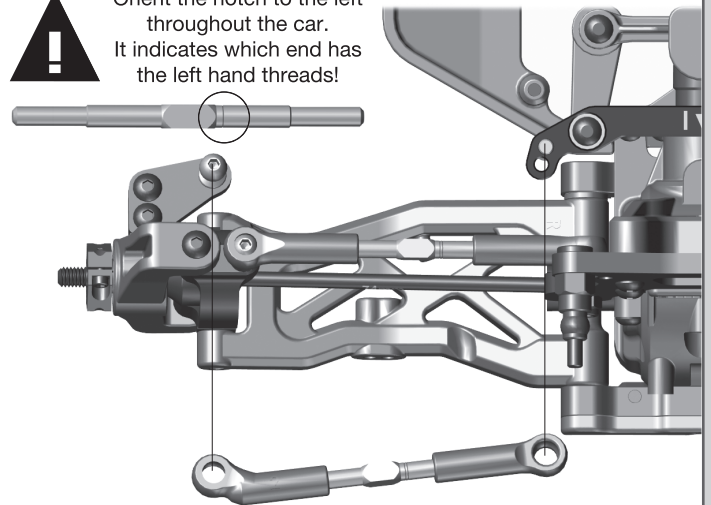

**:: Bag 9 - Step 4**

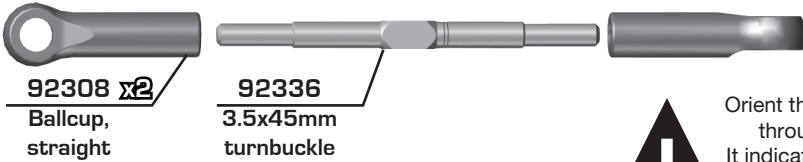

**!** Orient the notch to the left throughout the car. It indicates which end has the left hand threads!



Build x2 (1 left side, 1 right side)

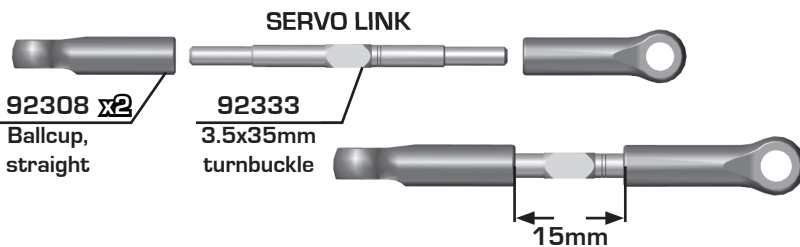

**!** Set this aside for installation when you install the servo!

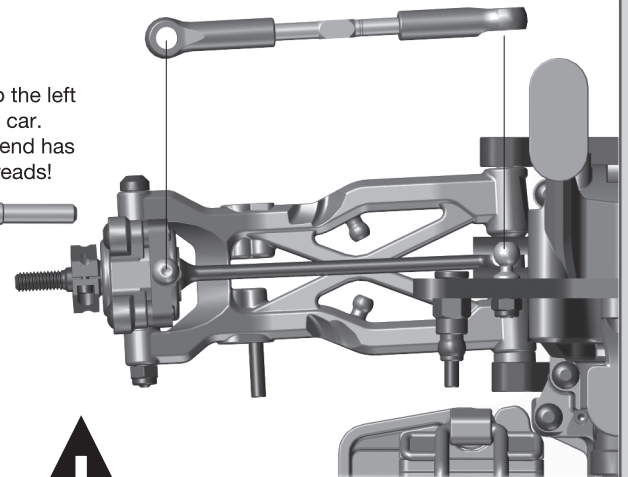

Bag 10 - Step 1

92292 Diff pin

92306 Diff sun gear, LTC

92306 5x8x0.2mm shim

92145 Diff case, center

#6588 black grease

92147 Diff outdrive, center

92133 Diff o-ring

92292 Diff pin

92306 Diff sun gear, LTC

92306 5x8x0.2mm shim

92146 Diff cap, center

#6588 black grease

92147 Diff outdrive, center

92133 Diff o-ring

92138 x2 Diff cross pin

92306 x4 Diff planet gear, LTC

92306 x4 2.55x6.0x0.15 shim

Diff fluid #5495 200k

Fill diffs to this level

Bag 10 - Step 2

It is important that the correct amount of fluid is added to the diff. Too much fluid may cause the diff to fail. Fill diffs to the reference line shown below. A more accurate method is to use a digital scale (AE#1522) to make sure the correct amount of fluid is added on the first build, and subsequent rebuilds. The entire diff assembly should weigh **43.75g** when built. Start by placing the ring gear assembly, screws, and cup assembly (without fluid) onto the scale. Then slowly add fluid to the cup assembly until the overall mass is **43.75g**.

| B74 Diff Weights (minus bearings) | Weight (grams) |         |
|-----------------------------------|----------------|---------|
|                                   | Metal          | Plastic |
| F/R Differential                  | 45.25          | 36      |
| Center Differential               | 43.75          | 34.5    |

91563 10x15x4mm bearing

31472 x4 2.5x8mm FHCS

92133 Diff gasket

91563 10x15x4mm bearing

31532 x4 3x8mm BHCS

92149 Spur gear, 48P, 78T

Spur gear direction has a cutout to fit over the diff housing

Bag 10 - Step 3

92235 Motor mount

92237 Center bulkhead

#1596 thread lock

25201 x4 3x8mm FHCS

25187 x2 M3x14mm BHCS

#1596 thread lock

31532 x2 M3x8mm BHCS

92238 Center bulkhead brace

Fan not included

25211 x2 M3x10mm BHCS

92312 Fan mount, upper

Install the front bone first. When assembled users need to shift the steering linkage to clear the ballcup

Upper fan mount optional. If not used, x2 M3x8mm BHCS are included for use on the top plate



Bag 11 - Step 1

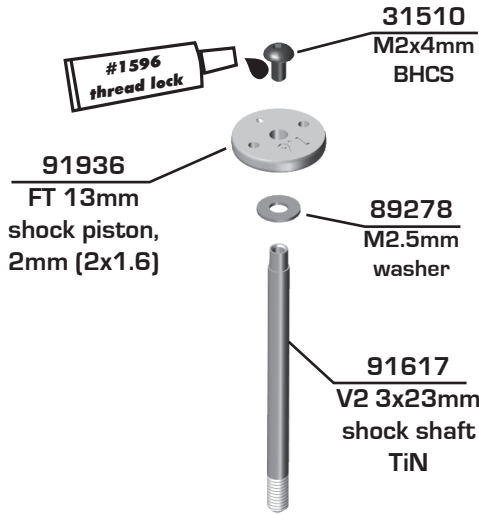

Build x2 front shocks

**!**  
Mount the shock pistons with the number facing up!



Racers Tip:

Use a marker over the numbers on the pistons to make them easily visible!

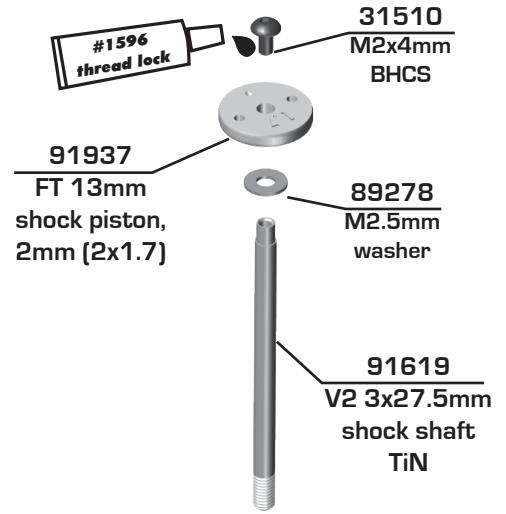

Build x2 rear shocks

Bag 11 - Step 2

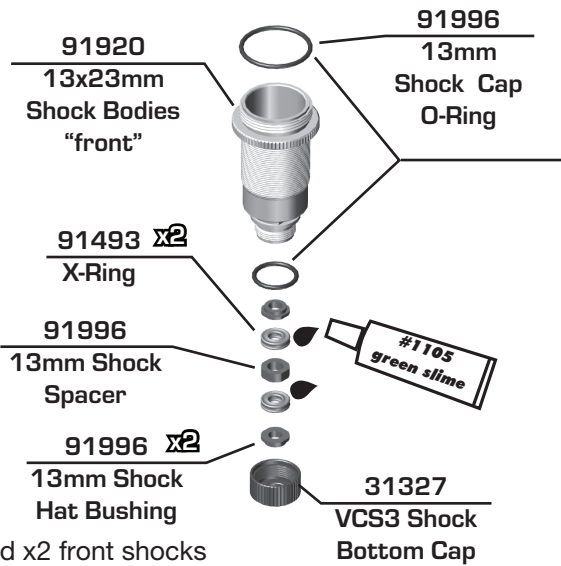

Build x2 front shocks

**!**  
Lightly rub shock oil on the O-ring before installation!



Racers Tip:

Coating the O-rings with green slime (#1105) helps seal & reduce O-ring swell! Green slime not included in kit!

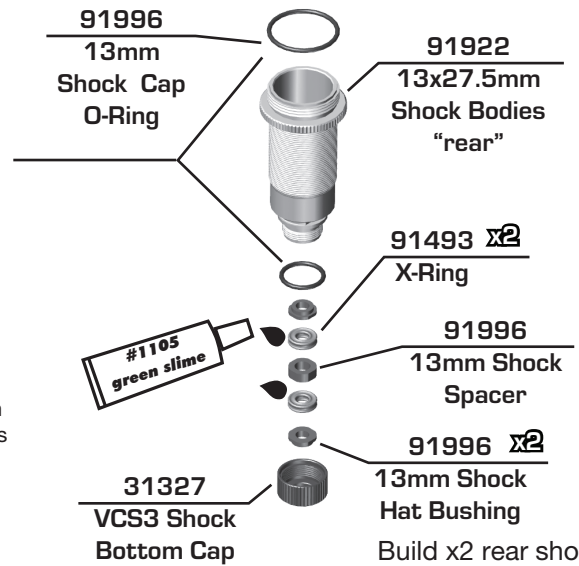

Build x2 rear shocks

Bag 11 - Step 3

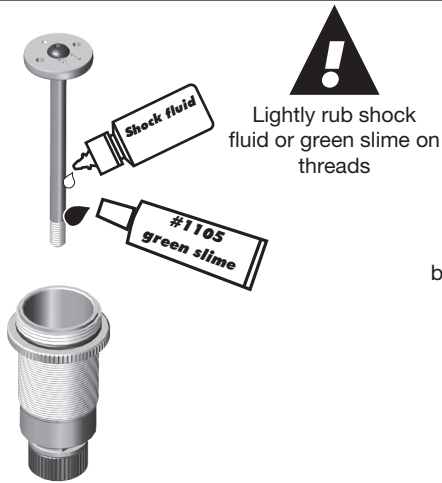

**!**  
There are 3 lengths of shock eyelet in the kit. Pay attention to length when building as these affect your droop and uptravel.

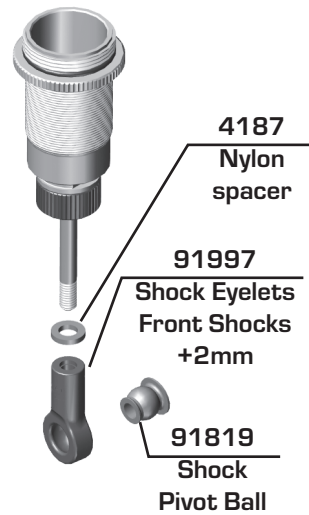
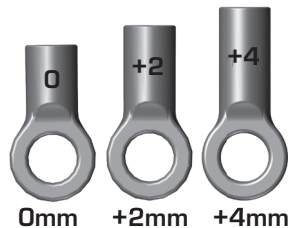

Build x2 front shocks

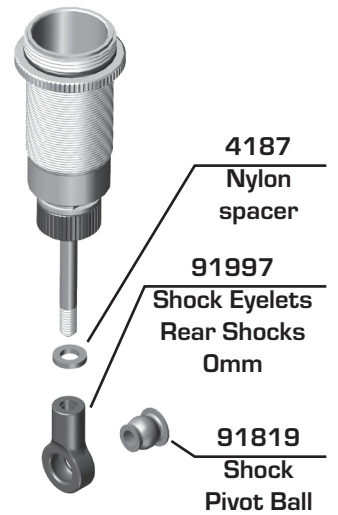

Build x2 rear shocks



**:: Bag 11 - Step 4**

**Shock Fluids:**  
Front Shock: 30wt  
Rear Shock: 30wt

**Steps 2-3    Steps 4-5    Steps 6-7    Step 8**

**Shock Bleeding Steps:**

1. Before assembly, get each bleed screw and thread it 1-2 turns into the shock cap, then remove the screw. This will make it easier when you are bleeding your shocks.
2. Pull shock shaft down.
3. Fill shock body 3/4 full with silicone shock fluid.
4. Slowly move the shock shaft up and down to remove air from under the piston.
5. Wait for bubbles to come to surface.
6. Fill shock body to top with silicone shock fluid.
7. Place a drop of oil in the cap and on cap threads.
8. Install cap (without bleed screw) and tighten completely.
9. Slowly compress shaft all the way to bleed excess silicone shock fluid out the hole in the cap (use rag around shock to catch excess fluid).
10. Install M2x4mm button head screw until snug while shaft is fully compressed.

**91926**  
13mm Shock Cap

**31510**  
2x4mm BHCS

**Stroke**  
Front: 22mm  
Rear: 28.5mm

**Steps 9-10**

**:: Bag 11 - Step 5**

**91996** x4  
13mm Threaded Collar O-ring

**91928** x4  
13mm Threaded Collar

**91943**  
13mm Front Spring, Yellow (3.80lb)

**91950**  
13mm Rear Spring, Blue (2.20lb)

**Racers Tip:**  
Use your finger to rub shock fluid on the O-ring for smoother adjustment!

Build x4

**:: Bag 11 - Step 6**

**91926**  
13mm Shock Spring Cup "Front - 9mm"

**Front: 6mm**  
**Rear: 6mm**

**#91926 13mm Shock Spring Cups**

0mm      5mm      9mm

**91926**  
13mm Shock Spring Cup "Rear - 0mm"

**!** Hold shock mounting hardware until after anti-roll bar installation.

Build x2 front shocks

Build x2 rear shocks

## :: Bag 12 - Step 1

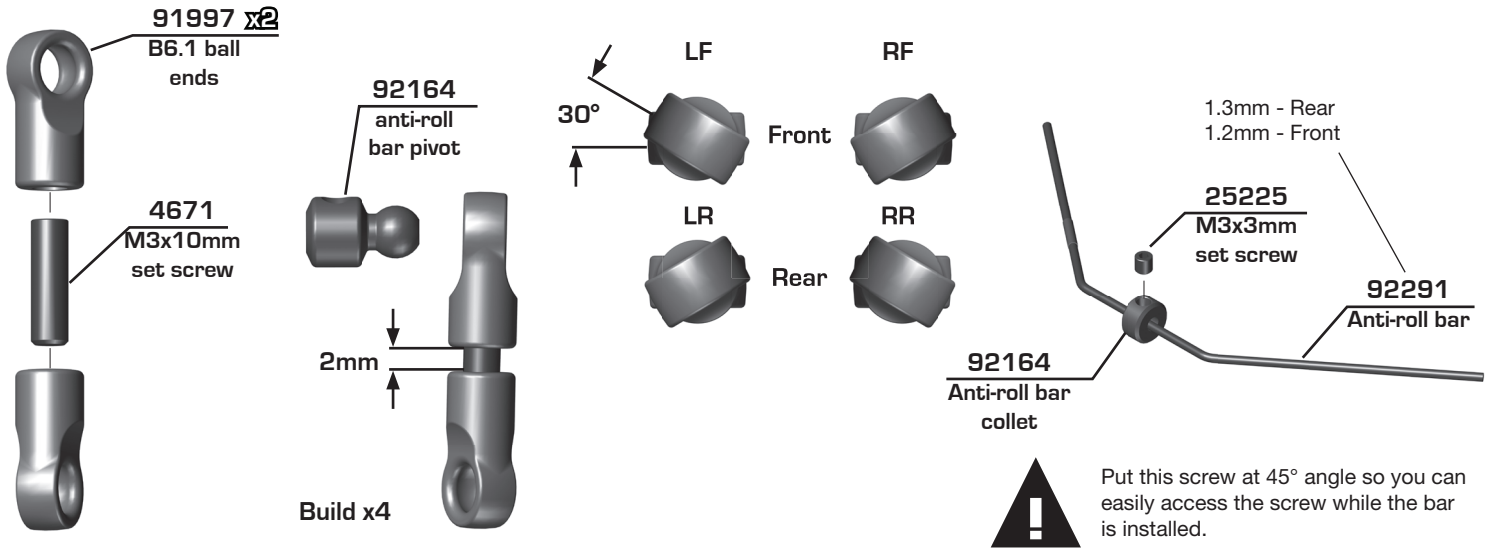

## :: Bag 12 - Step 2

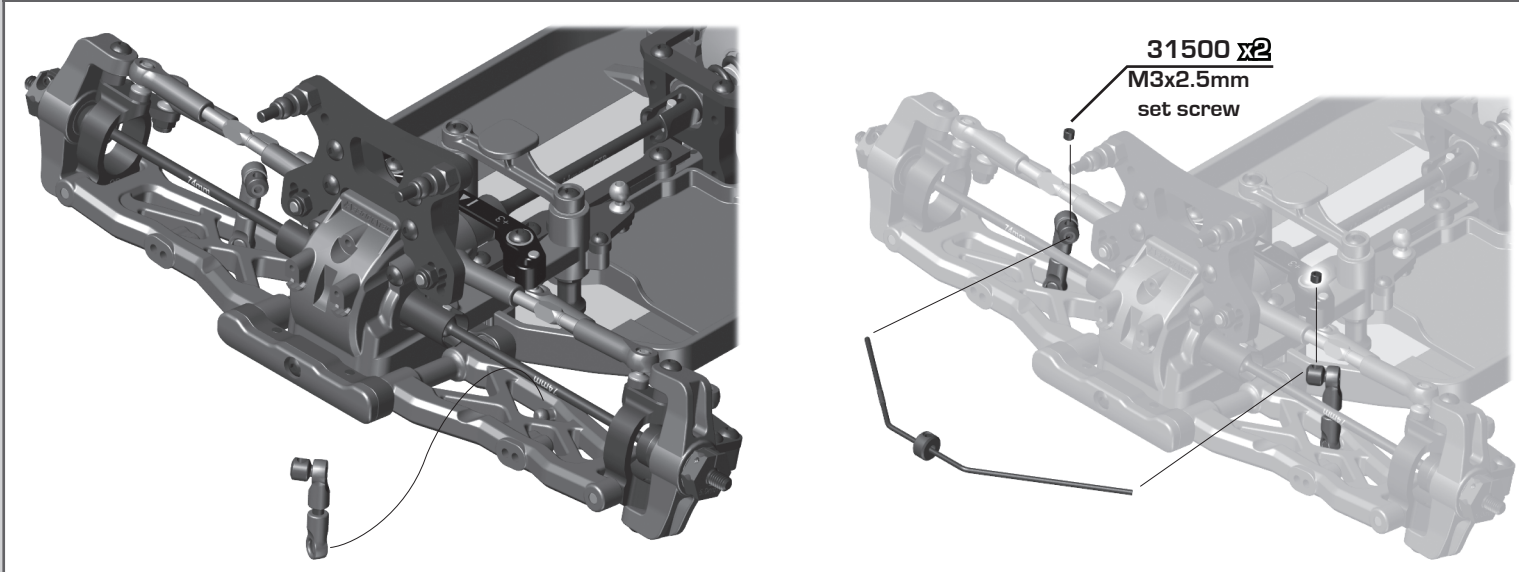

## :: Bag 12 - Step 3

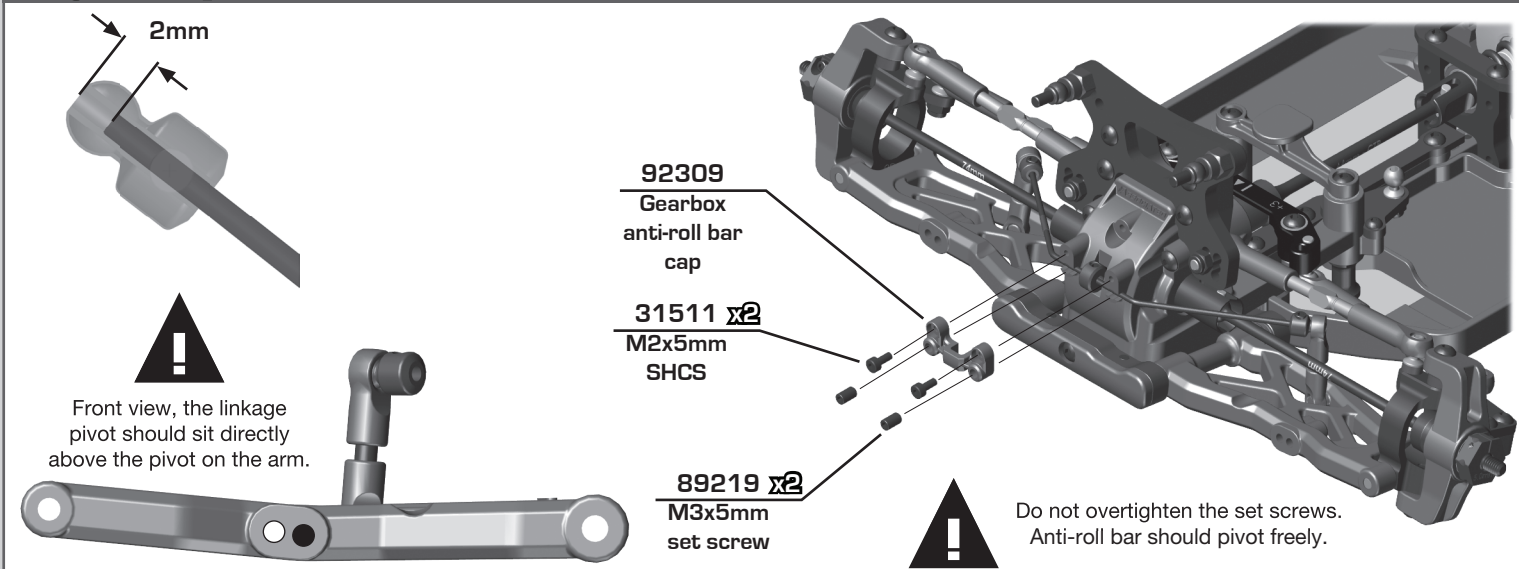

**:: Bag 12 - Step 4**

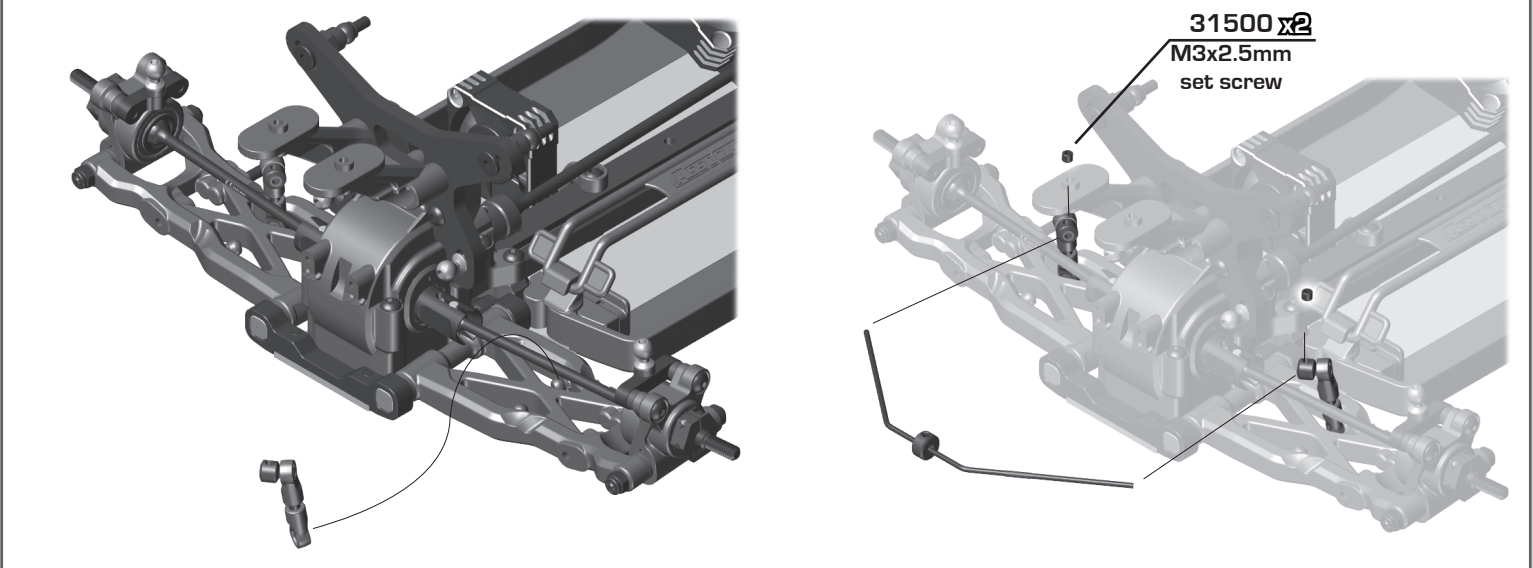

**:: Bag 12 - Step 5**

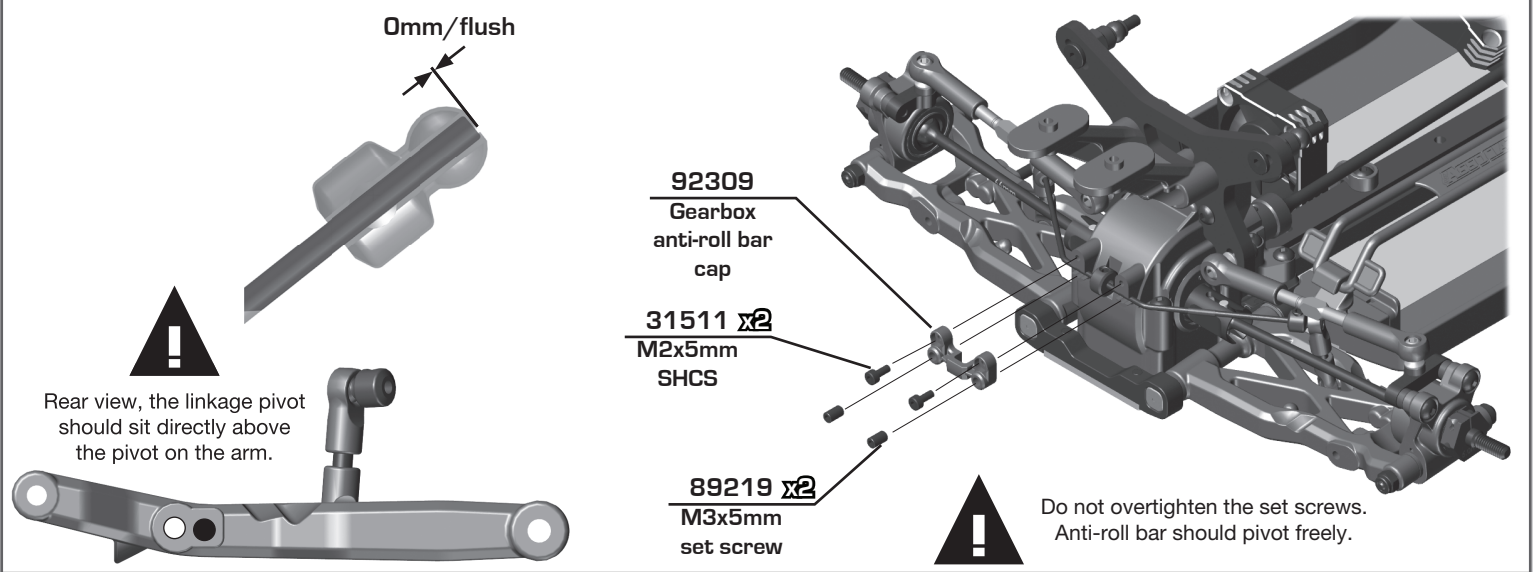

**:: Bag 13 - Step 1**

Install x2 front and x2 rear shocks

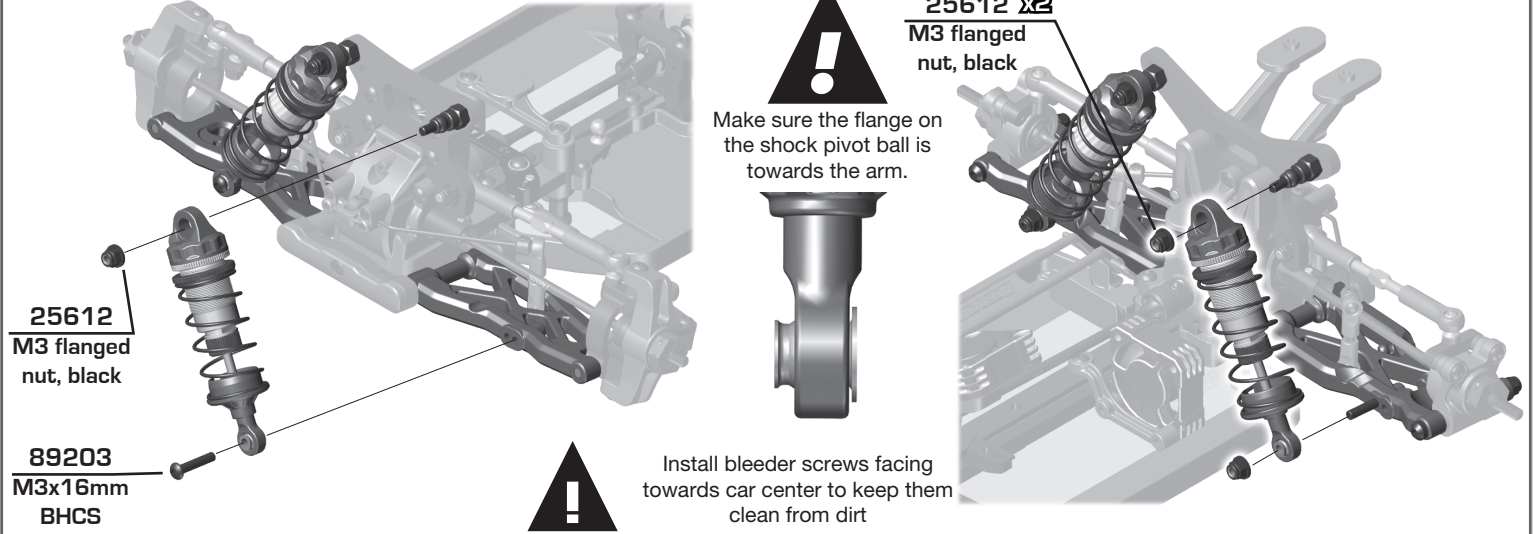



:: Bag 13 - Step 2

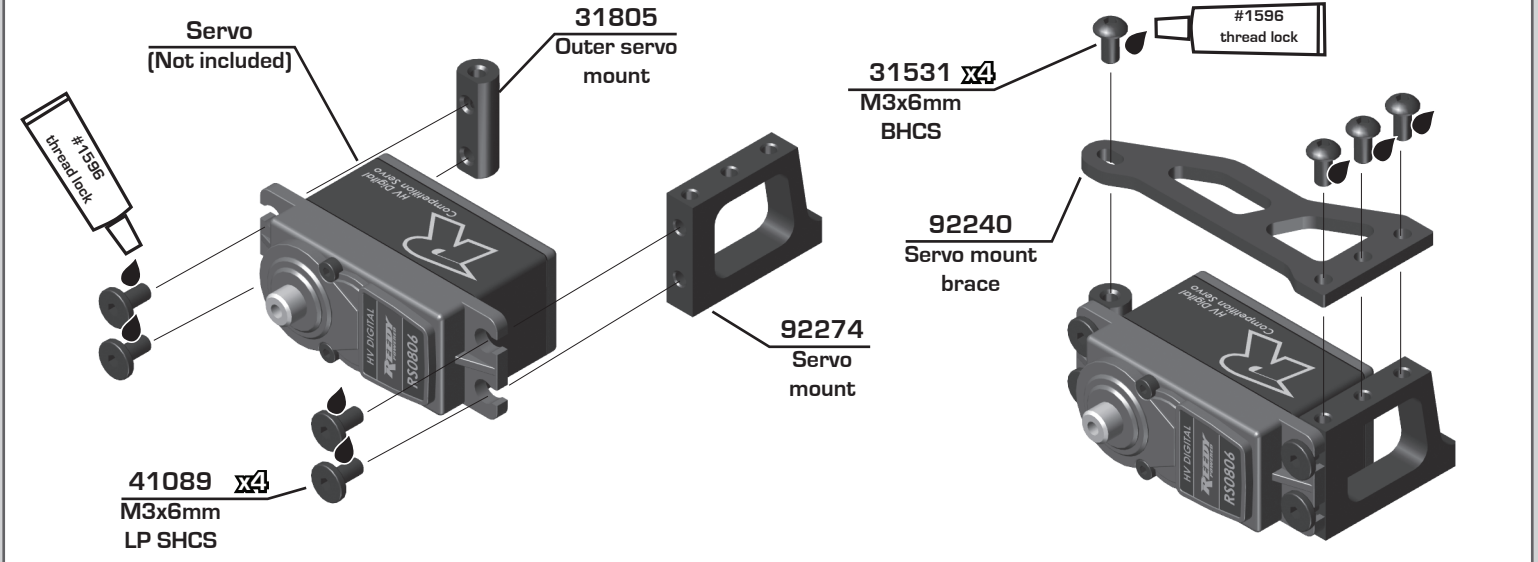

:: Bag 13 - Step 3

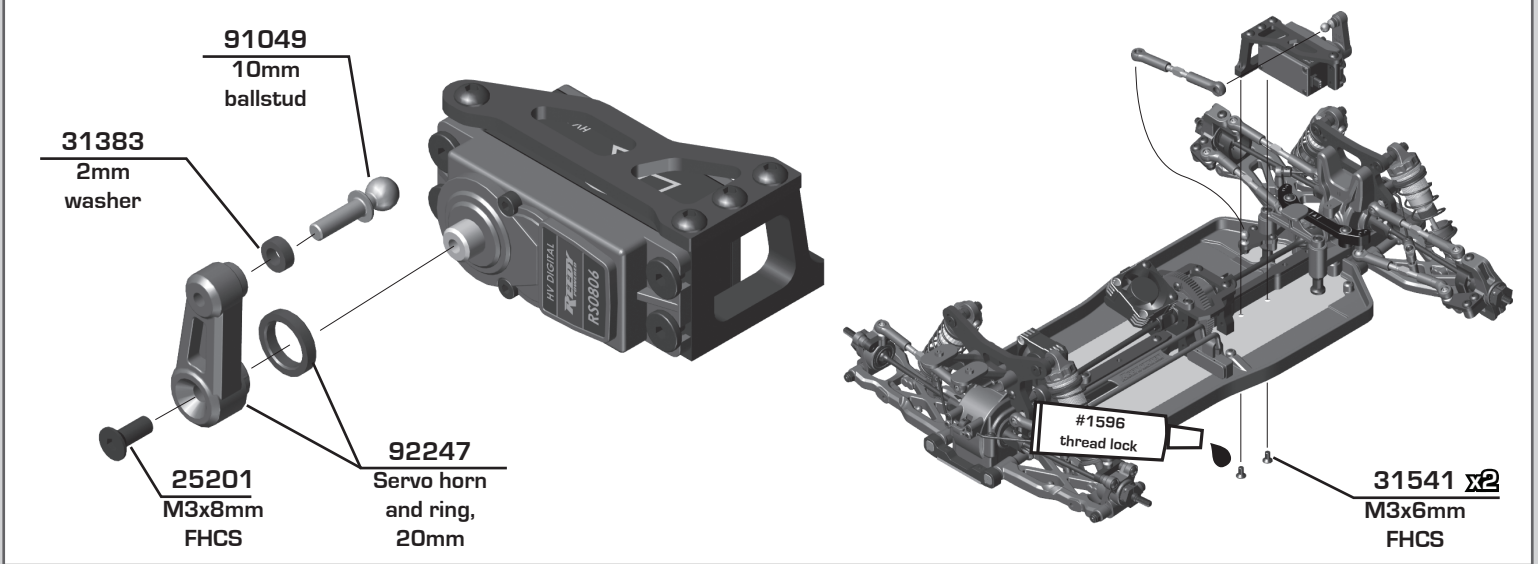

:: Bag 13 - Step 4

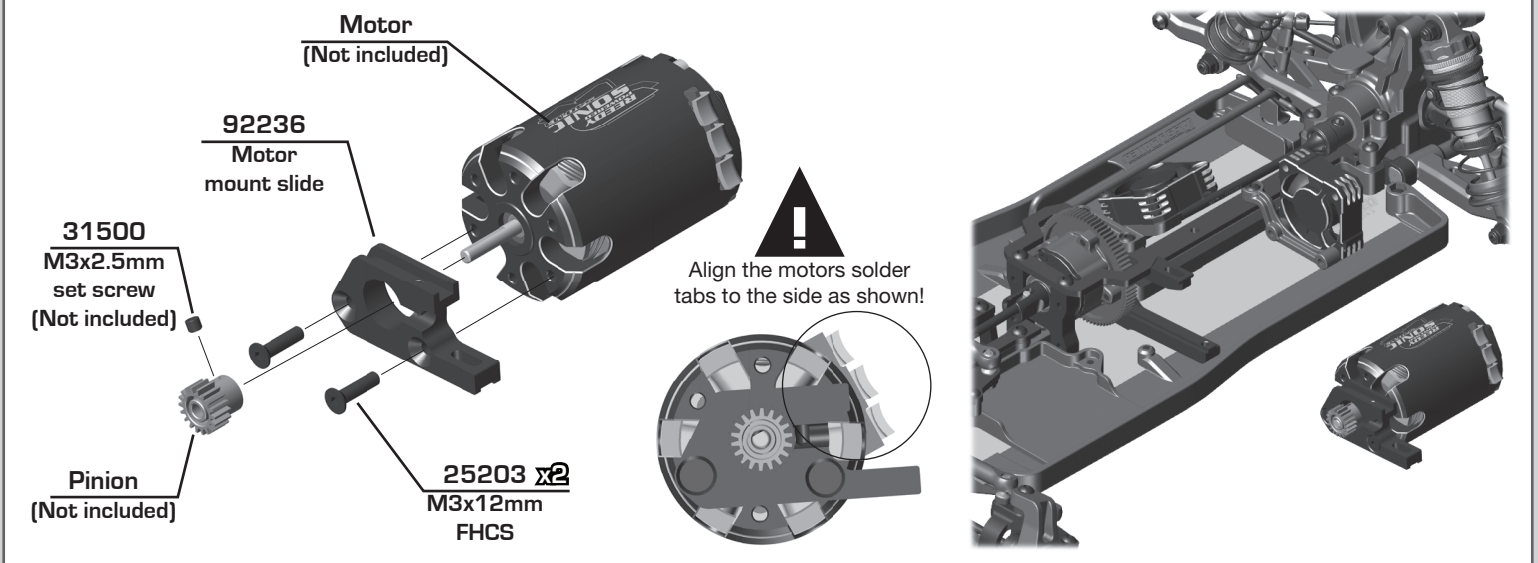

:: Bag 13 - Step 5

**41090 x2**  
M3x10mm  
LP SHCS

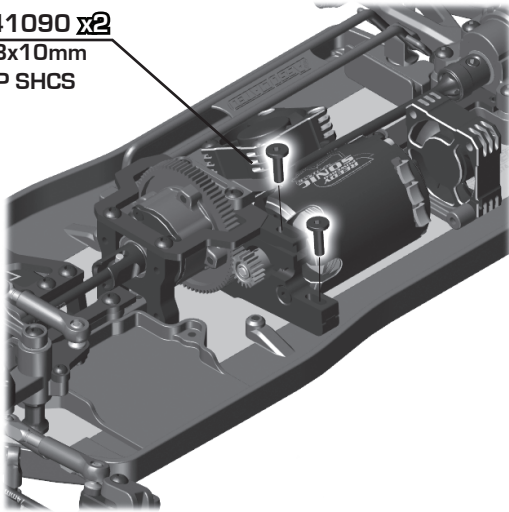

Receiver  
(Not included)

ESC  
(Not included)

**6727 x2**  
Servo tape

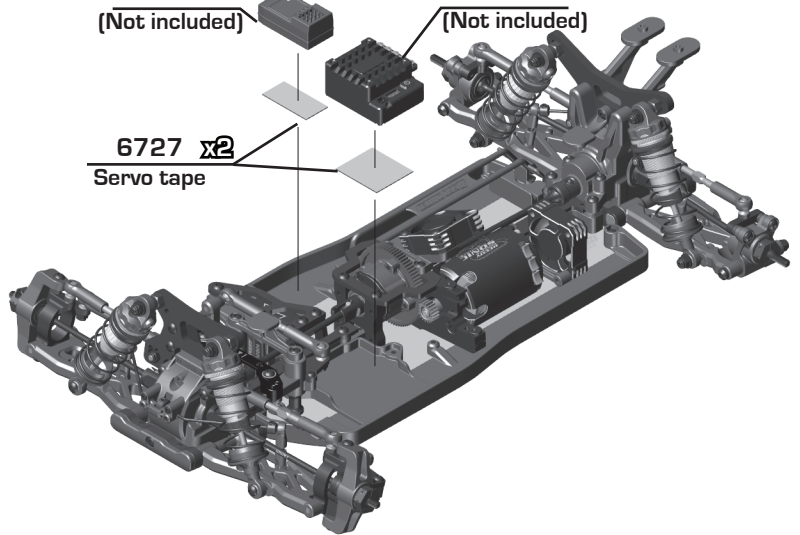

:: Bag 13 - Step 6

Battery  
(Not included)

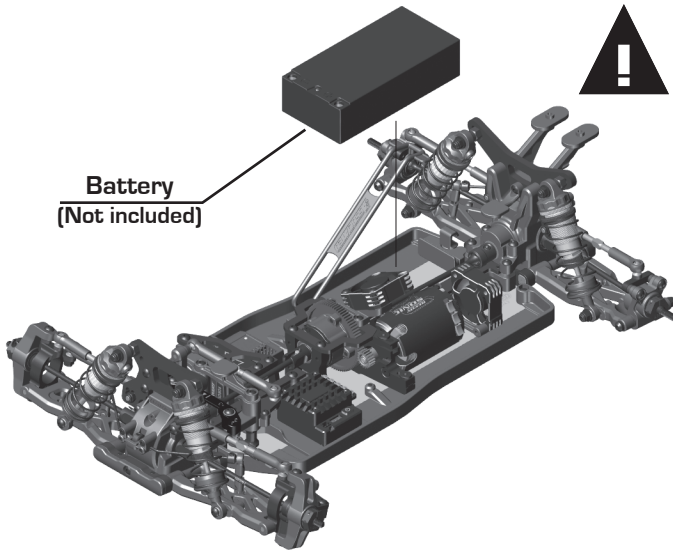

There are two cut line options on the rear wings.  
The lower one is for carpet setup, the higher one  
is for dirt setup.

Carpet  
cut line

Dirt  
cut line

**91741**  
B6 wing

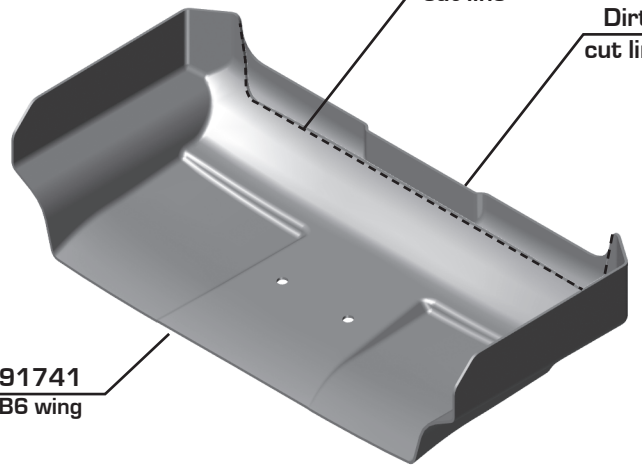

:: Bag 13 - Step 7

**25202 x2**  
M3x10mm  
FHCS

**92312 x2**  
B74 wing  
button

**92312**  
B74 wing  
angle shim

**92251**  
B74 body  
(light weight)

**92252**  
B74 front  
scoop

**31520**  
M2.5x6mm  
BHCS

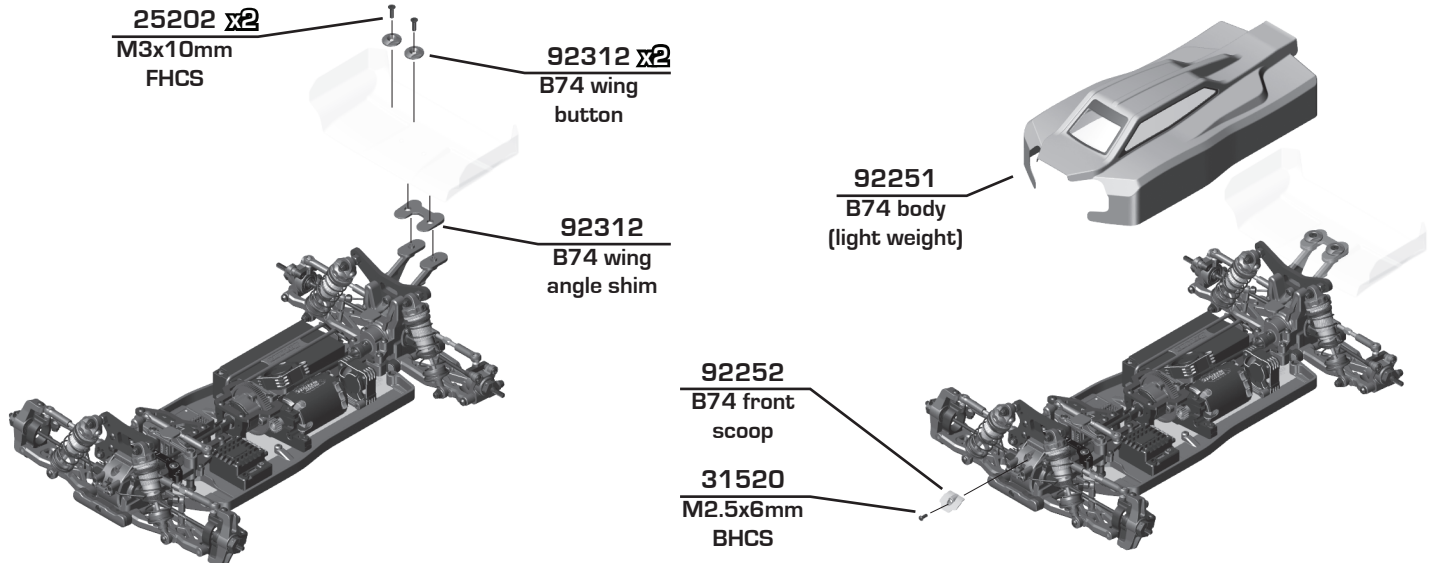



## :: Bag 13 - Step 8



Trim the body using the pictures below as your guides.

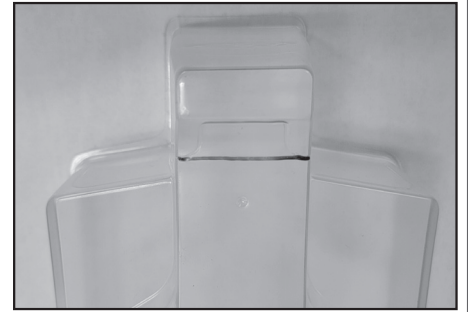
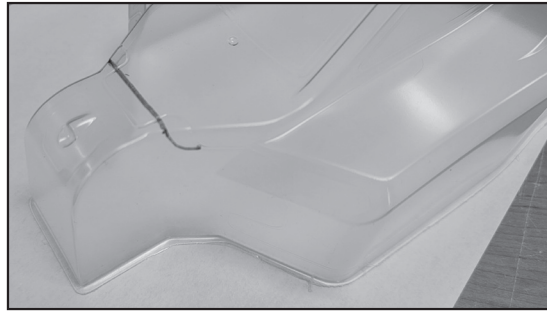

## :: Bag 13 - Step 9

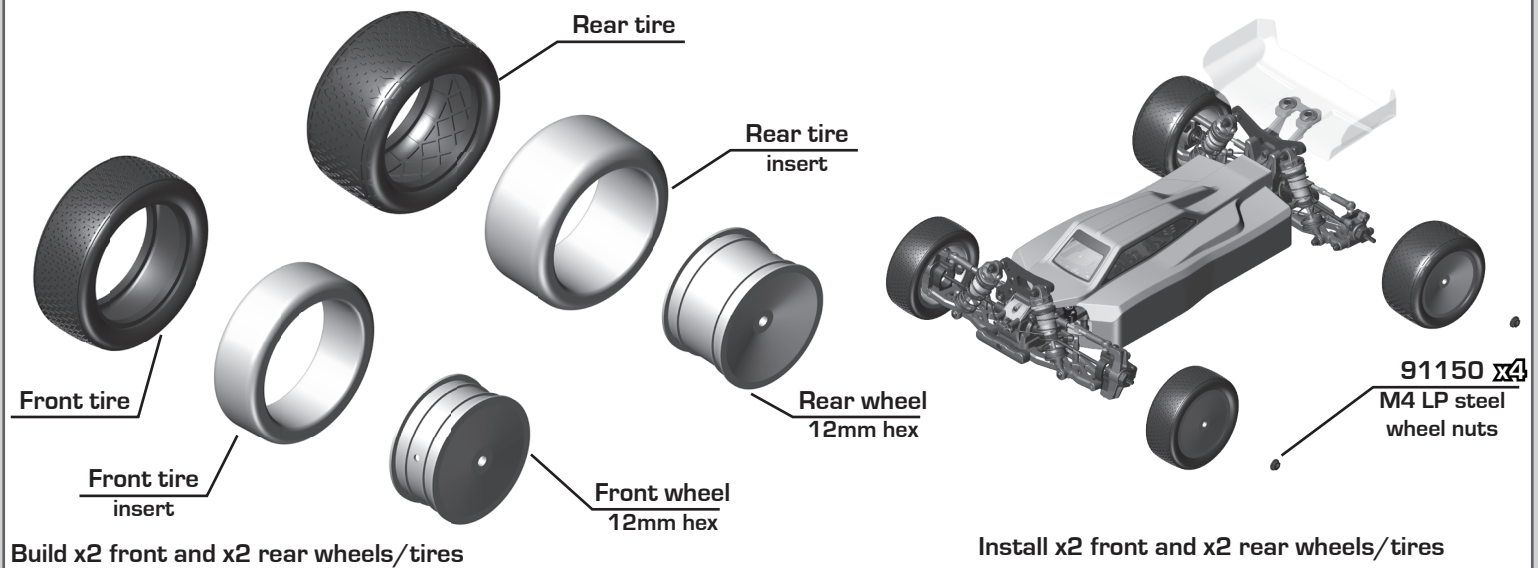

## :: Tuning Tips - Painting, Beginners

### Painting:

Your Kit requires a clear polycarbonate body. You will need to prep the body before you can paint it. Wash the **INSIDE** thoroughly with warm water and liquid detergent (do not use any detergents with scents or added hand lotion ingredients!). Dry the body using a clean, soft, lint-free cloth. Use the supplied window masks to cover the windows from the **INSIDE** of the body (RC bodies get painted on the inside). Using high quality masking tape, apply tape to the inside of the body to create a design. Spray (use either rattle can or airbrush) the paint on the inside of the body (preferably dark colors first, lighter colors last). **NOTE: ONLY** use paint that is recommended for (polycarbonate) plastics. If you do not, you can destroy the body! After the paint has completely dried (usually after 24 hours), cut the body along the trim lines. Make sure to drill or use a body reamer to make the holes for the antenna if needed! Use hook and loop tape to secure the body to the side rails of the vehicle.

### Tips for Beginners:

Before making any changes to the standard setup, make sure you can get around the track without crashing. Changes to your vehicle will not be beneficial if you can't stay on the track. Your goal is consistent laps. Once you can get around the track consistently, start tuning your vehicle. Make only **ONE** adjustment at a time, testing it before making another change. If the result of your adjustment is a faster lap, mark the change on the included setup sheet (make additional copies of the sheet before writing on it). If your adjustment results in a slower lap, revert back to the previous setup and try another change. When you are satisfied with your vehicle, fill in the setup sheet thoroughly and file it away. Use this as a guide for future track days or conditions. Periodically check all moving suspension parts. Suspension components must be kept clean and move freely without binding to prevent poor and/or inconsistent handling.

## :: Tuning Tips - Front Arm Mount Pill Insert Setups

### Standard Position

Use this position as a reference when changing pill locations.

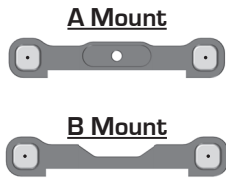

Kick-up: 8°  
Roll Center: +0  
Pin Width: +0

### Possible Insert Locations

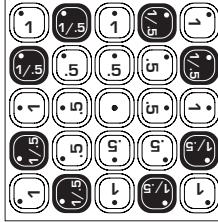

### Insert Hole Locations

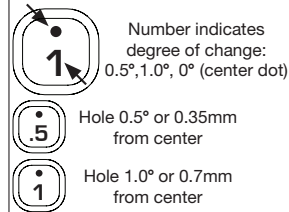

The aluminum front arm mounts utilize eccentric pill inserts to make fine adjustments to kick-up, pin height, and pin width. Adjustments can be made using the supplied inserts (#92014)

**Pin Width**  
More distance = wider pivot  
Less distance = narrower pivot

| A Mount | B Mount |          |
|---------|---------|----------|
|         |         | = +1.4mm |
|         |         | = +0.7mm |
|         |         | = 0mm    |
|         |         | = -0.7mm |
|         |         | = -1.4mm |

**Pin Height**  
Higher pin = Higher roll center  
Lower Pin = Lower roll center

| A Mount | B Mount |           |
|---------|---------|-----------|
|         |         | = +0.7mm  |
|         |         | = +0.35mm |
|         |         | = 0mm     |
|         |         | = -0.35mm |
|         |         | = -0.7mm  |

### Kick Up

More angle = More kick up  
Less angle = Less kick up

| A Mount | B Mount |       |
|---------|---------|-------|
|         |         | = 8°  |
|         |         | = 7°  |
|         |         | = 6°  |
|         |         | = 9°  |
|         |         | = 8°  |
|         |         | = 7°  |
|         |         | = 10° |
|         |         | = 9°  |
|         |         | = 8°  |

### Total Caster Angle

Total caster angle is the sum of the kick up angle and the caster block angle.

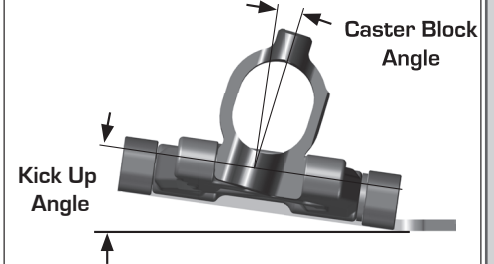

| Caster Block Angle | Kick Up Angle |     |     |     |     |
|--------------------|---------------|-----|-----|-----|-----|
|                    | 6°            | 7°  | 8°  | 9°  | 10° |
| 8°                 | 14°           | 15° | 16° | 17° | 18° |
| 9°                 | 15°           | 16° | 17° | 18° | 19° |
| 10°                | 16°           | 17° | 18° | 19° | 20° |

## :: Tuning Tips - Rear Arm Mount Pill Insert Setups

### Standard Position

Use this position as a reference when changing pill locations.

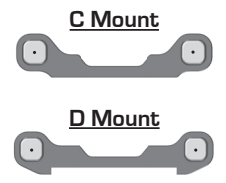

Toe: 3°  
Anti-Squat: 2°  
Roll Center: +0  
Pin Width: +0

### Possible Insert Locations

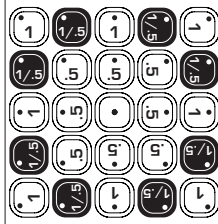

### Insert Hole Locations

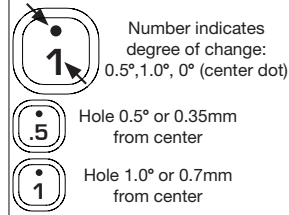

The aluminum front arm mounts utilize eccentric pill inserts to make fine adjustments to kick-up, pin height, and pin width. Adjustments can be made using the supplied inserts (#92014)

**Pin Width**  
More distance = wider pivot  
Less distance = narrower pivot

| C Mount | D Mount |          |
|---------|---------|----------|
|         |         | = +1.4mm |
|         |         | = +0.7mm |
|         |         | = 0mm    |
|         |         | = -0.7mm |
|         |         | = -1.4mm |

**Pin Height**  
Higher pin = Higher roll center  
Lower Pin = Lower roll center

| C Mount | D Mount |           |
|---------|---------|-----------|
|         |         | = +0.7mm  |
|         |         | = +0.35mm |
|         |         | = 0mm     |
|         |         | = -0.35mm |
|         |         | = -0.7mm  |

### Anti-Squat Angle

More angle = More anti-squat  
Less angle = Less anti-squat

| C Mount | D Mount |      |
|---------|---------|------|
|         |         | = 2° |
|         |         | = 1° |
|         |         | = 0° |
|         |         | = 3° |
|         |         | = 2° |
|         |         | = 1° |
|         |         | = 4° |
|         |         | = 3° |
|         |         | = 2° |

### Toe Angle

More angle = More toe in  
Less angle = Less toe in  
Shown in 1° changes

| C Mount | D Mount |      |
|---------|---------|------|
|         |         | = 3° |
|         |         | = 4° |
|         |         | = 5° |
|         |         | = 2° |
|         |         | = 3° |
|         |         | = 4° |
|         |         | = 1° |
|         |         | = 2° |
|         |         | = 3° |

### Front Suspension:

|                        |   |
|------------------------|---|
| Ride Height:           | 18mm  |
| Camber:                | -1deg   |
| Toe:                   | 1deg  |
| Anti-Roll Bar:         | 1.2mm   |
| Arm Type:              | Gull Wing - Standard  |
| Tower Type:            | Gull Wing   |
| Wheelbase Shim:        | 1mm behind arm  |
| Wheel Hex:             | 5.0mm   |
| Caster Block:          | 8° <input type="checkbox"/> 9° <input checked="" type="checkbox"/> 10° <input type="checkbox"/> |
| Chassis Brace Support: | 2mm G10   |
| Top Plate Brace:       | None  |
| Front Axles:           | CVA <input checked="" type="checkbox"/> DCV <input type="checkbox"/>                            |
| Notes:                 | _____   |

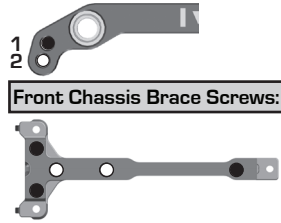

Front Chassis Brace Screws:

Ball Stud Spacing: 3mm

Arm Mount A: 1°  0.5°   
 Gray  Black



Arm Mount B: 1°  0.5°   
 Gray  Black



Diff Height:  
 +2   
 +0

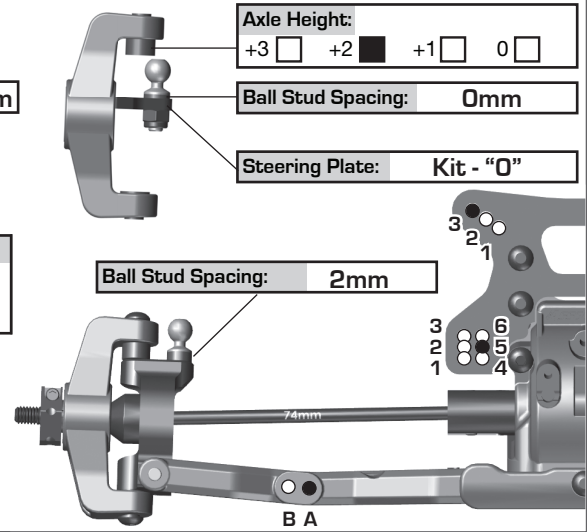

### Rear Suspension:

|                        |  |
|------------------------|--|
| Ride Height:           | 18mm   |
| Camber:                | -1deg  |
| Anti-Roll Bar:         | 1.3mm  |
| Arm Type:              | Standard   |
| Wheelbase Shim:        | 2mm behind arm   |
| Wheel Hex:             | 5.0mm  |
| Chassis Brace Support: | 2mm G10  |
| Hub Spacing:           | Fwd <input type="checkbox"/> Mid <input checked="" type="checkbox"/> Back <input type="checkbox"/> |
| Notes:                 | _____  |

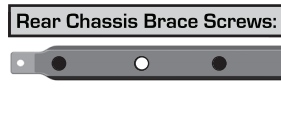

Rear Chassis Brace Screws:

Arm Mount C: 1°  0.5°   
 Gray  Black



Arm Mount D: 1°  0.5°   
 Gray  Black

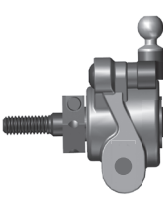

Axle Height:  
 0  3  +3  
 1  2  +2  
 1  2  +1  
 0  3  +0

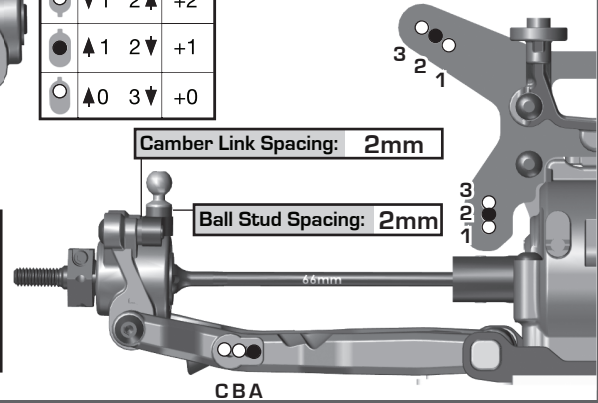

### Electronics:

|   |           |
|---|-----------|
| Radio:  | Servo:    |
| EPA: Throttle: %  | Brake: %  |
| ESC:  |           |
| ESC Settings:   |           |
| Motor / Wind:   | Timing:   |
| Pinion:   | Spur: 78T |
| Battery:  |           |
| Battery Position:   |           |
| Back 1 <input type="checkbox"/> 2 <input type="checkbox"/> 3 <input checked="" type="checkbox"/> 4 <input type="checkbox"/> | Forward   |
| Battery Weight:   |           |

### Differential:

|        | Front | Center | Rear  |
|--------|-------|--------|-------|
| Fluid: | 10K   | 200K   | 10K   |
| Gears: | Metal | Metal  | Metal |
| Type:  | LTC   | LTC    | LTC   |
| Notes: | _____ |        |       |

### Slipper Clutch:

|            |       |
|------------|-------|
| Type:      | _____ |
| # of Pads: | _____ |
| Setting:   | _____ |

### Shocks:

|                | Front             | Rear              |
|----------------|-------------------|-------------------|
| Piston:        | 2x1.6             | 2x1.7             |
| Thickness:     | 2mm               | 2mm               |
| Fluid:         | 30wt              | 30wt              |
| Spring:        | Yellow            | Blue              |
| Limiters:      | Int: ___ Ext: ___ | Int: ___ Ext: ___ |
| Stroke:        | 22mm              | 28.5mm            |
| Eyelet Length: | +2                | 0                 |
| Cup Offset:    | 9mm               | 0mm               |
| Notes:         | _____             |                   |



### Track Info:

|                   |  |
|-------------------|--|
| Size:             | Small <input type="checkbox"/> Medium <input type="checkbox"/> Large <input type="checkbox"/> Extra Large <input type="checkbox"/>   |
| Surface:          | Dirt <input type="checkbox"/> Carpet <input type="checkbox"/> Astroturf <input type="checkbox"/> Multi Surface <input type="checkbox"/>  |
| Traction:         | Low <input type="checkbox"/> Medium <input type="checkbox"/> High <input type="checkbox"/> Very High <input type="checkbox"/>  |
| Moisture:         | Dry <input type="checkbox"/> Damp <input type="checkbox"/> Wet <input type="checkbox"/>  |
| Condition:        | Indoor <input type="checkbox"/> Outdoor <input type="checkbox"/> Dusty <input type="checkbox"/> Hard Packed <input type="checkbox"/><br>Bumpy <input type="checkbox"/> Grooved <input type="checkbox"/> Smooth <input type="checkbox"/> Loamy <input type="checkbox"/> |
| Temperature:      | Ambient: _____ Track: _____  |
| Notes:            | _____  |
| Vehicle Comments: | _____  |

### Tires:



|                 |       |
|-----------------|-------|
| Front Tires:    | _____ |
| Front Compound: | _____ |
| Front Insert:   | _____ |
| Rear Tires:     | _____ |
| Rear Compound:  | _____ |
| Rear Insert:    | _____ |
| Wheel (F/R):    | _____ |
| Notes:          | _____ |

### Body, Wing, Weight:

|                       |   |
|-----------------------|---|
| Body:                 | Kit - Lightweight   |
| Front Wing:           | Yes <input type="checkbox"/> No <input checked="" type="checkbox"/> |
| Rear Wing:            | Kit   |
| Wing Angle:           | 0° <input type="checkbox"/> 6° <input checked="" type="checkbox"/>  |
| Wing Mount Height:    | 0 <input checked="" type="checkbox"/> -2 <input type="checkbox"/>   |
| Servo Weights:        | _____   |
| Electronic Weights:   | _____   |
| Total Vehicle Weight: | _____   |

## Front Suspension:

Ride Height: \_\_\_\_\_  
 Camber: \_\_\_\_\_  
 Toe: \_\_\_\_\_  
 Anti-Roll Bar: \_\_\_\_\_  
 Arm Type: \_\_\_\_\_  
 Tower Type: \_\_\_\_\_  
 Wheelbase Shim: \_\_\_\_\_  
 Wheel Hex: \_\_\_\_\_  
 Caster Block: 8°  9°  10°   
 Chassis Brace Support: \_\_\_\_\_  
 Top Plate Brace: \_\_\_\_\_  
 Front Axles: CVA  DCV   
 Notes: \_\_\_\_\_

1   
 2   
 Front Chassis Brace Screws: \_\_\_\_\_  
 Arm Mount A: 1°  0.5°   
 Gray  Black   
 Arm Mount B: 1°  0.5°   
 Gray  Black

Ball Stud Spacing: \_\_\_\_\_  
 Diff Height: +2   
 +0

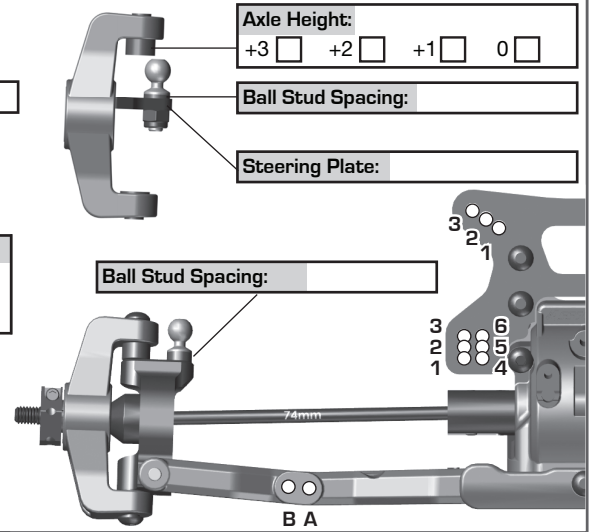

## Rear Suspension:

Ride Height: \_\_\_\_\_  
 Camber: \_\_\_\_\_  
 Anti-Roll Bar: \_\_\_\_\_  
 Arm Type: \_\_\_\_\_  
 Wheelbase Shim: \_\_\_\_\_  
 Wheel Hex: \_\_\_\_\_  
 Chassis Brace Support: \_\_\_\_\_  
 Hub Spacing: Fwd  Mid  Back   
 Notes: \_\_\_\_\_

Rear Chassis Brace Screws: \_\_\_\_\_  
 Arm Mount C: 1°  0.5°   
 Gray  Black   
 Arm Mount D: 1°  0.5°   
 Gray  Black

Diff Height: +3   
 +2   
 +1   
 +0

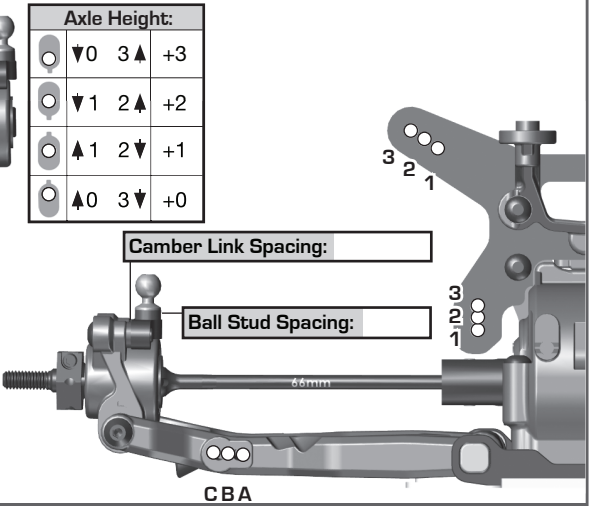

## Electronics:

Radio: \_\_\_\_\_ Servo: \_\_\_\_\_  
 EPA: Throttle: \_\_\_\_\_ % Brake: \_\_\_\_\_ %  
 ESC: \_\_\_\_\_  
 ESC Settings: \_\_\_\_\_  
 Motor / Wind: \_\_\_\_\_ Timing: \_\_\_\_\_  
 Pinion: \_\_\_\_\_ Spur: \_\_\_\_\_  
 Battery: \_\_\_\_\_  
 Battery Position: Back 1  2  3  4  Forward  
 Battery Weight: \_\_\_\_\_

## Differential:

|        | Front | Center | Rear |
|--------|-------|--------|------|
| Fluid: |       |        |      |
| Gears: |       |        |      |
| Type:  |       |        |      |
| Notes: | _____ |        |      |

Slipper Clutch: Type: \_\_\_\_\_  
 # of Pads: \_\_\_\_\_  
 Setting: \_\_\_\_\_

## Shocks:

|                | Front                 | Rear                  |
|----------------|-----------------------|-----------------------|
| Piston:        |                       |                       |
| Thickness:     |                       |                       |
| Fluid:         |                       |                       |
| Spring:        |                       |                       |
| Limiters:      | Int: _____ Ext: _____ | Int: _____ Ext: _____ |
| Stroke:        |                       |                       |
| Eyelet Length: |                       |                       |
| Cup Offset:    |                       |                       |
| Notes:         | _____                 |                       |

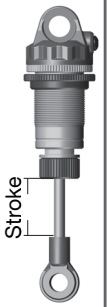

## Track Info:

Size: Small  Medium  Large  Extra Large   
 Surface: Dirt  Carpet  Astroturf  Multi Surface   
 Traction: Low  Medium  High  Very High   
 Moisture: Dry  Damp  Wet   
 Condition: Indoor  Outdoor  Dusty  Hard Packed   
 Bumpy  Grooved  Smooth  Loamy   
 Temperature: Ambient: \_\_\_\_\_ Track: \_\_\_\_\_  
 Notes: \_\_\_\_\_  
 Vehicle Comments: \_\_\_\_\_

## Tires:

Front Tires: \_\_\_\_\_  
 Front Compound: \_\_\_\_\_  
 Front Insert: \_\_\_\_\_  
 Rear Tires: \_\_\_\_\_  
 Rear Compound: \_\_\_\_\_  
 Rear Insert: \_\_\_\_\_  
 Wheel (F/R): \_\_\_\_\_  
 Notes: \_\_\_\_\_

## Body, Wing, Weight:

Body: \_\_\_\_\_  
 Front Wing: Yes  No   
 Rear Wing: \_\_\_\_\_  
 Wing Angle: 0°  6°   
 Wing Mount Height: 0  -2   
 Servo Weights: \_\_\_\_\_  
 Electronic Weights: \_\_\_\_\_  
 Total Vehicle Weight: \_\_\_\_\_



# FIND IT ON ASSOCIATEDELECTRICS.COM

## CARS & TRUCKS



### Vehicle Spare Parts GO TO:

AssociatedElectrics.com →  
Team Associated tab →  
Cars & Trucks →  
Scroll to your vehicle →  
Parts & Accessories link

## SETUP SHEETS & MANUALS



### Setups and Manuals GO TO:

AssociatedElectrics.com →  
Team Associated tab →  
Manuals & Setups →  
Scroll to your vehicle

## A-TEAM APPS



### Tuning Guides & Tips GO TO:

AssociatedElectrics.com →  
Support →  
A-Team Apps



**Associated Electrics, Inc.**

**21062 Bake Parkway Lake Forest, CA 92630 USA**

**call: (949) 544-7500 - fax: (949) 544-7501**

**Check out the following web sites for all of our kits, current products,  
new releases, setup help, tips, and racing info!**

**[www.AssociatedElectrics.com](http://www.AssociatedElectrics.com)**

## FOLLOW US ON SOCIAL MEDIA



**TeamAssociated  
ReedyPower  
ElementRC**

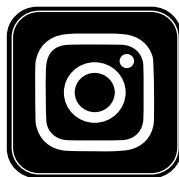

**@TeamAssociatedRC  
@ReedyPower  
@Element\_RC**



**@Team\_Associated  
@ReedyPower**