

## Front Suspension:

RESET

Ride Height:	12 mm
Camber:	-1*
Toe:	Tierod Gap = 19.6 mm
Anti-Roll Bar:	1.6 mm
Arm Type:	#92297 FT Carbon
Wheelbase Shim:	1 mm Behind Arm
Wheel Hex:	#91609 FT Clamping Hex, 5.0 mm
Caster Block:	8° <input type="checkbox"/> 9° <input checked="" type="checkbox"/> 10° <input type="checkbox"/>
Chassis Brace Support:	#92114 FT Carbon, 2.5 mm
Top Plate Brace:	Yes <input checked="" type="checkbox"/> No <input type="checkbox"/>
Front Axles:	CVA <input type="checkbox"/> DCV <input checked="" type="checkbox"/>
Notes:	#91994 13 x 23 mm Shock Kit #92300 RC10B74 FT Chassis Braces, Carbon

### Front Chassis Brace Screws:

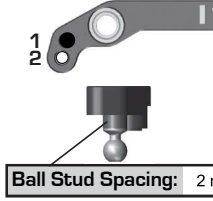

Axle Height:	+3 <input checked="" type="checkbox"/> +2 <input type="checkbox"/> +1 <input type="checkbox"/> 0 <input type="checkbox"/>
Ball Stud Spacing:	0 mm
Steering Plate:	#92272 Kit

Arm Mount A: 1°  0.5°



Arm Mount B: 1°  0.5°



Diff Height:

+3

+2

+1

0

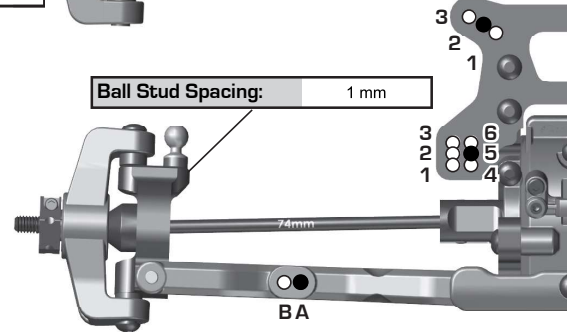

## Rear Suspension:

Ride Height:	12 mm
Camber:	-1*
Anti-Roll Bar:	1.8 mm
Arm Type:	#92298 FT Carbon
Wheelbase Shim:	2 mm In Front Of Arm
Wheel Hex:	#71034 FT Clamping Hex, 6.0 mm
CVA Bone Length:	#92212 66 mm
Chassis Brace Support:	#92115 FT Carbon, 2.5 mm
Hub Spacing:	Fwd <input type="checkbox"/> Mid <input checked="" type="checkbox"/> Back <input type="checkbox"/>
Notes:	#91995 13 x 27.5 mm Shock Kit #92113 RC10B74 Chassis Brace, Standard (Test Carbon) #92302 RC10B74.1 Rear Hubs, Carbon

### Rear Chassis Brace Screws:



Arm Mount C: 1°  0.5°



Arm Mount D: 1°  0.5°



Diff Height:

+3

+2

+1

0

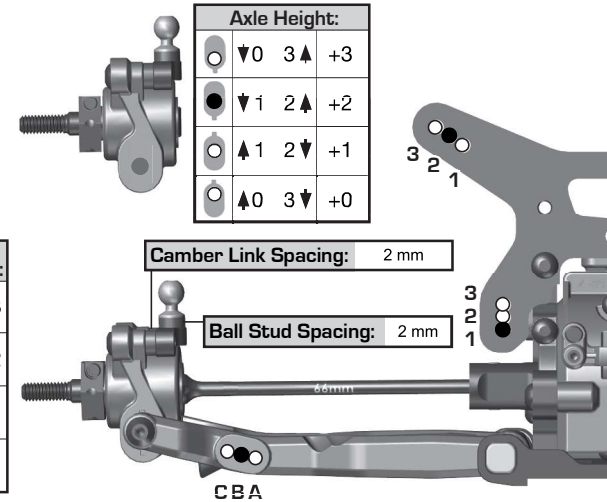

## Electronics:

Radio:	Futaba T10PX	Servo:	Savox SC-1267
EPA: Throttle:	100 %	Brake:	87 %
ESC:	Hobbywing XR10 G2 Pro		
ESC Settings:	N/A		
Motor:	Hobbywing (ProTek Aluminum Motor Fan)		
Wind:	4.5T	Timing:	30*
Pinion:	#1336 FT 18T	Spur:	#92295 Octalock 78T
Battery:	ProTek 4600 (Taped In)		
Battery Position:	BACK 1 <input type="checkbox"/> 2 <input type="checkbox"/> 3 <input type="checkbox"/> 4 <input checked="" type="checkbox"/> FWD		

## Differential:

Front Fluid:	#5447 FT 15K	Mass:	N/A
Gears:	Plastic <input type="checkbox"/> Metal <input checked="" type="checkbox"/>		
Center Fluid:	N/A	Mass:	N/A
Gears:	Plastic <input type="checkbox"/> Metal <input type="checkbox"/>		
Rear Fluid:	#5447 FT 15K	Mass:	N/A
Gears:	Plastic <input type="checkbox"/> Metal <input checked="" type="checkbox"/>		
Slipper Clutch:	Setting: Front Tires Just Lift Off Ground		
Pad Type:	2 Pads <input type="checkbox"/> 3 Pads <input checked="" type="checkbox"/>		

## Shocks:

	Front	Rear
Piston:	2 mm FT 2 x 1.6 + 1.1 Flat, Drilled	2 mm FT 2 x 1.8 + 1.1 Flat, Drilled
Fluid:	#5477 FT 42.5 wt	#5432 FT 32.5 wt
Spring:	#91946 Purple	#91950 Blue
Limiters:	0 In / 6 mm Out	0 In / 4 mm Out
Stroke:	23.5 mm (Limiters Not Included)	28.0 mm (Limiters Not Included)
Eyelet Length:	+0 mm	+0 mm
Cup Offset:	5 mm	0 mm
Notes:	#91494 FT Machined Shock Spacers; #91493 FT X-Rings	



## Track Info:

Size:	Small <input type="checkbox"/> Medium <input type="checkbox"/> Large <input type="checkbox"/> Extra Large <input checked="" type="checkbox"/>
Surface:	Dirt <input type="checkbox"/> Carpet <input type="checkbox"/> Astroturf <input checked="" type="checkbox"/> Multi Surface <input type="checkbox"/>
Traction:	Low <input type="checkbox"/> Medium <input type="checkbox"/> High <input type="checkbox"/> Very High <input type="checkbox"/>
Moisture:	Dry <input type="checkbox"/> Damp <input checked="" type="checkbox"/> Wet <input type="checkbox"/>
Condition:	Indoor <input checked="" type="checkbox"/> Outdoor <input type="checkbox"/> Dusty <input type="checkbox"/> Hard Packed <input type="checkbox"/> Bumpy <input type="checkbox"/> Grooved <input type="checkbox"/> Smooth <input type="checkbox"/> Loamy <input type="checkbox"/>
Temperature:	Ambient: 65F Track: 65F
Notes:	

## Tires:

Front Tires:	JConcepts Fuzz Bites
Front Compound:	Pink
Front Insert:	JConcepts Open Cell
Rear Tires:	JConcepts Nessi
Rear Compound:	Pink
Rear Insert:	JConcepts Open Cell
Wheel (F/R):	JConcepts Mono Wide Front / JConcepts Mono Rear
Notes:	Front Sidewalls Glued

## Body, Wing, Weight:

Body:	JConcepts S2
Wing:	JConcepts 7" Carpet
Front Wing:	Yes <input type="checkbox"/> No <input checked="" type="checkbox"/>
Wing Angle:	0° <input type="checkbox"/> 6° <input checked="" type="checkbox"/>
Weights:	
Total Vehicle Weight:	1630g

## Vehicle Comments:

Notes: #92301 FT Carbon Gearboxes; ProTek Carbon Fiber Side Guards;