

Front Suspension:

Reset Forms

| | |
|-------------------------------|---|
| Ride Height: | 15.5mm |
| Camber: | -2° |
| Toe: | +1.5° |
| Anti-Roll Bar: | None |
| Arm Type: | #92411 FT Carbon |
| Tower Type: | #92430 Kit |
| Wheel Hex: | #91683 FT Titanium Front Axle, 5mm |
| Steering Block KPI: | #92414 Standard - 4 Trail / KPI 3 |
| Caster Block Insert: | 0 <input type="checkbox"/> +2.5 <input type="checkbox"/> +5 <input type="checkbox"/> |
| Bulkhead Type: | #92437 FT +/- 2.5°, Aluminum |
| Kick-Up Angle: | -2.5 <input type="checkbox"/> 0 <input type="checkbox"/> +2.5 <input checked="" type="checkbox"/> |
| Steering Stop Spacing: | 1.5mm |
| Caster Block Spacing: | Fwd <input checked="" type="checkbox"/> Back <input type="checkbox"/> |
| Notes: | JConcepts Aluminum Steering Assembly (Rack Insert Up) |

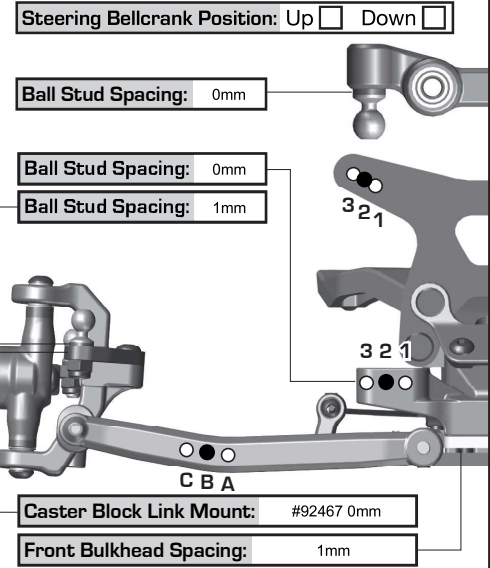
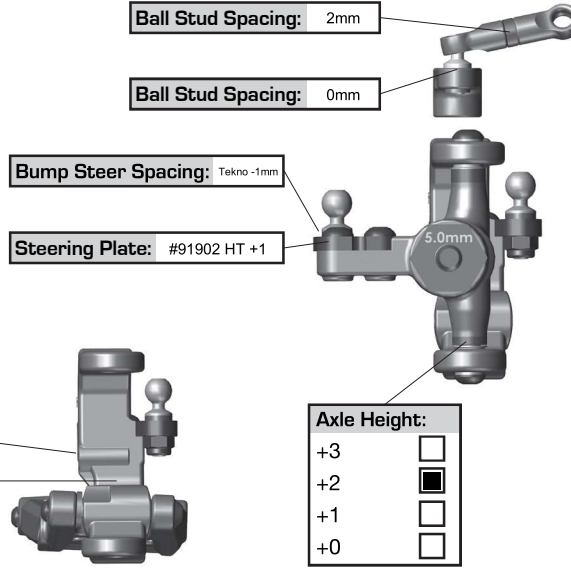

Rear Suspension:

| | |
|-----------------------|--|
| Ride Height: | 16mm |
| Camber: | -2° |
| Anti-Roll Bar: | None |
| Arm Type: | #92409 FT Carbon |
| Tower Type: | JConcepts -2 mm |
| Arm Spacing: | Fwd <input type="checkbox"/> Mid <input checked="" type="checkbox"/> Back <input type="checkbox"/> |
| Wheel Hex: | #71034 FT Clamping, 6.0mm |
| Hub Type: | Std <input type="checkbox"/> HRC <input checked="" type="checkbox"/> #92413 FT Carbon |
| Hub Spacing: | Fwd <input type="checkbox"/> Mid <input checked="" type="checkbox"/> Back <input type="checkbox"/> |
| Drive Shaft: | CVA's <input checked="" type="checkbox"/> Universals <input type="checkbox"/> |
| Notes: | #92185 FT Carbon Hub Link Shims #92477 FT Ballstud Mount, +2 mm |

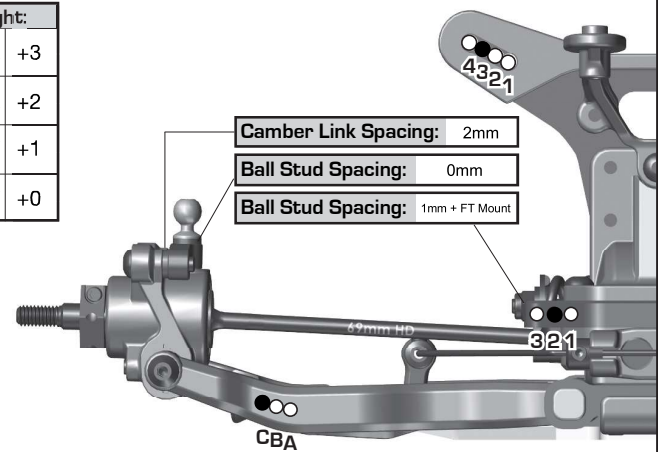
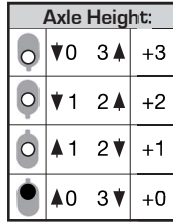
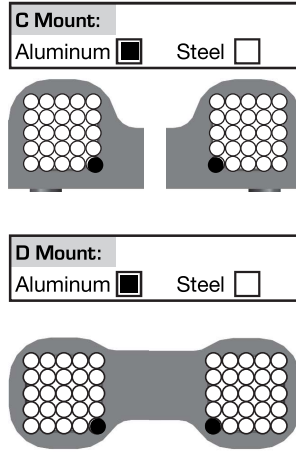

Electronics:

| | |
|--|----------------------------------|
| Radio: Futaba 10TPX | Servo: Savox SB-3262 |
| EPA: Throttle: 96 % | Brake: 92 % |
| ESC: Hobbywing XR10 G3 | |
| ESC Settings: See Setup Sheet | |
| Motor / Wind: Hobbywing 7.0T | Timing: 30° |
| Pinion: #1340 FT 23T | Spur: #92295 Octalock 78T |
| Battery Mount: Std <input checked="" type="checkbox"/> Offset <input type="checkbox"/> | |
| Back 1 <input type="checkbox"/> 2 <input checked="" type="checkbox"/> 3 <input type="checkbox"/> 4 <input type="checkbox"/> 5 <input type="checkbox"/> Forward | |
| Battery: Protek 4800 | Weight: #27355 Reedy 20g |
| Notes: #1370 FT Servo Horn (Ballstud Spaced 3mm Forward) | |

Drivetrain:

| | |
|----------------------|--|
| Differential: | Ball Diff: <input checked="" type="checkbox"/> |
| Height: | 2 |
| Gear Diff: | <input type="checkbox"/> |
| Diff Setting: | #91918 FT Diff Decoder = 240 |
| Notes: | |

Slipper Clutch:

| | |
|-------------------|---------------------------------------|
| Type: | Schelle |
| # of Pads: | White (Inner) / Black / Black (Outer) |
| Setting: | Front Tires Lift 1" |
| Notes: | |

Shocks:

| | Front | Rear |
|------------------------|---|---|
| Piston: | 2 x 1.8 | 2 x 2.0 |
| Thickness: | #91934 2.5mm | #92429 2.5mm |
| Fluid: | #5474 FT 35wt | #5472 FT 30wt |
| Spring: | 1Up Blue | #91948 13mm White |
| Limiters: | Int: 1mm Ext: 0mm | Int: 0mm Ext: 2mm |
| Stroke: | 21.6mm | 27.5mm |
| Eyelet: | +2mm | +2mm |
| Cup Offset: | 0 <input type="checkbox"/> +5 <input checked="" type="checkbox"/> +9 <input type="checkbox"/> | 0 <input type="checkbox"/> +5 <input checked="" type="checkbox"/> +9 <input type="checkbox"/> |
| Kashima Bodies: | <input type="checkbox"/> | Chrome Shafts: <input checked="" type="checkbox"/> Machined Spacers: <input type="checkbox"/> |
| Notes: | | |



Track Info:

| | |
|---------------------|---|
| Size: | Extra Large |
| Surface: | Glued Dirt |
| Traction: | High |
| Moisture: | None |
| Condition: | Most grip after applying glue and fades during the day; Track misted throughout the day |
| Temperature: | 65F |
| Notes: | |

Tires:

| | |
|---|---|
| Front Tires: | JConcepts Silent Rage (80.9mm) |
| Front Compound: | Silver |
| Front Insert: | JConcepts Purple (Foam & Sidewalls Glued) |
| Rear Tires: | JConcepts Smoothie 2 (84.6mm) |
| Rear Compound: | Silver |
| Rear Insert: | JConcepts Dirt Tech |
| Wheel (F/R): | JConcepts Mono |
| Notes: SXT Baja (Apply To Dirty Tires) | |

Body, Weight:

| | |
|------------------------------|--|
| Body: | JConcepts P2 |
| Front Wing: | JConcepts Upper |
| Rear Wing: | JConcepts 7" Aero (Corner Vent Holes) |
| Wing Angle: | 0° <input type="checkbox"/> 3° <input type="checkbox"/> 6° <input checked="" type="checkbox"/> |
| Chassis Length: | #92400 RC10B7 |
| Servo Weights: | #92466 FT Carbon Fiber |
| Electronic Weights: | #91977 FT Carbon Fiber |
| Total Vehicle Weight: | 1510g |

Vehicle Comments:

| | |
|---------------|--------------------------------|
| Notes: | JConcepts Titanium Turnbuckles |
| | JConcepts Titanium Ballstuds |
| | JConcepts Titanium Screw Kit |
| | |
| | |
| | |