



**Driver:** Brent Thielke **Event:** U.S. Carpet Off Road Championships **Qualify:** 2nd **Main:** A - 40+ 2wd Buggy & Pro Modified 2wd Buggy  
**Date:** December 8, 2024 **Track:** Embassy Suites **Finish:** 1st - 40+ **Best Lap Time:** 13.4

### Front Suspension:

**Reset Forms**

Ride Height:	13mm
Camber:	-2°
Toe:	0°
Anti-Roll Bar:	1.0mm
Arm Type:	#92411 FT Carbon
Tower Type:	#92430 Kit
Wheel Hex:	#71034 FT Clamping, 6.0mm
Steering Block KPI:	#91985 B6.4 -1 Scrub, Carbon, 3mm Trail
Caster Block Insert:	0 <input type="checkbox"/> +2.5 <input type="checkbox"/> +5 <input checked="" type="checkbox"/>
Bulkhead Type:	#92436 FT 0°, Aluminum
Kick-Up Angle:	-2.5 <input type="checkbox"/> 0 <input checked="" type="checkbox"/> +2.5 <input type="checkbox"/>
Steering Stop Spacing:	None
Caster Block Spacing:	Fwd <input checked="" type="checkbox"/> Back <input type="checkbox"/>
Notes:	#71181 FT Hex Adapter Front Axles, Titanium #91983 FT Steering Bellcranks, Aluminum

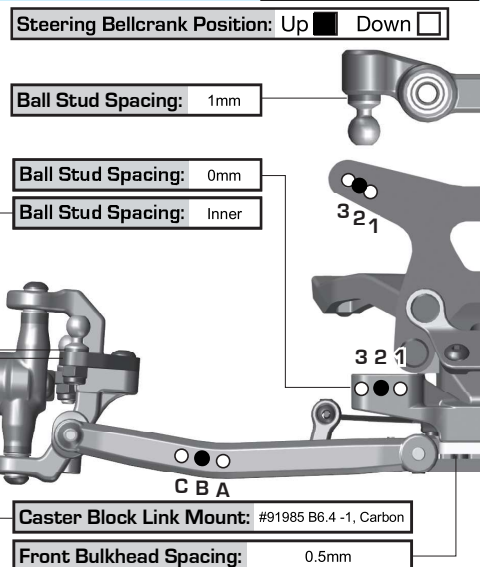
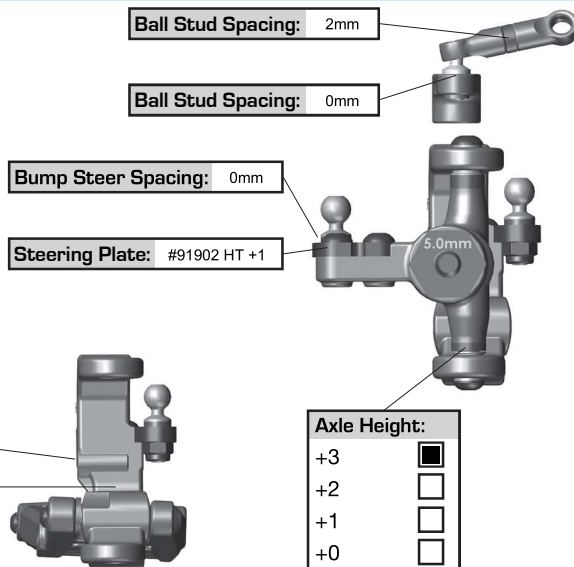

### Rear Suspension:

Ride Height:	13mm
Camber:	-2°
Anti-Roll Bar:	1.2mm
Arm Type:	#92409 FT Carbon
Tower Type:	FT Carbon, -2mm
Arm Spacing:	Fwd <input type="checkbox"/> Mid <input type="checkbox"/> Back <input checked="" type="checkbox"/>
Wheel Hex:	#71034 FT Clamping, 6.0mm
Hub Type:	Std <input type="checkbox"/> HRC <input checked="" type="checkbox"/> #92473 FT Aluminum
Hub Spacing:	Fwd <input type="checkbox"/> Mid <input type="checkbox"/> Back <input checked="" type="checkbox"/>
Drive Shaft:	CVA's <input checked="" type="checkbox"/> Universals <input type="checkbox"/>
Notes:	Hub Tower Bump Out #92434 FT Steel Arm Mount, C (26g)

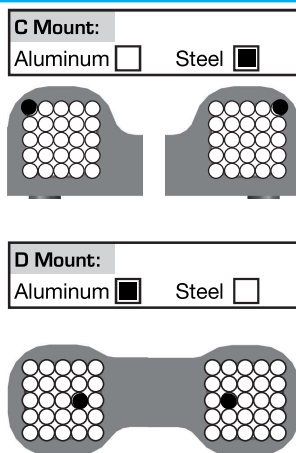

Axle Height:	
▼0 3▲	+3
▼1 2▲	+2
▲1 2▼	+1
▲0 3▼	+0

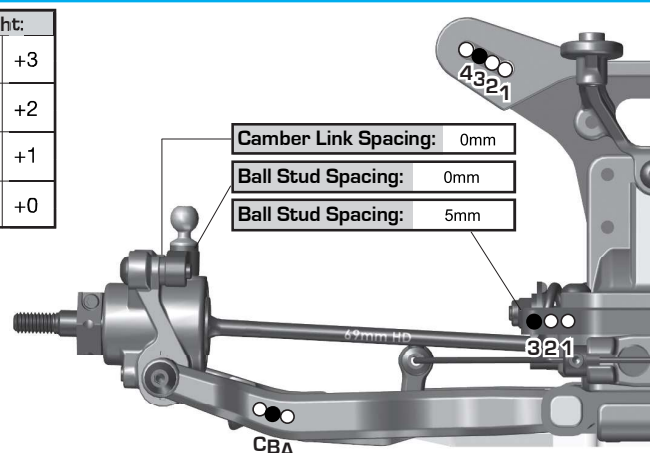

### Electronics:

Radio:	Futaba 10TPX	Servo:	#27115 Reedy RT2007A
EPA: Throttle:	100 %	Brake:	84 %
ESC:	#27017 Reedy Blackbox 610R		
ESC Settings:	See Setup Sheet		
Motor / Wind:	#27446 Reedy Sonic M4 5.5T	Timing:	5°
Pinion:	#1337 FT 20T	Spur:	#92295 Octalock 78T
Battery Mount:	Std <input checked="" type="checkbox"/> Offset <input type="checkbox"/>		
Battery:	#27396 Reedy Zapper 4800	Weight:	None
Notes:	#1363 FT 18.5mm Servo Horn, 25T (5mm Spacing); #27448 Reedy 12.5mm Rotor		

### Drivetrain:

Differential:	Ball Diff: <input type="checkbox"/>		
Height:	2	Gear Diff:	<input checked="" type="checkbox"/>
Diff Setting:	#5458 FT 60k		
Notes:	#92306 FT LCT Metal, 4-Gear Filled 95% Full		

### Slipper Clutch:

Type:	Kit Plates & Spring
# of Pads:	#92288 Octalock 19mm White x 2
Setting:	Front Suspension Unloads, But No Tire Lift
Notes:	

### Shocks:

	Front	Rear
Piston:	3 x 1.6mm	3 x 1.7mm
Thickness:	#91932 2.5mm	#91933 2.5mm
Fluid:	#5475 FT 47.5wt	#5477 FT 42.5wt
Spring:	1Up Pink	1Up Green
Limiters:	Int: 0mm Ext: 3mm	Int: 0mm Ext: 3mm
Stroke:	23.0mm	28mm
Eyelet:	+2mm	0mm
Cup Offset:	0 <input type="checkbox"/> +5 <input checked="" type="checkbox"/> +9 <input type="checkbox"/>	0 <input type="checkbox"/> +5 <input type="checkbox"/> +9 <input type="checkbox"/>
Kashima Bodies:	<input checked="" type="checkbox"/>	Chrome Shafts: <input checked="" type="checkbox"/> Machined Spacers: <input checked="" type="checkbox"/>
Notes:	#91986 FT Fox Shock Upgrade Kit; RM2 Clip On Up Travel Limiters	



### Track Info:

Size:	48' x 96 w/ Particle Board Sub Floor
Surface:	CRC Black Carpet (Broken In w/ Onroad Additive)
Traction:	Very High
Moisture:	None
Condition:	Tires come off sticky; Additive slowly fades from the track by main day
Temperature:	75F
Notes:	

### Tires:

Front Tires:	JConcepts Pin Swags (Sidewalls Glued)
Front Compound:	Double Pink
Front Insert:	None
Rear Tires:	JConcepts Fuzz Bites (Toed In)
Rear Compound:	Double Pink
Rear Insert:	JConcepts (Inner Bead Trimmed For Mounting)
Wheel (F/R):	JConcepts Mono
Notes:	

### Body, Weight:

Body:	JConcepts S2 (Lightweight)
Front Wing:	JConcepts Upper Front Wing
Rear Wing:	JConcepts 6.5" (Wing Mount Nubs Removed)
Wing Angle:	0° <input type="checkbox"/> 3° <input checked="" type="checkbox"/> 6° <input type="checkbox"/>
Chassis Length:	#92490 RC10B7 -4mm
Servo Weights:	None
Electronic Weights:	#91976 FT Aluminum
Total Vehicle Weight:	1484g

### Vehicle Comments:

Notes:	#92360 FT Titanium Turnbuckle Set #91750, 91751, 91752 & 91753 FT Titanium Ballstuds #92406 FT Gearbox, Carbon; #92480 FT One-Piece Servo Mount, Black; #92482 FT Battery Mount Set #92475 FT Motor Mount, Blue; #92488 FT Protective Chassis Sheet; #97423 Reedy 30mm Fan; Schelle Titanium Screws; Steering Curve = -15; Steering Speed = 90/90; Response = Steering 5 / Throttle 5
--------	--