



Driver: Jovy Levin Event: JConcepts Summer Carpet INS Quality: 1st Main: A
 Date: June 9, 2024 Tracks: Island Speedway Finish: 1st Best Lap Time: N/A

Front Suspension:

Reset Forms

Ride Height: 13mm (Body On)
 Camber: -2°
 Toe: 0°
 Anti-Roll Bar: 1.0mm
 Arm Type: #92411 FT Carbon
 Tower Type: #92430 Kit
 Wheel Hex: #91683 FT Titanium, 5mm
 Steering Block KPI: #92415 FT Carbon - 4 Trail / KPI 2
 Caster Block Insert: 0 +2.5 +5
 Bulkhead Type: #92437 FT +2.5/-2.5°, Aluminum
 Kick-Up Angle: -2.5 0 +2.5
 Steering Stop Spacing: None
 Caster Block Spacing: Fwd Back
 Notes: #92404 FT Top Plate & Ballstud Mount, Carbon; #91984 FT Steering Rack, Aluminum; #91983 FT Steering Bellcranks, Aluminum

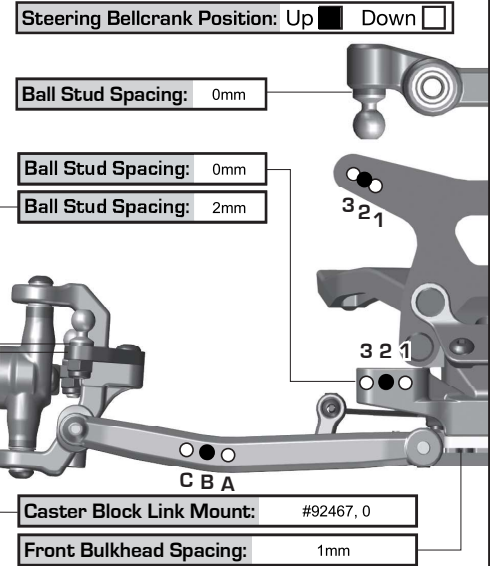
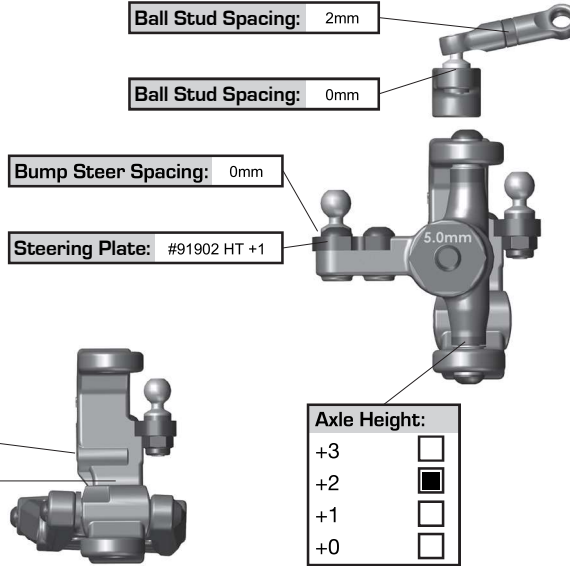

Rear Suspension:

Ride Height: 13mm (Body On)
 Camber: -2°
 Anti-Roll Bar: 1.3mm
 Arm Type: #92409 FT Carbon
 Tower Type: #92431 Kit
 Arm Spacing: Fwd Mid Back
 Wheel Hex: #91609 FT Clamping Hex, 5mm
 Hub Type: Std HRC #92413 FT Carbon
 Hub Spacing: Fwd Mid Back
 Drive Shaft: CVA's Universals
 Notes: #92185 FT Carbon Fiber Camber Shims; #92011 FT 1/0.5 Arm Mount Inserts

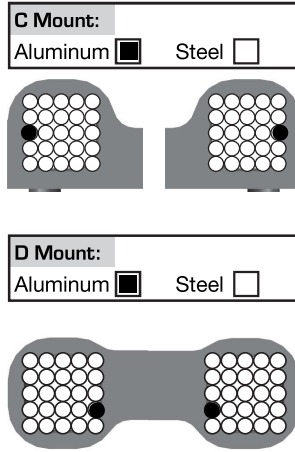

Axle Height:
 ▼0 3▲ +3
 ▼1 2▲ +2
 ▲1 2▼ +1
 ▲0 3▼ +0

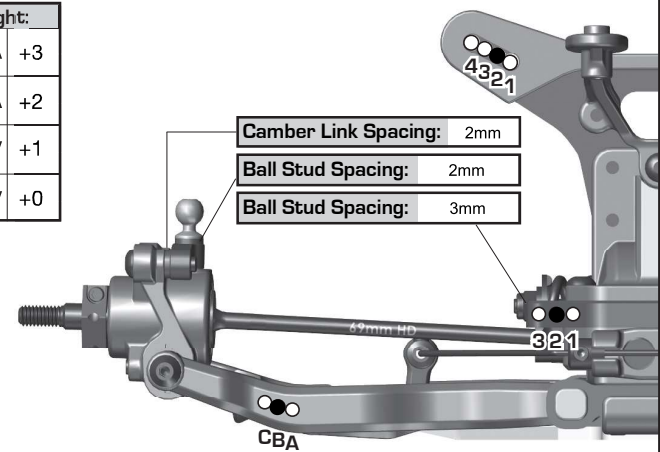

Electronics:

Radio: Sanwa M17 Servo: Team Powers SHT
 EPA: Throttle: 100 % Brake: 100 %
 ESC: Team Powers Radon V5BT
 ESC Settings: See Setup Sheet
 Motor / Wind: Team Powers V5 / 17.5T Timing: 48°
 Pinion: #1350 FT 32T Spur: #92293 Octalock 72T
 Battery Mount: Std Offset
 Battery: Team Powers 6800 mAh Weight: None
 Notes:

Drivetrain:

Differential: Ball Diff:
 Height: 3 Gear Diff:
 Diff Setting: #5458 FT 60k
 #92306 LTC Gear Set, Metal, 2-gear
 Notes: #92322 FT 2-Gear Steel Cross Pins

Slipper Clutch:

Type: #91802 & 91806 FT Vented Slipper Hubs
 # of Pads: #92285 FT Octalock 11mm LCF x 2
 Setting: Tight
 Notes: #91891 B6.3 HD Slipper Spring; #91797 FT Titanium Top Shaft

Shocks:

	Front	Rear
Piston:	2 x 1.7	2 x 1.9
Thickness:	#91933 FT 2.5mm	#92428 FT 2.5mm
Fluid:	#5474 FT 35wt	#5473 FT 32.5wt
Spring:	Core RC Orange	Core RC Black
Limiters:	Int: 1mm Ext: 3mm	Int: 0mm Ext: 5mm
Stroke:	22.0mm	29mm
Eyelet:	+2mm	+2mm
Cup Offset:	0 <input type="checkbox"/> +5 <input type="checkbox"/> +9 <input type="checkbox"/>	0 <input type="checkbox"/> +5 <input type="checkbox"/> +9 <input type="checkbox"/>
Kashima Bodies:	<input checked="" type="checkbox"/>	Chrome Shafts: <input checked="" type="checkbox"/> Machined Spacers: <input checked="" type="checkbox"/>
Notes:	Rear Shocks Inverted; Schumacher Cougar Laydown Spring Cups	

Track Info:

Size: Medium
 Surface: Black Carpet
 Traction: Medium-High
 Moisture: None
 Condition: Fuzzes Up Off Racing Line
 Temperature: 60F
 Notes:

Tires:

Front Tires: JConcepts Slim Pin Swags (Glued Sidewalls)
 Front Compound: Pink
 Front Insert: None
 Rear Tires: JConcepts Fuzz Bites (Toed In)
 Rear Compound: Pink
 Rear Insert: JConcepts Open Cell
 Wheel (F/R): JConcepts Mono
 Notes:

Body, Weight:

Body: JConcepts F2 (Lightweight)
 Front Wing: #92425 B7
 Rear Wing: #92424 B7 (6mm Corner Vent Holes)
 Wing Angle: 0° 3° 6°
 Chassis Length: #92490 RC10B7 -4mm
 Servo Weights: None
 Electronic Weights: #91977 FT Steel
 Total Vehicle Weight: 1510g

Vehicle Comments:

Notes: #92402 FT Side Rails, Carbon
 #92406 FT Gearbox, Carbon
 JConcepts Titanium Top Screw Kit
 JConcepts Titanium Turnbuckles