

## Front Suspension:

Reset Forms

<b>Ride Height:</b>	21 mm
<b>Camber:</b>	-1
<b>Toe:</b>	+1
<b>Arm Type:</b>	#91672 Flat Arm, Hard
<b>Tower Type:</b>	Flat
<b>Caster Block Insert:</b>	5°
<b>Bulkhead Type:</b>	#91658 FT Aluminum
<b>Kick-Up Angle:</b>	25°
<b>Wheel Hex:</b>	#91682 Aluminum 5 mm
<b>Notes:</b>	#91668 Aluminum Steering Bellcrank #91669 Aluminum Steering Rack #1364 Factory Team Aluminum Steering Horn

<b>Anti Roll Bar:</b>	None <input checked="" type="checkbox"/>
	White (0.8mm) <input type="checkbox"/>
	Gray (0.9mm) <input type="checkbox"/>
	Blue (1.0mm) <input type="checkbox"/>
	Other: <input type="checkbox"/>

<b>Bump Steer Spacing:</b>	1 mm
----------------------------	------

<b>Axle Height:</b>	+3 <input type="checkbox"/>
	+2 <input type="checkbox"/>
	+1 <input checked="" type="checkbox"/>
	0 <input type="checkbox"/>

<b>Ball Stud Spacing:</b>	2 mm
---------------------------	------

<b>Steering Plate:</b>	#91679 Kit Aluminum
------------------------	---------------------

<b>Steering Stop Spacing:</b>	0
-------------------------------	---

<b>Caster Block Spacing:</b>	1 mm
------------------------------	------

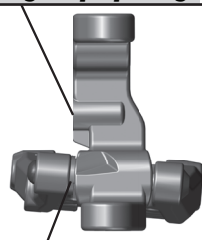
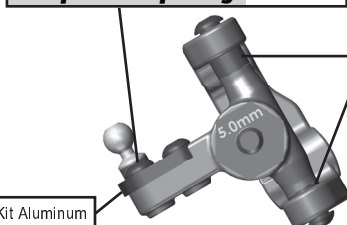

<b>Ball Stud Spacing:</b>	2 mm
---------------------------	------

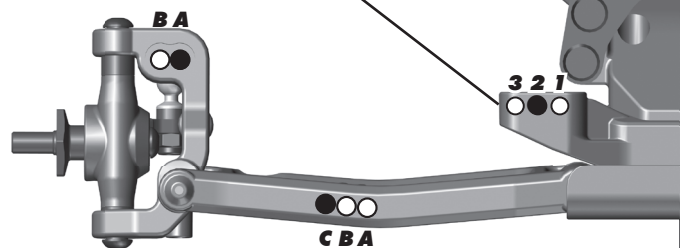

## Rear Suspension:

<b>Ride Height:</b>	21 mm
<b>Camber:</b>	-1
<b>Wheel Hex:</b>	#91610 Clamping 7 mm
<b>Hub Spacing:</b>	Forward <input type="checkbox"/> Middle <input checked="" type="checkbox"/> Back <input type="checkbox"/>
<b>Shock Mounting Position:</b>	Front of Arm <input type="checkbox"/> Rear of Arm <input checked="" type="checkbox"/>
<b>Notes:</b>	#91687 Brass Arm Mount, C 12g #91688 Aluminum Arm Mount, D #91696 Rear Arms, Hard

<b>Anti Roll Bar:</b>	None <input checked="" type="checkbox"/>
	White (1.2mm) <input type="checkbox"/>
	Gray (1.3mm) <input type="checkbox"/>
	Blue (1.4mm) <input type="checkbox"/>
	Other: <input type="checkbox"/>

<b>C Mount Inserts:</b>	1° <input type="checkbox"/> 0.5° <input checked="" type="checkbox"/>
-------------------------	--

<b>D Mount Inserts:</b>	1° <input type="checkbox"/> 0.5° <input checked="" type="checkbox"/>
-------------------------	--



### Rear Hub Link Setting:

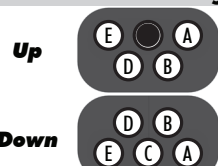

<b>Hub Insert:</b>	+3 <input type="checkbox"/> +2 <input type="checkbox"/> +1 <input checked="" type="checkbox"/> 0 <input type="checkbox"/>
--------------------	---

<b>Ball Stud Spacing:</b>	3 mm
---------------------------	------

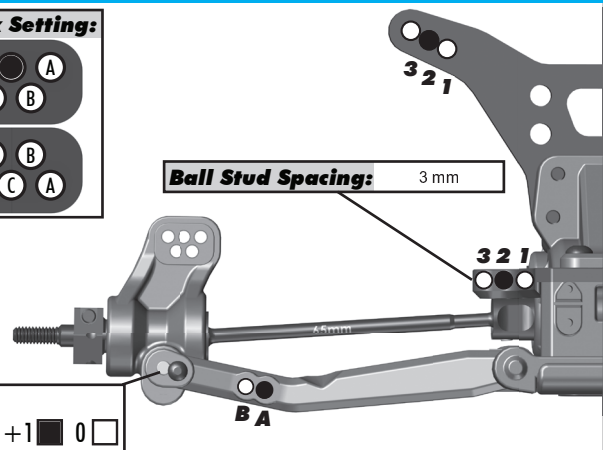

## Electronics:

<b>Radio:</b>	<b>Servo:</b> Reedy #1408 LP
<b>EPA: Throttle:</b> 100 %	<b>% Brake:</b> 80 %
<b>ESC:</b>	Reedy
<b>ESC Settings:</b>	
<b>Motor:</b>	Reedy Sonic M3
<b>Wind:</b> 8.0	<b>Timing:</b> 20°
<b>Pinion:</b> 23	<b>Spur:</b> 78
<b>Battery:</b>	Reedy 5300 mAh #322 (18g Under Battery)
<b>Battery Position:</b>	2F

## Drivetrains:

<b>Transmission:</b>	
<b>3 Gear:</b> <input checked="" type="checkbox"/>	<b>4 Gear:</b> <input type="checkbox"/>
<b>Stand Up:</b> <input type="checkbox"/>	<b>Lay Down:</b> <input checked="" type="checkbox"/>
<b>Differential:</b>	
<b>Ball Diff:</b> <input checked="" type="checkbox"/>	<b>Gear Diff:</b> <input type="checkbox"/>
<b>Notes:</b>	Tight
<b>Slipper Clutch:</b>	
<b>Type:</b>	#7495 FT V2
<b># of Pads:</b>	2

## Shocks:

	Front	Rear
<b>Piston:</b>	2 x 1.5 Flat Kit	3 x 1.4 Flat
<b>Fluid:</b>	30 wt	27.5 wt
<b>Spring:</b>	Gray	Green
<b>Limiters:</b>	2	0
<b>Stroke:</b>	20.5 mm	28 mm
<b>Eyelet Length:</b>	Long	Long
<b>Cup Offset:</b>	5 mm	0 mm
<b>Notes:</b>	X-Rings; Machined Internals; Chrome Shafts	



## Track Info:

<b>Size:</b>	Small <input checked="" type="checkbox"/> Medium <input type="checkbox"/> Large <input checked="" type="checkbox"/> Extra Large <input type="checkbox"/>
<b>Surface:</b>	Dirt <input checked="" type="checkbox"/> Carpet <input type="checkbox"/> Astroturf <input type="checkbox"/> Multi Surface <input type="checkbox"/>
<b>Traction:</b>	Low <input type="checkbox"/> Medium <input type="checkbox"/> High <input checked="" type="checkbox"/> Very High <input checked="" type="checkbox"/>
<b>Moisture:</b>	Dry <input checked="" type="checkbox"/> Damp <input type="checkbox"/> Wet <input type="checkbox"/>
<b>Condition:</b>	Indoor <input checked="" type="checkbox"/> Outdoor <input type="checkbox"/> Dusty <input type="checkbox"/> Hard Packed <input checked="" type="checkbox"/> Bumpy <input type="checkbox"/> Grooved <input checked="" type="checkbox"/> Smooth <input checked="" type="checkbox"/> Loamy <input type="checkbox"/>
<b>Temperature:</b> Ambient: 80°	Track: 80°
<b>Notes:</b>	

## Tires:

<b>Front Tires:</b>	JConcepts Smoothies
<b>Front Compound:</b>	Gold
<b>Front Insert:</b>	JConcepts Dirt Tech
<b>Rear Tires:</b>	JConcepts Smoothies
<b>Rear Compound:</b>	Gold
<b>Rear Insert:</b>	JConcepts Dirt Tech
<b>Wheel (F/R):</b>	Team Associated 60 mm
<b>Notes:</b>	

## Body, Wing, Weight:

<b>Body:</b>	Team Associated Kit Lightweight
<b>Wing:</b>	Team Associated Kit
<b>Wing Angle:</b>	0° <input type="checkbox"/> 3° <input checked="" type="checkbox"/> 6° <input type="checkbox"/>
<b>Servo Weights:</b>	None <input type="checkbox"/> Aluminum <input checked="" type="checkbox"/> Steel <input type="checkbox"/> Other <input type="checkbox"/>
<b>Electronic Weights:</b>	None <input type="checkbox"/> Aluminum <input checked="" type="checkbox"/> Steel <input type="checkbox"/> Other <input type="checkbox"/>
<b>Total Vehicle Weight:</b>	1548g

## Vehicle Comments:

**Notes:** Titanium Screw Kit;