

Front Suspension:

Reset Forms

Ride Height:	21.0 mm
Camber:	-1
Toe:	0
Arm Type:	#91672 Flat; Hard
Tower Type:	Flat
Caster Block Insert:	5°
Bulkhead Type:	#91656 Plastic
Kick-Up Angle:	25°
Wheel Hex:	#91682 Kit Aluminum; 5 mm
Notes:	

Anti Roll Bar:

None

White (0.8mm)

Gray (0.9mm)

Blue (1.0mm)

Other:

Bump Steer Spacing: 0.5 mm

Axle Height:

+3

+2

+1

0

Ball Stud Spacing: 0 mm

Steering Plate: #91679 Kit Aluminum

Steering Stop Spacing: 0

Ball Stud Spacing: 1.5 mm

Caster Block Spacing: 1 mm

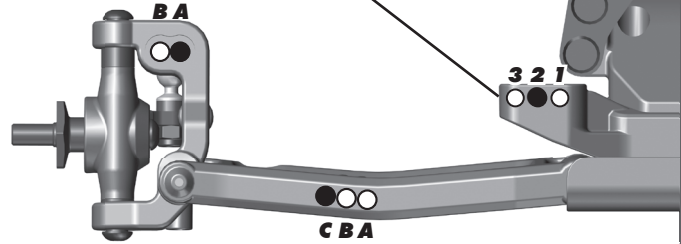
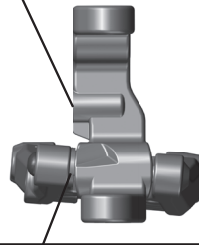
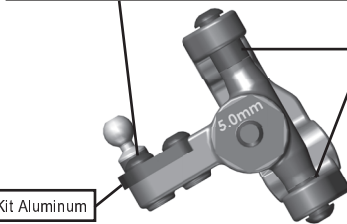

Rear Suspension:

Ride Height:	20.75 mm
Camber:	-1
Wheel Hex:	#91610 Clamping; 7.0 mm
Hub Spacing:	Forward <input type="checkbox"/> Middle <input checked="" type="checkbox"/> Back <input type="checkbox"/>
Shock Mounting Position:	Front of Arm <input type="checkbox"/> Rear of Arm <input checked="" type="checkbox"/>
Notes:	#91687 Brass Arm Mount, C
	#91688 Aluminum Arm Mount, D
	#91696 Rear Arms, Hard

Anti Roll Bar:

None

White (1.2mm)

Gray (1.3mm)

Blue (1.4mm)

Other:

Rear Hub Link Setting:

Up

E A

D B

Down

D B

E C A

C Mount Inserts: 1° 0.5°

D Mount Inserts: 1° 0.5°

Hub Insert:

+3 +2 +1 0

Ball Stud Spacing: 1.5 mm

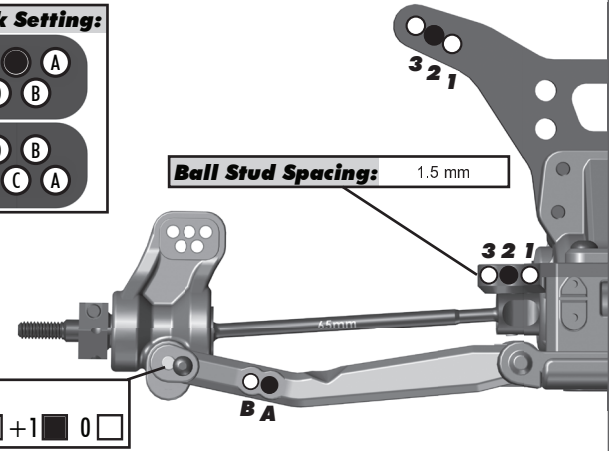
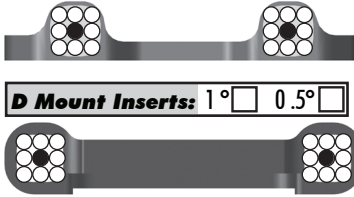

Electronics:

Radio:	Sanwa M12	Servo:	Reedy 1508
EPA: Throttle:	100 %	Brake:	85 %
ESC:	Reedy Blackbox 1000Z+		
ESC Settings:	4/2/1/3/4/1/1/1		
Motor:	Reedy Sonic M3		
Wind:	7.0	Timing:	10°
Pinion:	22	Spur:	78
Battery:	Reedy Wolf Pack Shorty #738 (54g Under Battery)		
Battery Position:	4F		

Drivetrains:

Transmission:

3 Gear: **4 Gear:**

Stand Up: **Lay Down:**

Differential:

Ball Diff: **Gear Diff:**

Notes: Tight

Slipper Clutch:

Type: Team Associated V2 #7495

of Pads: 2

Shocks:

	Front	Rear
Piston:	2 x 1.6 Machined	2 x 1.7 Machined
Fluid:	35 wt	29 wt
Spring:	Gray	Green
Limiters:	2	0
Stroke:	20.5	28.0
Eyelet Length:	Long	Long
Cup Offset:	5 mm	5 mm
Notes:	Chrome Shock Shafts; X-Rings; Machined Int.	

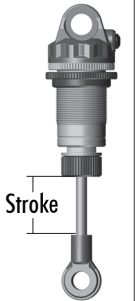

Track Info:

Size: Small Medium Large Extra Large

Surface: Dirt Carpet Astroturf Multi Surface

Traction: Low Medium High Very High

Moisture: Dry Damp Wet

Condition: Indoor Outdoor Dusty Hard Packed

Bumpy Grooved Smooth Loamy

Temperature: Ambient: 65F Track: 65F

Notes:

Tires:

Front Tires: JConcepts Dirt Webs

Front Compound: Gold

Front Insert: JConcepts Dirt Tech

Rear Tires: JConcepts Dirt Webs

Rear Compound: Gold

Rear Insert: JConcepts Dirt Tech

Wheel (F/R): Team Associated

Notes:

Body, Wing, Weight:

Body: Team Associated Kit; Lightweight

Wing: Kit JConcepts Narrow Upper Front Wing

Wing Angle: 0° 3° 6°

Servo Weights:

None Aluminum Steel Other

Electronic Weights:

None Aluminum Steel Other

Total Vehicle Weight: 1530g

Vehicle Comments:

Notes: #91755 Titanium Screw Kit; Plastic Servo Horn; #27304 Reedy Under Battery Weights;