

## Front Suspension:

<b>Ride Height:</b>	20 mm
<b>Camber:</b>	-1/2°
<b>Toe:</b>	0
<b>Anti-Roll Bar:</b>	1.2 mm (Green)
<b>Wheelbase Shim:</b>	Front (Arms Back)
<b>Wheel Hex:</b>	#92063 3.5 mm, Kit
<b>Caster Block:</b>	7° <input type="checkbox"/> 10° <input checked="" type="checkbox"/> 13° <input type="checkbox"/>
<b>Notes:</b>	Ring / Pinion Shimming = 0/7

**Axle Height:**

+3

+2

+1

0

**Bump Steer Spacing:** 1 mm

**Ball Stud Spacing:** 1 mm

**Steering Plate:** Schelle Type 1

**Ball Stud Spacing:** 1 mm

**Arm Mount A:**

LRC  HRC  1°  0.5°



**Arm Mount B:**

LRC  HRC  1°  0.5°

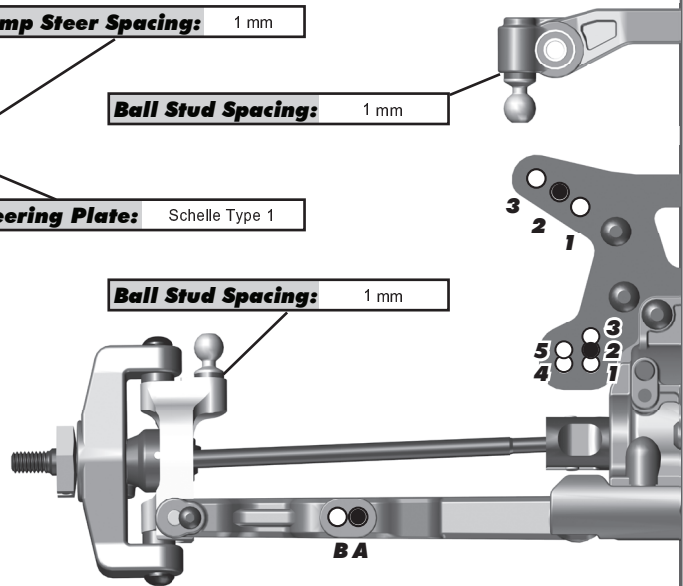

## Rear Suspension:

<b>Ride Height:</b>	20 mm
<b>Camber:</b>	-1°
<b>Anti-Roll Bar:</b>	1.5 mm (Blue)
<b>Wheelbase Shim:</b>	Back (Arms Forward)
<b>Wheel Hex:</b>	#91609 5.0 mm
<b>Hub Spacing:</b>	Forward <input type="checkbox"/> Middle <input checked="" type="checkbox"/> Back <input type="checkbox"/>
<b>Gearbox Shim:</b>	Yes <input checked="" type="checkbox"/> No <input type="checkbox"/>
<b>Chassis Brace:</b>	Short <input type="checkbox"/> Long <input checked="" type="checkbox"/>
<b>Notes:</b>	Schelle Prototype 1mm Gearbox Shim Ring / Pinion Shimming = 0/7

**Arm Mount C:**

LRC  HRC  1°  0.5°



**Arm Mount D:**

LRC  HRC  1°  0.5°



### Rear Hub Link Setting:

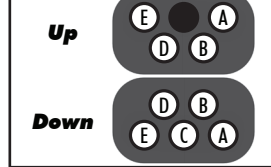

**Hub Insert:**

+3  +2  +1  0

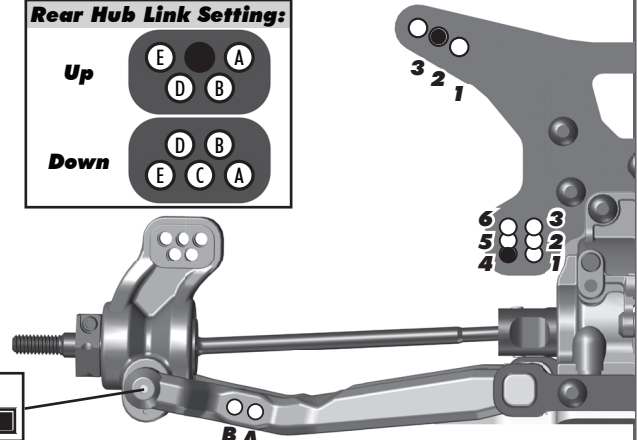

## Electronics:

<b>Radio:</b>	Sanwa M12S	<b>Servo:</b>	Sanwa
<b>EPA: Throttle:</b>	100 %	<b>Brake:</b>	85 %
<b>ESC:</b>	Reedy Blackbox 410R		
<b>ESC Settings:</b>	80% Brake Strength; 3,200 hZ Brake Freq; 5° Top Timing		
<b>Motor:</b>	Reedy M3		
<b>Wind:</b>	6.5	<b>Timing:</b>	15°
<b>Pinion:</b>	19	<b>Spur:</b>	81
<b>Battery:</b>	#322 Reedy 5300 mAh		
<b>Battery Position:</b>	Forward		

## Differential:

<b>Front Fluid:</b>	10,000
<b>Gears:</b>	Plastic <input type="checkbox"/> Metal <input checked="" type="checkbox"/>
<b>Center Fluid:</b>	100,000
<b>Gears:</b>	Plastic <input type="checkbox"/> Metal <input checked="" type="checkbox"/>
<b>Rear Fluid:</b>	7,000
<b>Gears:</b>	Plastic <input type="checkbox"/> Metal <input checked="" type="checkbox"/>
<b>Slipper Clutch:</b>	
<b>Type:</b>	N/A
<b># of Pads:</b>	N/A

## Shocks:

	Front	Rear
<b>Piston:</b>	2 x 1.6 Schelle	2 x 1.7 Schelle Bevel
<b>Fluid:</b>	37.5 wt	27.5 wt
<b>Spring:</b>	Yellow	White
<b>Limiters:</b>	3	0
<b>Stroke:</b>	21.0 mm	28.0 mm
<b>Eyelet Length:</b>	Short	Short
<b>Cup Offset:</b>	5 mm	0 mm
<b>Notes:</b>		

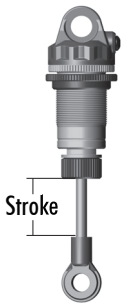

## Track Info:

<b>Size:</b>	Small <input type="checkbox"/> Medium <input checked="" type="checkbox"/> Large <input type="checkbox"/> Extra Large <input type="checkbox"/>
<b>Surface:</b>	Dirt <input checked="" type="checkbox"/> Carpet <input type="checkbox"/> Astroturf <input type="checkbox"/> Multi Surface <input type="checkbox"/>
<b>Traction:</b>	Low <input type="checkbox"/> Medium <input checked="" type="checkbox"/> High <input type="checkbox"/> Very High <input type="checkbox"/>
<b>Moisture:</b>	Dry <input checked="" type="checkbox"/> Damp <input type="checkbox"/> Wet <input type="checkbox"/>
<b>Condition:</b>	Indoor <input checked="" type="checkbox"/> Outdoor <input type="checkbox"/> Dusty <input type="checkbox"/> Hard Packed <input checked="" type="checkbox"/> Bumpy <input checked="" type="checkbox"/> Grooved <input type="checkbox"/> Smooth <input type="checkbox"/> Loamy <input type="checkbox"/>
<b>Temperature:</b>	Ambient: _____ Track: _____
<b>Notes:</b>	

## Tires:

<b>Front Tires:</b>	JConcepts Dirt Webs
<b>Front Compound:</b>	Gold
<b>Front Insert:</b>	AKA Red Closed Cell
<b>Rear Tires:</b>	JConcepts Dirt Webs
<b>Rear Compound:</b>	Gold
<b>Rear Insert:</b>	JConcepts Dirt Tech
<b>Wheel (F/R):</b>	#92096 & #9696 Team Associated
<b>Notes:</b>	

## Body, Wing, Weight:

<b>Body:</b>	#92087 Team Associated Kit
<b>Wing:</b>	#91741 Team Associated Kit
<b>Wing Angle:</b>	0° <input type="checkbox"/> 3° <input type="checkbox"/> 6° <input checked="" type="checkbox"/>
<b>Chassis Weights:</b>	None <input checked="" type="checkbox"/> 15g <input type="checkbox"/> 30g <input type="checkbox"/> Other <input type="checkbox"/>
<b>Other Weights:</b>	
<b>Total Vehicle Weight:</b>	1761g

## Vehicle Comments:

**Notes:** Schelle Upper Ti Screw Kit