

Front Suspension:

Ride Height:	18 mm
Camber:	-1 deg
Toe:	+1 deg (Tierod Gap = 23.65 mm)
Anti-Roll Bar:	None
Wheelbase Shim:	Front (Arms Back)
Wheel Hex:	#71034 FT Clamping Hex, 6 mm
Caster Block:	7° <input type="checkbox"/> 10° <input checked="" type="checkbox"/> 13° <input type="checkbox"/>
Notes:	#92025 Front Arms, Standard #92103 FT Aluminum Steering Rack #92006 FT Graphite Adjustable Bellcrank Input Arm (Middle) #1363 FT Aluminum Clamping Servo Horn, 18.5 mm Front Diff Raised 1mm (Schelle Carbon Fiber Shim) RC Speed Secrets Front Shock Tower (#3 Position)

Axle Height:

+3

+2

+1

0

Bump Steer Spacing: 1 mm

Ball Stud Spacing: 2 mm

Steering Plate: #91679 B6 Kit

Ball Stud Spacing: 2 mm

Arm Mount A:

LRC HRC 1° 0.5°

Arm Mount B:

LRC HRC 1° 0.5°

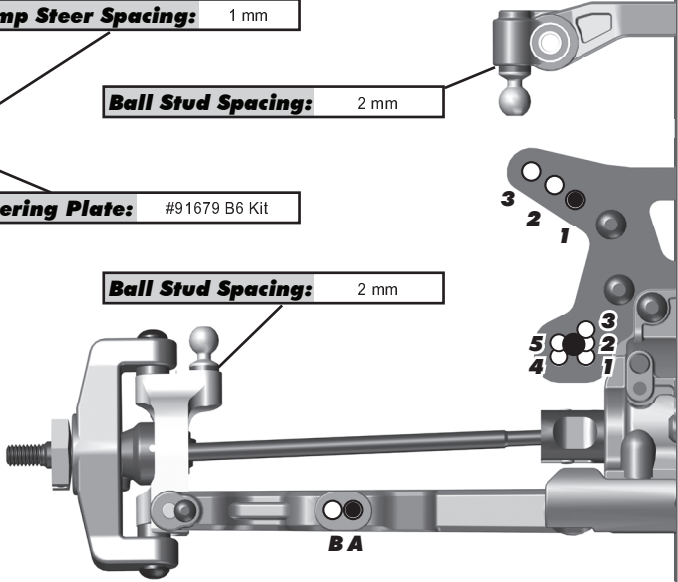

Rear Suspension:

Ride Height:	19 mm
Camber:	-1 deg
Anti-Roll Bar:	1.3 mm (White)
Wheelbase Shim:	1 mm Forward (Arms Back)
Wheel Hex:	#91609 FT Clamping Hex, 5 mm
Hub Spacing:	Forward <input type="checkbox"/> Middle <input checked="" type="checkbox"/> Back <input type="checkbox"/>
Gearbox Shim:	Yes <input type="checkbox"/> No <input checked="" type="checkbox"/>
Chassis Brace:	Short <input checked="" type="checkbox"/> Long <input type="checkbox"/>
Notes:	Shock Standoffs Shimmed Forward 2mm #92049 B64 Hard Rear Arms; #92098 FT Aluminum Hubs (Center Row/Middle +3mm); Camber link on front of tower

Arm Mount C:

LRC HRC 1° 0.5°



Arm Mount D:

LRC HRC 1° 0.5°



Rear Hub Link Setting:

Up

E A
D B

Down

D B
E C A

Hub Insert:

+3 +2 +1 0

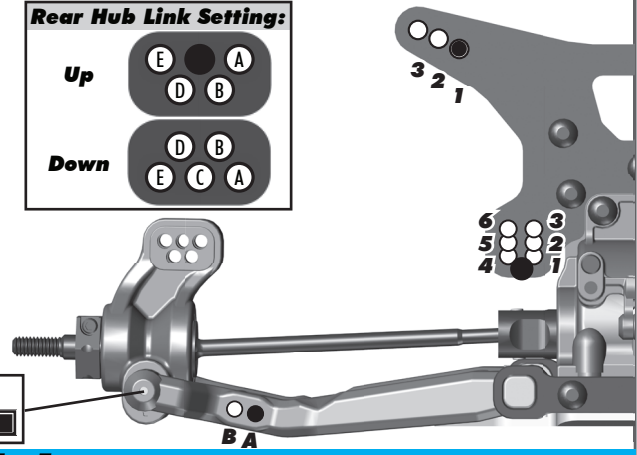

Electronics:

Radio:	Sanwa M12S	Servo:	Reedy RT1508
EPA: Throttle:	100 %	Brake:	100 %
ESC:	Reedy Blackbox 510R		
ESC Settings:	See Setup Sheet		
Motor:	Reedy M3 (#275 12.5 Mod Rotor)		
Wind:	5.5	Timing:	20°
Pinion:	18	Spur:	81
Battery:	#27307 Reedy Zapper 70C		
Battery Position:	Forward		

Differential:

Front Fluid:	5,000
Gears:	Plastic <input type="checkbox"/> Metal <input checked="" type="checkbox"/>
Center Fluid:	N/A
Gears:	Plastic <input type="checkbox"/> Metal <input type="checkbox"/>
Rear Fluid:	5,000
Gears:	Plastic <input type="checkbox"/> Metal <input checked="" type="checkbox"/>
Slipper Clutch:	Type: Schelle
# of Pads:	3 White

Shocks:

	Front	Rear
Piston:	2 x 1.5 Flat	2 x 1.7 Flat
Fluid:	35 wt	30 wt
Spring:	AE Yellow	X-Gear Red
Limiters:	1 mm	0 mm
Stroke:	22 mm	29.50 mm
Eyelet Length:	Long	Long
Cup Offset:	9 mm	5 mm
Notes:	#91494 Machined Shock Spacers	

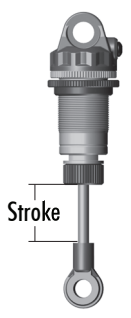

Track Info:

Size:	Small <input type="checkbox"/> Medium <input checked="" type="checkbox"/> Large <input type="checkbox"/> Extra Large <input type="checkbox"/>		
Surface:	Dirt <input checked="" type="checkbox"/> Carpet <input type="checkbox"/> AstroTurf <input type="checkbox"/> Multi Surface <input type="checkbox"/>		
Traction:	Low <input type="checkbox"/> Medium <input type="checkbox"/> High <input type="checkbox"/> Very High <input checked="" type="checkbox"/>		
Moisture:	Dry <input checked="" type="checkbox"/> Damp <input type="checkbox"/> Wet <input type="checkbox"/>		
Condition:	Indoor <input checked="" type="checkbox"/> Outdoor <input type="checkbox"/> Dusty <input type="checkbox"/> Hard Packed <input checked="" type="checkbox"/> Bumpy <input type="checkbox"/> Grooved <input type="checkbox"/> Smooth <input checked="" type="checkbox"/> Loamy <input type="checkbox"/>		
Temperature: Ambient:	65F	Track:	65F
Notes:			

Tires:

Front Tires:	JConcepts Octogon
Front Compound:	Gold
Front Insert:	JConcepts Dirt Tech
Rear Tires:	JConcepts Octogon
Rear Compound:	Gold
Rear Insert:	JConcepts Dirt Tech
Wheel (F/R):	JConcepts Mono
Notes:	

Body, Wing, Weight:

Body:	JConcepts S2 Lightweight
Wing:	JConcepts Aero (Short Cord)
Wing Angle:	0° <input type="checkbox"/> 3° <input type="checkbox"/> 6° <input checked="" type="checkbox"/>
Chassis Weights:	#92190 FT Steel Chassis Weight None <input type="checkbox"/> 15g <input checked="" type="checkbox"/> 30g <input type="checkbox"/> Other <input type="checkbox"/>
Other Weights:	15g Under Center/Rear Driveline In Front Of "C" Block
Total Vehicle Weight:	1741g

Vehicle Comments:

Notes: #91576 & 91578 FT Fox Shock Bodies; #91618 & #91620 FT Chrome Shock Shafts; #92031 Rear Shock Tower, Long