

Front Suspension:

Ride Height:	18 mm
Camber:	-1°
Toe:	0°
Anti-Roll Bar:	1.2 mm (Green)
Wheelbase Shim:	Back (Arm Forward)
Wheel Hex:	#92032 3.5 mm (Kit)
Caster Block:	7° <input type="checkbox"/> 10° <input checked="" type="checkbox"/> 13° <input type="checkbox"/>
Notes:	#92026 Hard Front A-Arms #1363 FT Aluminum Servo Horn, 18.5 mm

Axle Height:	+3 <input type="checkbox"/>
	+2 <input type="checkbox"/>
	+1 <input checked="" type="checkbox"/>
	0 <input type="checkbox"/>

Bump Steer Spacing:	1 mm
----------------------------	------

Ball Stud Spacing:	0 mm
---------------------------	------

Steering Plate:	#92032 (Kit)
------------------------	--------------

Ball Stud Spacing:	1 mm
---------------------------	------

Arm Mount A:	LRC <input checked="" type="checkbox"/> HRC <input type="checkbox"/> 1° <input checked="" type="checkbox"/> 0.5° <input type="checkbox"/>
---------------------	---



Arm Mount B:	LRC <input checked="" type="checkbox"/> HRC <input type="checkbox"/> 1° <input checked="" type="checkbox"/> 0.5° <input type="checkbox"/>
---------------------	---

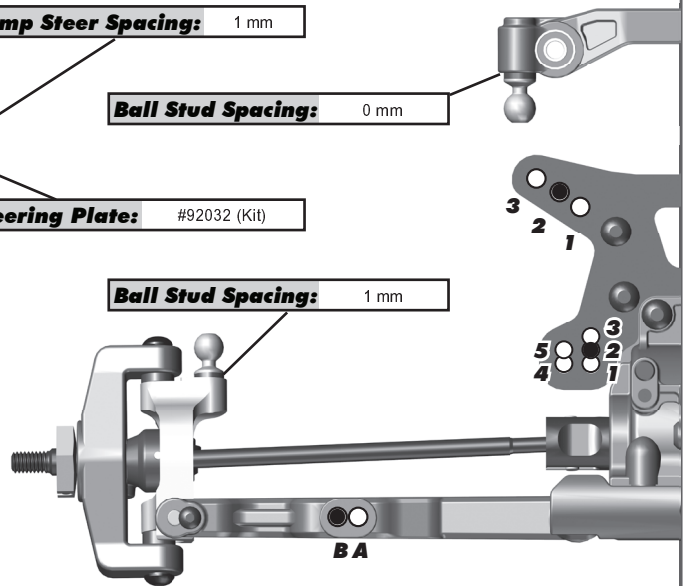

Rear Suspension:

Ride Height:	18 mm
Camber:	-1°
Anti-Roll Bar:	1.5 mm (Blue)
Wheelbase Shim:	Front (Arm Back)
Wheel Hex:	#91609 5.0 mm
Hub Spacing:	Forward <input type="checkbox"/> Middle <input type="checkbox"/> Back <input checked="" type="checkbox"/>
Gearbox Shim:	Yes <input type="checkbox"/> No <input checked="" type="checkbox"/>
Chassis Brace:	Short <input type="checkbox"/> Long <input checked="" type="checkbox"/>
Notes:	#92049 Hard Rear Arms #92013 B64 Rear Shock Tower, Long

Arm Mount C:	LRC <input checked="" type="checkbox"/> HRC <input type="checkbox"/> 1° <input checked="" type="checkbox"/> 0.5° <input type="checkbox"/>
---------------------	---



Arm Mount D:	LRC <input checked="" type="checkbox"/> HRC <input type="checkbox"/> 1° <input checked="" type="checkbox"/> 0.5° <input type="checkbox"/>
---------------------	---



Rear Hub Link Setting:

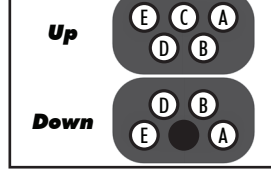

Hub Insert:	+3 <input checked="" type="checkbox"/> +2 <input type="checkbox"/> +1 <input type="checkbox"/> 0 <input type="checkbox"/>
--------------------	---

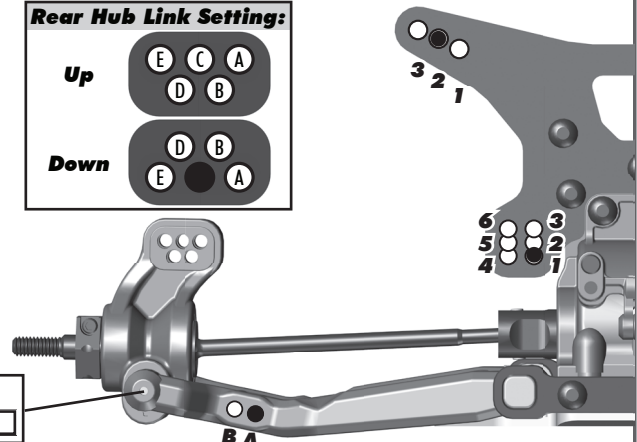

Electronics:

Radio:	Sanwa M12S	Servo:	#27100 Reedy RS1206
EPA: Throttle:	100 %	Brake:	90 %
ESC:	#27004 Reedy Blackbox 510R		
ESC Settings:	N/A		
Motor:	Reedy M3 (#275 12.5mm Mod Rotor)		
Wind:	5.5	Timing:	20°
Pinion:	#1337 Factory Team 19T	Spur:	81
Battery:	#27307 Reedy Zapper 5800 mAh 70C		
Battery Position:	Forward		

Differential:

Front Fluid:	7,000
Gears:	Plastic <input type="checkbox"/> Metal <input checked="" type="checkbox"/>
Center Fluid:	N/A
Gears:	Plastic <input type="checkbox"/> Metal <input type="checkbox"/>
Rear Fluid:	5,000
Gears:	Plastic <input type="checkbox"/> Metal <input checked="" type="checkbox"/>

Slipper Clutch:

Type:	#92089 B64 Slipper Kit
# of Pads:	3 LCF Pads

Shocks:

	Front	Rear
Piston:	2 x 1.6 Flat Machined	2 x 1.7 Flat Machined
Fluid:	37.5 wt	30 wt
Spring:	AE Red	AE White
Limiters:	1	1
Stroke:	21.5 mm	28.0 mm
Eyelet Length:	Long	Short
Cup Offset:	9 mm	5 mm
Notes:	#91494 Machined Internals, #91493 X-Rings	

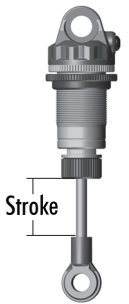

Track Info:

Size:	Small <input type="checkbox"/> Medium <input checked="" type="checkbox"/> Large <input type="checkbox"/> Extra Large <input type="checkbox"/>		
Surface:	Dirt <input checked="" type="checkbox"/> Carpet <input type="checkbox"/> Astroturf <input type="checkbox"/> Multi Surface <input type="checkbox"/>		
Traction:	Low <input type="checkbox"/> Medium <input type="checkbox"/> High <input checked="" type="checkbox"/> Very High <input type="checkbox"/>		
Moisture:	Dry <input checked="" type="checkbox"/> Damp <input type="checkbox"/> Wet <input type="checkbox"/>		
Condition:	Indoor <input checked="" type="checkbox"/> Outdoor <input type="checkbox"/> Dusty <input type="checkbox"/> Hard Packed <input type="checkbox"/> Bumpy <input type="checkbox"/> Grooved <input checked="" type="checkbox"/> Smooth <input checked="" type="checkbox"/> Loamy <input type="checkbox"/>		
Temperature: Ambient:	60F	Track:	60F
Notes:			

Tires:

Front Tires:	Pro-Line Electrons
Front Compound:	MC
Front Insert:	Pro-Line Closed Cell
Rear Tires:	Pro-Line Positron
Rear Compound:	MC
Rear Insert:	Pro-Line Closed Cell
Wheel (F/R):	#92096 & #9696 Team Associated
Notes:	

Body, Wing, Weight:

Body:	#92087 Team Associated Kit
Wing:	#91741 Team Associated Kit
Wing Angle:	0° <input type="checkbox"/> 3° <input type="checkbox"/> 6° <input checked="" type="checkbox"/>
Chassis Weights:	None <input checked="" type="checkbox"/> 15g <input type="checkbox"/> 30g <input type="checkbox"/> Other <input type="checkbox"/>
Other Weights:	N/A
Total Vehicle Weight:	

Vehicle Comments:

Notes:	#91576 & #91578 Kashima Shock Bodies; #91618 & 91620 Chrome Shock Shafts & #91449 Plastic Shock Caps
---------------	--