

## Front Suspension:

<b>Ride Height:</b>	19 mm
<b>Camber:</b>	-1°
<b>Toe:</b>	+1°
<b>Anti-Roll Bar:</b>	None
<b>Wheelbase Shim:</b>	Front (Arm Back)
<b>Wheel Hex:</b>	#92032 3.5 mm (Kit)
<b>Caster Block:</b>	7° <input type="checkbox"/> 10° <input type="checkbox"/> 13° <input checked="" type="checkbox"/>
<b>Notes:</b>	#92026 Hard Front A-Arms #1363 FT Aluminum Servo Horn, 18.5 mm

**Axle Height:**

+3

+2

+1

0

**Arm Mount A:**

LRC  HRC  1°  0.5°

**Arm Mount B:**

LRC  HRC  1°  0.5°

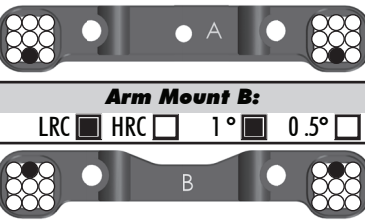

**Bump Steer Spacing:** 1 mm

**Ball Stud Spacing:** 1 mm

**Steering Plate:** #92032 (Kit)

**Ball Stud Spacing:** 1 mm

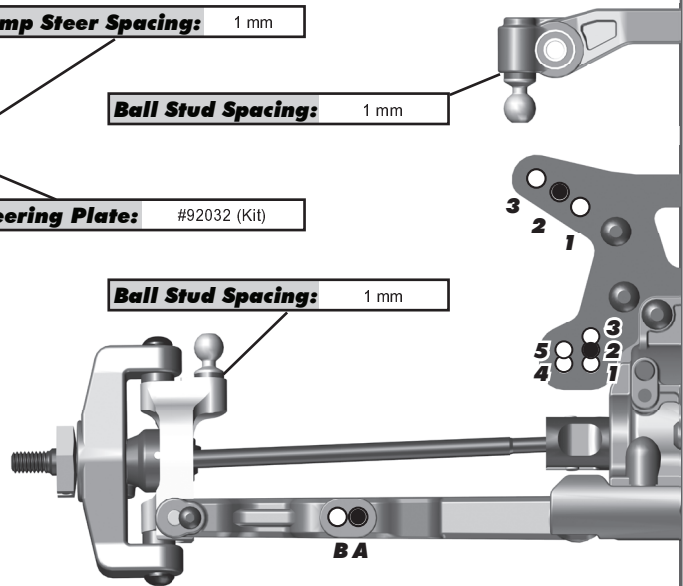

## Rear Suspension:

<b>Ride Height:</b>	20 mm
<b>Camber:</b>	-1°
<b>Anti-Roll Bar:</b>	1.2 mm
<b>Wheelbase Shim:</b>	Front (Arm Back)
<b>Wheel Hex:</b>	#91609 5.0 mm
<b>Hub Spacing:</b>	Forward <input type="checkbox"/> Middle <input checked="" type="checkbox"/> Back <input type="checkbox"/>
<b>Gearbox Shim:</b>	Yes <input checked="" type="checkbox"/> No <input type="checkbox"/>
<b>Chassis Brace:</b>	Short <input type="checkbox"/> Long <input checked="" type="checkbox"/>
<b>Notes:</b>	#92049 Hard Rear Arms

**Arm Mount C:**

LRC  HRC  1°  0.5°

**Arm Mount D:**

LRC  HRC  1°  0.5°

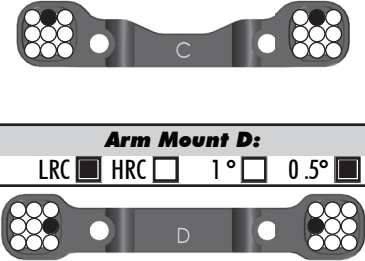

### Rear Hub Link Setting:

**Up**

E C A

D B

**Down**

D

E C A

**Hub Insert:**

+3  +2  +1  0

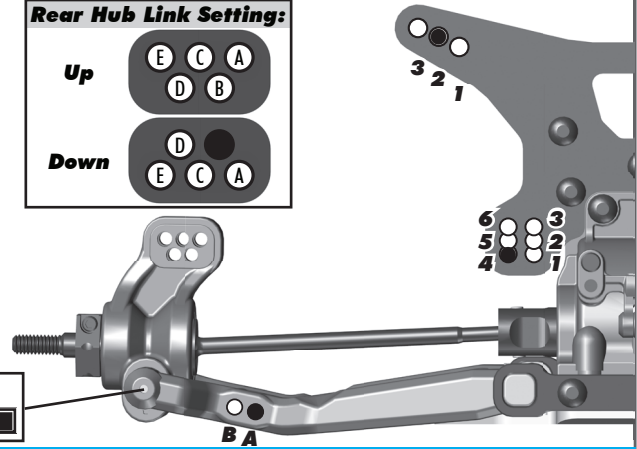

## Electronics:

<b>Radio:</b>	Sanwa M12S	<b>Servo:</b>	#27101 Reedy RT1508
<b>EPA: Throttle:</b>	100 %	<b>Brake:</b>	90 %
<b>ESC:</b>	#27004 Reedy Blackbox 510R		
<b>ESC Settings:</b>	N/A		
<b>Motor:</b>	Reedy M3		
<b>Wind:</b>	5.5	<b>Timing:</b>	20°
<b>Pinion:</b>	#1337 Factory Team 19T	<b>Spur:</b>	81
<b>Battery:</b>	#27305 Reedy Zapper 100C		
<b>Battery Position:</b>	Middle		

## Differential:

<b>Front Fluid:</b>	5,000
<b>Gears:</b>	Plastic <input type="checkbox"/> Metal <input checked="" type="checkbox"/>
<b>Center Fluid:</b>	500,000
<b>Gears:</b>	Plastic <input type="checkbox"/> Metal <input checked="" type="checkbox"/>
<b>Rear Fluid:</b>	5,000
<b>Gears:</b>	Plastic <input type="checkbox"/> Metal <input checked="" type="checkbox"/>
<b>Slipper Clutch:</b>	
<b>Type:</b>	N/A
<b># of Pads:</b>	N/A

## Shocks:

	Front	Rear
<b>Piston:</b>	2 x 1.6 Flat Machined	1 x 1.7 + 2 x 1.8 Flat Machined
<b>Fluid:</b>	37.5 wt	30 wt
<b>Spring:</b>	AE Yellow	AE Gray
<b>Limiters:</b>	1	0
<b>Stroke:</b>	21.0 mm	28.0 mm
<b>Eyelet Length:</b>	Short	Long
<b>Cup Offset:</b>	5 mm	0 mm
<b>Notes:</b>	#91494 Machined Internals, #91493 X-Rings	

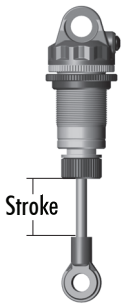

## Track Info:

<b>Size:</b>	Small <input type="checkbox"/> Medium <input type="checkbox"/> Large <input checked="" type="checkbox"/> Extra Large <input type="checkbox"/>		
<b>Surface:</b>	Dirt <input checked="" type="checkbox"/> Carpet <input type="checkbox"/> Astroturf <input type="checkbox"/> Multi Surface <input type="checkbox"/>		
<b>Traction:</b>	Low <input type="checkbox"/> Medium <input checked="" type="checkbox"/> High <input type="checkbox"/> Very High <input type="checkbox"/>		
<b>Moisture:</b>	Dry <input checked="" type="checkbox"/> Damp <input checked="" type="checkbox"/> Wet <input type="checkbox"/>		
<b>Condition:</b>	Indoor <input checked="" type="checkbox"/> Outdoor <input type="checkbox"/> Dusty <input type="checkbox"/> Hard Packed <input checked="" type="checkbox"/> Bumpy <input type="checkbox"/> Grooved <input type="checkbox"/> Smooth <input checked="" type="checkbox"/> Loamy <input type="checkbox"/>		
<b>Temperature: Ambient:</b>	50F	<b>Track:</b>	50F
<b>Notes:</b>	Raining Outside		

## Tires:

<b>Front Tires:</b>	Pro-Line Transistor
<b>Front Compound:</b>	MC
<b>Front Insert:</b>	JConcepts Dirt Tech
<b>Rear Tires:</b>	Pro-Line Positron
<b>Rear Compound:</b>	MC
<b>Rear Insert:</b>	JConcepts Dirt Tech
<b>Wheel (F/R):</b>	#92095 AE 12mm Hex / Pro-Line Hex
<b>Notes:</b>	Reedy Race Spec Additive

## Body, Wing, Weight:

<b>Body:</b>	#92088 Team Associated Kit - Lightweight
<b>Wing:</b>	#91741 Team Associated Kit
<b>Wing Angle:</b>	0° <input type="checkbox"/> 3° <input type="checkbox"/> 6° <input checked="" type="checkbox"/>
<b>Chassis Weights:</b>	20g
	None <input type="checkbox"/> 15g <input type="checkbox"/> 30g <input type="checkbox"/> Other <input checked="" type="checkbox"/>
<b>Other Weights:</b>	N/A
<b>Total Vehicle Weight:</b>	

## Vehicle Comments:

**Notes:** #91576 & #91577 Kashima Shock Bodies; #91449 Plastic Shock Caps