

Front Suspension:

Ride Height:	18 mm
Camber:	-1°
Toe:	+1°
Anti-Roll Bar:	1.2 mm (Green)
Wheelbase Shim:	Front (Arm Back)
Wheel Hex:	#91609 5 mm
Caster Block:	7° <input type="checkbox"/> 10° <input checked="" type="checkbox"/> 13° <input type="checkbox"/>
Notes:	#92026 Hard Front A-Arms #1363 FT Aluminum Servo Horn, 18.5 mm #92023 FT LRC Arm Mount B, Brass

Axle Height:

+3

+2

+1

0

Bump Steer Spacing: 2 mm

Ball Stud Spacing: 2 mm

Steering Plate: #91679 B6

Ball Stud Spacing: 1 mm

Arm Mount A:

LRC HRC 1° 0.5°



Arm Mount B:

LRC HRC 1° 0.5°

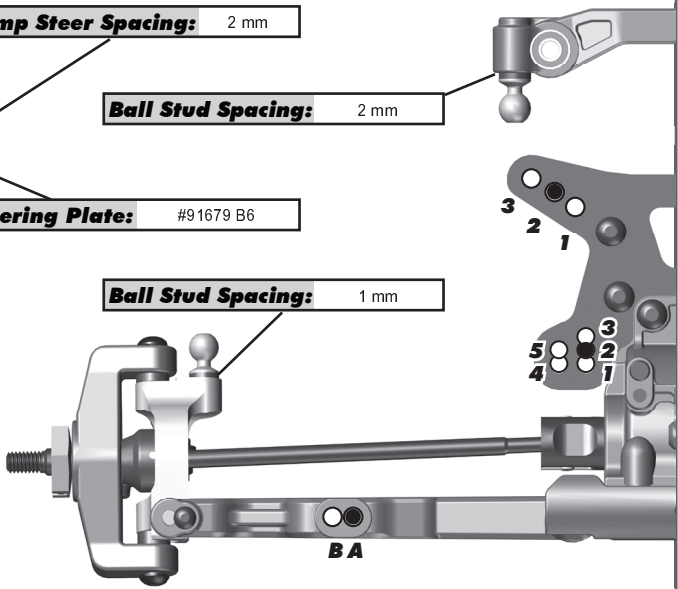
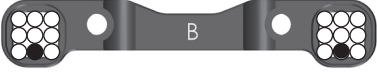

Rear Suspension:

Ride Height:	18 mm
Camber:	-1°
Anti-Roll Bar:	1.3 mm (White)
Wheelbase Shim:	3 mm Rear (Arms Forward)
Wheel Hex:	#91609 5.0 mm
Hub Spacing:	Forward <input type="checkbox"/> Middle <input checked="" type="checkbox"/> Back <input type="checkbox"/>
Gearbox Shim:	Yes <input type="checkbox"/> No <input checked="" type="checkbox"/>
Chassis Brace:	Short <input checked="" type="checkbox"/> Long <input type="checkbox"/>
Notes:	7mm Added To Top Shock Standoff #92049 B64 Hard Rear Arms (Moved Forward 2mm) Camber Link Mounted On The Front Of The Tower

Arm Mount C:

LRC HRC 1° 0.5°



Arm Mount D:

LRC HRC 1° 0.5°



Rear Hub Link Setting:

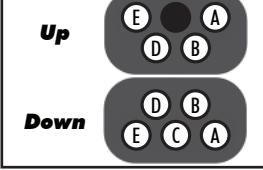

Hub Insert:

+3 +2 +1 0

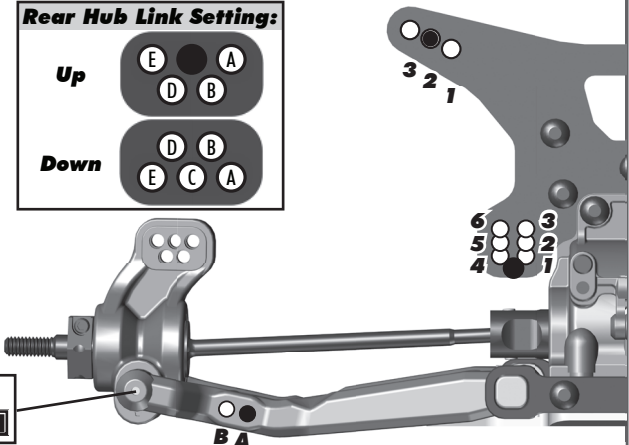

Electronics:

Radio:	Sanwa M12S	Servo:	#27101 Reedy RT1508
EPA: Throttle:	100 %	Brake:	90 %
ESC:	#27004 Reedy Blackbox 510R		
ESC Settings:	See Setup Sheet		
Motor:	Reedy M3		
Wind:	5.5	Timing:	20°
Pinion:	#1337 Factory Team 19T	Spur:	81
Battery:	#27303 Reedy Zapper 5800 mAh 70C		
Battery Position:	Forward		

Differential:

Front Fluid:	10,000
Gears:	Plastic <input type="checkbox"/> Metal <input checked="" type="checkbox"/>
Center Fluid:	200,000
Gears:	Plastic <input type="checkbox"/> Metal <input checked="" type="checkbox"/>
Rear Fluid:	10,000
Gears:	Plastic <input type="checkbox"/> Metal <input checked="" type="checkbox"/>
Slipper Clutch:	
Type:	N/A
# of Pads:	N/A

Shocks:

	Front	Rear
Piston:	2 x 1.6 Flat	2 x 1.7 Flat
Fluid:	37.5 wt	30 wt
Spring:	X-Gear Orange	X-Gear Red
Limiters:	1	0
Stroke:	22.5 mm	28 mm
Eyelet Length:	Long	Long
Cup Offset:	5 mm	0 mm
Notes:	#91494 Machined Internals, #91493 X-Rings	



Track Info:

Size:	Small <input type="checkbox"/> Medium <input checked="" type="checkbox"/> Large <input type="checkbox"/> Extra Large <input type="checkbox"/>		
Surface:	Dirt <input type="checkbox"/> Carpet <input type="checkbox"/> Astroturf <input type="checkbox"/> Multi Surface <input type="checkbox"/>		
Traction:	Low <input type="checkbox"/> Medium <input type="checkbox"/> High <input checked="" type="checkbox"/> Very High <input type="checkbox"/>		
Moisture:	Dry <input checked="" type="checkbox"/> Damp <input type="checkbox"/> Wet <input type="checkbox"/>		
Condition:	Indoor <input checked="" type="checkbox"/> Outdoor <input type="checkbox"/> Dusty <input type="checkbox"/> Hard Packed <input checked="" type="checkbox"/> Bumpy <input type="checkbox"/> Grooved <input checked="" type="checkbox"/> Smooth <input type="checkbox"/> Loamy <input type="checkbox"/>		
Temperature: Ambient:	55F	Track:	55F
Notes:			

Tires:

Front Tires:	Pro-Line Electron
Front Compound:	MC
Front Insert:	Pro-Line Closed Cell
Rear Tires:	Pro-Line Positron
Rear Compound:	MC
Rear Insert:	Pro-Line Closed Cell
Wheel (F/R):	Pro-Line
Notes:	

Body, Wing, Weight:

Body:	Pro-Line Elite
Wing:	Pro-Line Airforce
Wing Angle:	0° <input type="checkbox"/> 3° <input type="checkbox"/> 6° <input checked="" type="checkbox"/>
Chassis Weights:	None <input checked="" type="checkbox"/> 15g <input type="checkbox"/> 30g <input type="checkbox"/> Other <input type="checkbox"/>
Other Weights:	
Total Vehicle Weight:	

Vehicle Comments:

Notes: #91576 & 91578 FT Fox Shock Bodies; #91618 & #91620 FT Chrome Shock Shafts; #91449 Plastic Shock Caps