

Front Suspension:

Ride Height:	14.5 mm
Camber:	-1°
Toe:	+1°
Anti-Roll Bar:	1.8 mm (Orange)
Wheelbase Shim:	Front (Arms Back)
Wheel Hex:	#91609 5 mm
Caster Block:	7° <input type="checkbox"/> 10° <input type="checkbox"/> 13° <input type="checkbox"/>
Notes:	#92026 Hard Front A-Arms #1363 FT Aluminum Servo Horn, 18.5 mm #92103 FT Aluminum Steering Rack

Axle Height:

+3

+2

+1

0

Arm Mount A:

LRC HRC 1° 0.5°

Arm Mount B:

LRC HRC 1° 0.5°

Bump Steer Spacing: 0 mm

Ball Stud Spacing: 1 mm

Steering Plate: #92032 (Kit)

Ball Stud Spacing: 1 mm

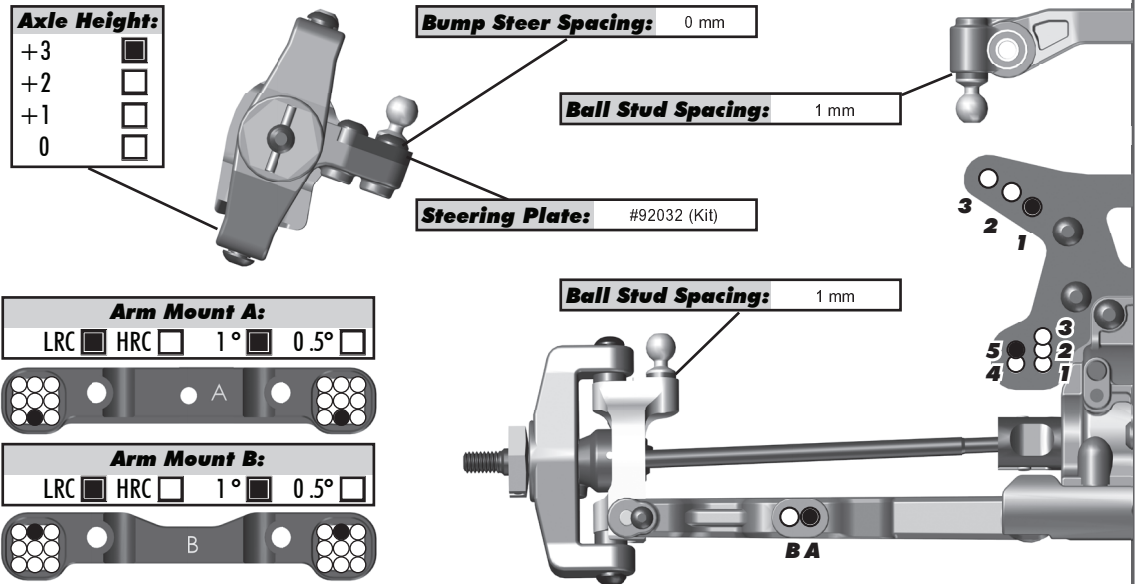

Rear Suspension:

Ride Height:	15 mm
Camber:	-1°
Anti-Roll Bar:	1.8 mm (Orange)
Wheelbase Shim:	Front (Arms Back)
Wheel Hex:	#91609 5.0 mm
Hub Spacing:	Forward <input type="checkbox"/> Middle <input checked="" type="checkbox"/> Back <input type="checkbox"/>
Gearbox Shim:	Yes <input checked="" type="checkbox"/> No <input type="checkbox"/>
Chassis Brace:	Short <input type="checkbox"/> Long <input checked="" type="checkbox"/>
Notes:	#92049 Hard Rear Arms

Arm Mount C:

LRC HRC 1° 0.5°

Arm Mount D:

LRC HRC 1° 0.5°

Rear Hub Link Setting:

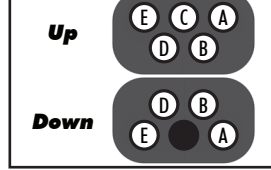

Hub Insert:

+3 +2 +1 0

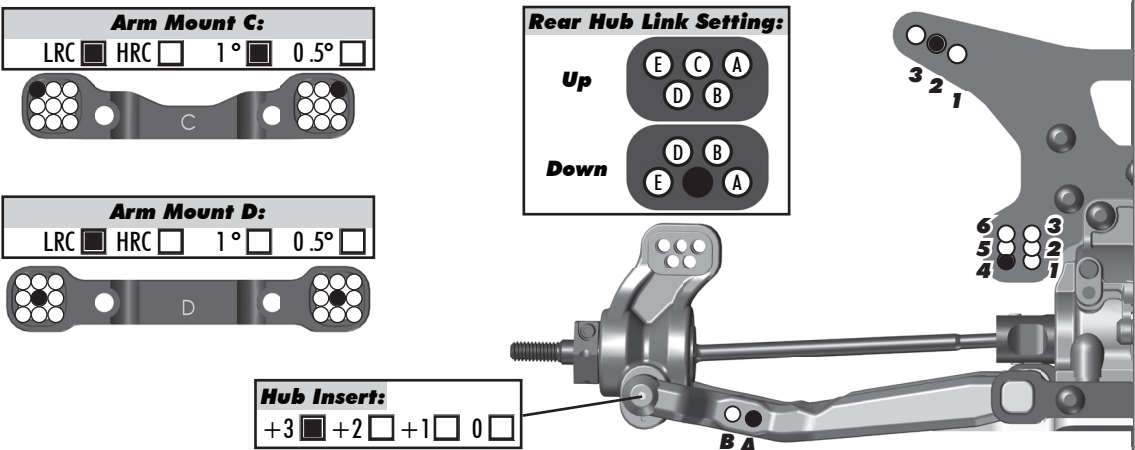

Electronics:

Radio:	Sanwa M12S	Servo:	#27101 Reedy RT1508
EPA: Throttle:	100 %	Brake:	90 %
ESC:	#27004 Reedy Blackbox 510R		
ESC Settings:	N/A		
Motor:	Reedy M3		
Wind:	5.5	Timing:	20°
Pinion:	#1337 Factory Team 19T	Spur:	81
Battery:	#27307 Reedy Zapper 5800 mAh 70C		
Battery Position:	Forward		

Differential:

Front Fluid:	10,000
Gears:	Plastic <input type="checkbox"/> Metal <input checked="" type="checkbox"/>
Center Fluid:	N/A
Gears:	Plastic <input type="checkbox"/> Metal <input type="checkbox"/>
Rear Fluid:	10,000
Gears:	Plastic <input type="checkbox"/> Metal <input checked="" type="checkbox"/>
Slipper Clutch:	
Type:	Team Associated VTS
# of Pads:	3 Pads - LCF

Shocks:

	Front	Rear
Piston:	2 x 1.6 Flat	2 x 1.9 Flat
Fluid:	37.5 wt	35 wt
Spring:	AE Purple	AE Gray
Limiters:	4	0
Stroke:	20 mm	27.5 mm
Eyelet Length:	Long	Long
Cup Offset:	5 mm	0 mm
Notes:	#91494 Machined Internals, #91493 X-Rings	

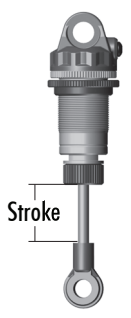

Track Info:

Size:	Small <input type="checkbox"/> Medium <input checked="" type="checkbox"/> Large <input type="checkbox"/> Extra Large <input type="checkbox"/>		
Surface:	Dirt <input type="checkbox"/> Carpet <input type="checkbox"/> AstroTurf <input checked="" type="checkbox"/> Multi Surface <input type="checkbox"/>		
Traction:	Low <input type="checkbox"/> Medium <input checked="" type="checkbox"/> High <input type="checkbox"/> Very High <input type="checkbox"/>		
Moisture:	Dry <input type="checkbox"/> Damp <input checked="" type="checkbox"/> Wet <input type="checkbox"/>		
Condition:	Indoor <input checked="" type="checkbox"/> Outdoor <input type="checkbox"/> Dusty <input type="checkbox"/> Hard Packed <input type="checkbox"/> Bumpy <input type="checkbox"/> Grooved <input type="checkbox"/> Smooth <input checked="" type="checkbox"/> Loamy <input type="checkbox"/>		
Temperature: Ambient:	70F	Track:	70F
Notes:	AstroTurf laid over on itself and got slick in spots		

Tires:

Front Tires:	Schumacher Cut Stagers
Front Compound:	Yellow
Front Insert:	Schumacher
Rear Tires:	Schumacher Mini Dart
Rear Compound:	Yellow
Rear Insert:	Schumacher
Wheel (F/R):	Team Associated
Notes:	Spec Tire

Body, Wing, Weight:

Body:	JConcepts S2 Lightweight
Wing:	JConcepts Aero Long Cord
Wing Angle:	0° <input type="checkbox"/> 3° <input type="checkbox"/> 6° <input checked="" type="checkbox"/>
Chassis Weights:	None <input checked="" type="checkbox"/> 15g <input type="checkbox"/> 30g <input type="checkbox"/> Other <input type="checkbox"/>
Other Weights:	
Total Vehicle Weight:	

Vehicle Comments:

Notes: #91576 & #91577 Kashima Shock Bodies; #91449 Plastic Shock Caps;