

Front Suspension:

Reset Forms

Ride Height:	14 mm
Camber:	-1*
Toe:	0*
Anti-Roll Bar:	1.0mm
Arm Type:	#91872 Gullwing, Carbon
Tower Type:	#91880 B6.3, Gullwing
Wheel Hex:	#91682 5mm, Aluminum
Steering Block:	4mm
Caster Block Insert:	2.5*
Bulkhead Type:	#91898 FT Steel -2.5* / +2.5*
Kick-Up Angle:	25*
Notes:	#91983 FT Aluminum Steering Bellcranks

Bump Steer Spacing:	0
Steering Plate:	#91902 FT HT +1
Steering Stop Spacing:	0mm
Caster Block Spacing:	1mm
Axle Height:	+3 <input type="checkbox"/> +2 <input type="checkbox"/> +1 <input type="checkbox"/> +0 <input type="checkbox"/>

Ball Stud Spacing:	1mm
Steering Bellcrank Position:	Up <input type="checkbox"/> Down <input checked="" type="checkbox"/>
Ball Stud Spacing:	1mm

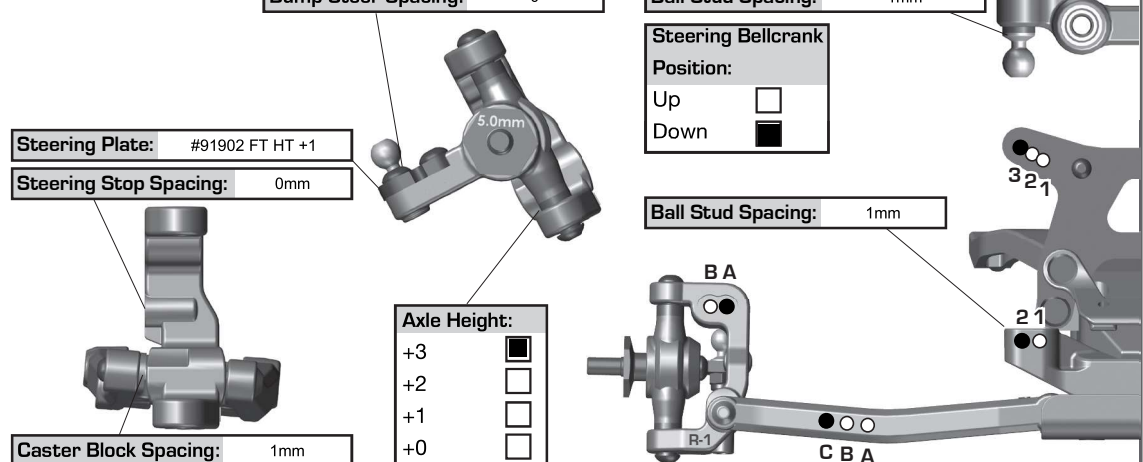

Rear Suspension:

Ride Height:	14 mm
Camber:	-1*
Anti-Roll Bar:	1.4mm
Arm Type:	#91873 73mm, Carbon
Tower Type:	#91881 B6.3
Arm Spacing:	2mm In Front of Arm
Wheel Hex:	#91609 FT Clamping Hex, 5mm
Shock Mounting Position:	Front of Arm <input checked="" type="checkbox"/> Rear of Arm <input type="checkbox"/>
Hub Spacing:	Fwd <input type="checkbox"/> Mid <input checked="" type="checkbox"/> Back <input type="checkbox"/>
CVA Bone Length:	#91860 69mm
CVA Axle Type:	#91859 +2mm
Notes:	#91888 FT Rear Ballstud Mount +2mm

C Mount:	Aluminum <input checked="" type="checkbox"/> Brass <input type="checkbox"/>
D Mount:	Aluminum <input checked="" type="checkbox"/> Brass <input type="checkbox"/>

Axle Height:	▼0 3▲ +3 ▼1 2▲ +2 ▲1 2▼ +1 ▲0 3▼ +0
--------------	--

Camber Link Spacing:	2mm
Ball Stud Spacing:	2mm
Ball Stud Spacing:	2mm w/ #91859

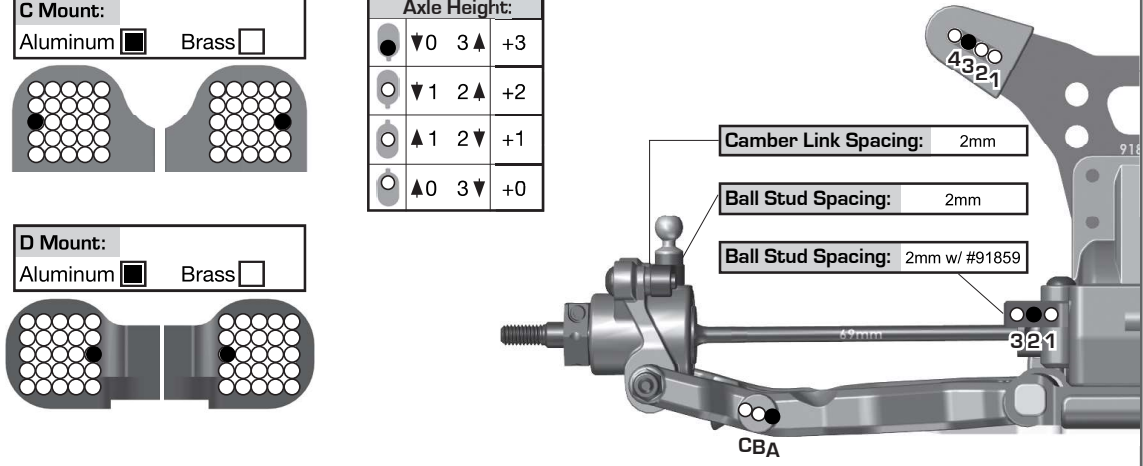

Electronics:

Radio:	Sanwa M12S	Servo:	Protek 170SBL
EPA: Throttle:	100 %	Brake:	100 %
ESC:	Muchmore Fleta Pro V2		
ESC Settings:	Power Level 2, Drive Frequency 8k, Turbo 35		
Motor / Wind:	Muchmore Fleta ZX V2 6.0	Timing:	20*
Pinion:	#1339 FT 21T	Spur:	78
Battery:	Muchmore 4200mah 7.6v Ultra Thin Shorty		
Battery Position:	Back 1 <input type="checkbox"/> 2 <input type="checkbox"/> 3 <input type="checkbox"/> 4 <input type="checkbox"/> 5 <input checked="" type="checkbox"/> Forward		
Battery Weight:	None		

Drivetrain:

Transmission:	Laydown: <input checked="" type="checkbox"/> Layback: <input type="checkbox"/>
Differential:	Ball Diff: <input type="checkbox"/>
Height:	3 Gear Diff: <input checked="" type="checkbox"/>
Diff Setting:	N/A
Notes:	Muchmore 15k w/ 2 Planet Gears

Slipper Clutch:

Type:	#91802 & #91806 FT Vented Slipper
# of Pads:	2 x #92285 FT Octalock LCF
Setting:	Front Tires Almost Lift Off Ground

Shocks:

	Front	Rear
Piston:	#91933, 2 x 1.7mm	#91934, 2 x 1.8mm
Thickness:	2.5mm	2.5mm
Fluid:	Muchmore 500	Muchmore 450
Spring:	#91945, Orange	#91951, Yellow
Limiters:	Int: 0 Ext: 0	Int: 0 Ext: 0
Stroke:	21.8mm	27.6mm
Eyelet Length:	+2mm	+4mm
Cup Offset:	5mm	0mm
Notes:	#91494 Machined Shock Spacers, #10501 1up X-Rings	



Track Info:

Size:	Small <input type="checkbox"/> Medium <input type="checkbox"/> Large <input type="checkbox"/> Extra Large <input checked="" type="checkbox"/>
Surface:	Dirt <input type="checkbox"/> Carpet <input type="checkbox"/> Astroturf <input checked="" type="checkbox"/> Multi Surface <input type="checkbox"/>
Traction:	Low <input type="checkbox"/> Medium <input type="checkbox"/> High <input type="checkbox"/> Very High <input checked="" type="checkbox"/>
Moisture:	Dry <input type="checkbox"/> Damp <input checked="" type="checkbox"/> Wet <input type="checkbox"/>
Condition:	Indoor <input checked="" type="checkbox"/> Outdoor <input type="checkbox"/> Dusty <input type="checkbox"/> Hard Packed <input type="checkbox"/> Bumpy <input type="checkbox"/> Grooved <input type="checkbox"/> Smooth <input type="checkbox"/> Loamy <input type="checkbox"/>
Temperature:	Ambient: 75* Track: 75*
Notes:	

Tires:

Front Tires:	JConcepts Fuzz Bite
Front Compound:	Standard
Front Insert:	None
Rear Tires:	JConcepts Nessi
Rear Compound:	Standard
Rear Insert:	Standard
Wheel (F/R):	JConcepts
Notes:	5mm Trimmed Off Rear Foam

Body, Weight:

Body:	JConcepts B6 S2 LW
Front Wing:	#91866 B6.2
Rear Wing:	#0197 JConcepts Carpet High Clearance
Wing Angle:	6*
Chassis Length:	#91968 B6.4 +3mm
Servo Weights:	#91747 FT Steel
Electronic Weights:	#91977 FT Steel
Total Vehicle Weight:	1556

Vehicle Comments: 1up Racing Gold Titanium Turnbuckle Set #740601, 1up Racing Competition Bearing Set #450001, 1up Racing Chassis Protector #300012