

For Immediate Release: April 11, 2022

RC10B6.4D Team Kit

#90035



ELECTRIC ■ OFF ROAD ■ 1:10 SCALE ■ 2 WHEEL DRIVE ■ KIT

Champions by Design

1:10 scale 2WD off road has been Team Associated's signature class since the release of the RC10 in 1984. The Team Associated RC10 buggy series has won 13 of the 18 I.F.M.A.R. World Championships contested, yet we never rest on our laurels. As tires, motors, batteries, and tracks evolve, Team Associated adapts and improves with every iteration of the RC10. With the RC10B6.4 project, engineers had the goals of improving jumping and landing, updating the steering feel to be "easy to drive fast," and making the buggy corner faster on high-grip carpet and clay.

The RC10B6.4 platform continues the trend of offering two kit configurations. Both kits include the next generation 13mm diameter big-bore shocks and springs to provide the ultimate in damping and stability. The larger diameter shocks reduce pressure inside the shock and minimize the effects of the shaft displacement. This allows the buggy to feel like it's riding on an invisible cloud when you hit harsh jumps and landings. The chassis, front end, and steering system is optimized for running reduced caster and kickup, which excels on high speed, high grip surfaces. An updated steering system with adjustable height bellcranks helps racers minimize bumpsteer. In addition, the front suspension is equipped with new -1mm kingpin offset steering and caster blocks for smooth and predictable front end feel through the entire throw. The -1mm design pushes the steering pivot closer the center of the front tire, keeping the front end flat through the entire steering throw.

Both buggies are equipped with a new chassis layout and ESC weights that allow forward mounted electronics closer to the servo, as well as additional forward battery placement over the previous model. All of the new weight tuning options allow for more high-speed stability and on-power steering on high grip carpet. The **#90034 RC10B6.4 Team Kit** will be the buggy of choice for high grip carpet or turf track surfaces with the new +3mm chassis layout, 11mm Octalock LCF slipper clutch setup, steel ESC and servo weights, and included anti-roll bars front and rear. The **#90035 RC10B6.4D Team Kit** includes a new dirt-length chassis, 19mm Octalock LCF slipper clutch setup, aluminum ESC weight, layback gearbox, and an optimized dirt kit setup.

Both cars share many great features, such as an easy-access rear differential, new wide pivot rear aluminum arm mounts for use with 73mm arms and 69mm CVA bones, and updated carbon fiber shock towers with molded protective covers. The setups and tuning parts remain interchangeable between the two configurations. Both versions come with the speed, durability and lineage expected of a true champion. Choose the configuration that suits your track and conquer the competition!

HIGHLIGHTS

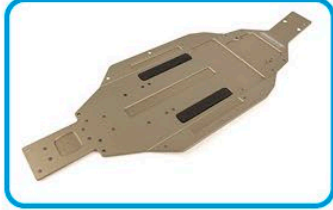

New dirt-length aluminum chassis with 22.5° kickup to complement updated front end geometry

RC10 B6.4D TEAM KIT



New caged thrust bearing for ball differential



Octalock spur gear and 19mm Octalock LCF pads

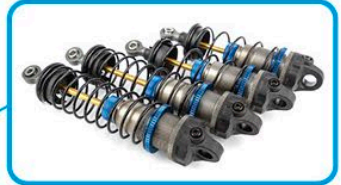

New 13mm big bore threaded aluminum shocks and springs with machined shock pistons and improved handling

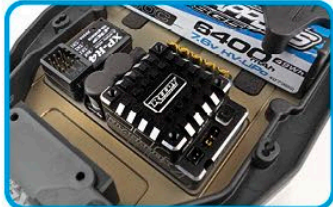

New aluminum RC10B6.4 ESC weight shifted forward with a wider footprint to fit electronics for more forward weight bias



New chassis side rails with 3 optional fan mount locations to choose from



-1mm kingpin offset steering and caster block set for smoother steering through the entire wheel throw



20°/22.5° and 25° molded bulkheads included for a complete range of caster and kickup options

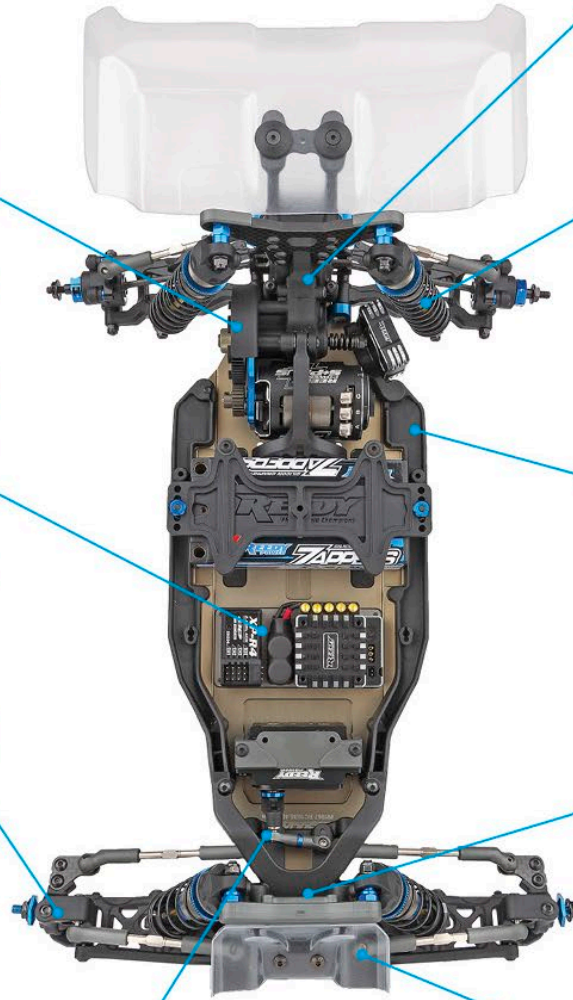

New adjustable height steering bellcrank and rack system for optimized bumpsteer at all ride heights and caster angles



New front ballstud mount, top plate, and front wing mount to account for the kickup angle change

Due to ongoing R&D, photos may not match final kit. Vehicle shown on these pages equipped with items NOT included in kit: Reedy motor, battery, ESC, servo, receiver, wheels, tires, fan, and pinion gear. Assembly and painting required.

MORE FEATURES

- New 13mm big-bore threaded aluminum shocks and springs with machined shock pistons for improved bump and jump handling
- New dirt length aluminum chassis with 22.5° kick-up to complement updated front-end geometry and with new shape to reduce chassis scrub with the track surface
- 20°/22.5° and 25° molded bulkheads included for a complete range of caster and kickup options
- New adjustable height steering bellcrank and rack system for optimized bumpsteer at all ride heights and caster angles
- New -1mm kingpin offset steering and caster block set for smoother and more predictable steering through the entire wheel throw
- New aluminum RC10B6.4 ESC mounting tray shifted forward in the chassis and with a wider footprint to fit electronics, resulting in a further forward weight bias
- New front ballstud mount, top plate, and front wing mount to account for the kickup angle change
- New chassis side rails with three fan mount locations to choose from depending on chassis length and transmission used
- New caged thrust bearing for ball differential
- New cab-forward design RC10B6.4 bodyshell offered in standard (kit) and lightweight (optional) thickness

SPECIFICATIONS

| | |
|------------------------------|--------------------------|
| Scale | 1:10 |
| Power | Electric |
| Length (with wing) | 390mm (15.4") |
| Width | Varies* |
| Weight (chassis only) | 821g (1.81lbs) |
| Wheelbase | 279-283mm (10.98-11.14") |
| Transmission Ratio | 2.60:1 |

*Final width, length, and height will vary based on electronics tire configuration, wing position, and vehicle setup.

ITEMS NEEDED TO COMPLETE

- 1:10 scale electric motor and electronic speed control (Motor: Reedy #27402 or #27441. ESC: Reedy #27005)
- 7.4V-7.6V 2S LiPo with "shorty" battery dimensions (standard or low-profile height) (Reedy #27382)
- Battery charger (suited for, and particular to, one of the batteries mentioned above) (Reedy #27203)
- 2-channel surface transmitter with its batteries, 2-channel receiver, and steering servo (Reedy #27119)
- Lexan® specific spray paint for body
- 1:10 scale off-road buggy wheels and tires
- 4x AA batteries (Reedy #302)
- Other helpful items: Silicone Shock Fluid, Silicone Diff Fluid, Body Scissors (#1737), Reamer/Hole Punch, FT Wrench Set (#1519), Turnbuckle Wrench (#1114), Hobby Knife, Needle Nose Pliers, Wire Cutters, Soldering Iron, Calipers or a Precision Ruler

CATALOG INFORMATION

| UPC | Part No. | Description | MAP | MSRP | Available |
|--------------|----------|--------------------|----------|----------|------------|
| 784695900356 | 90035 | RC10B6.4D Team Kit | \$389.99 | \$569.99 | April 2022 |

Download all zipped photos here: <https://bit.ly/3jptFlt> (25.2MB). Link is active for 30 days.



21062 Bake Pkwy
Lake Forest CA 92630
www.AssociatedElectrics.com

