

## Front Suspension:

Reset Forms

<b>Ride Height:</b>	19 mm
<b>Camber:</b>	-1°
<b>Toe:</b>	0° (Tierod Gap = 27.2 mm)
<b>Arm Type:</b>	#91674 Gullwing, Hard
<b>Tower Type:</b>	#91768 Gullwing
<b>Caster Block Insert:</b>	5°
<b>Steering Block:</b>	4 mm
<b>Bulkhead Type:</b>	#91658 FT Aluminum
<b>Kick-Up Angle:</b>	25°
<b>Wheel Hex:</b>	#91683 Titanium
<b>Notes:</b>	#1366 FT Aluminum Servo Horn, 25T #91667 Plastic Steering Rack & Bellcranks

<b>Anti Roll Bar:</b>	White (0.8mm) <input type="checkbox"/>
	Gray (0.9mm) <input type="checkbox"/>
	Blue (1.0mm) <input type="checkbox"/>
	Other: <input type="checkbox"/>

**Bump Steer Spacing:** 0 mm

<b>Axle Height:</b>	+3 <input type="checkbox"/>
	+2 <input checked="" type="checkbox"/>
	+1 <input type="checkbox"/>
	0 <input type="checkbox"/>

**Ball Stud Spacing:** 0 mm

**Steering Plate:** #91680 +1

**Steering Stop Spacing:** 0 mm

**Ball Stud Spacing:** 1 mm

**Caster Block Spacing:** 1 mm

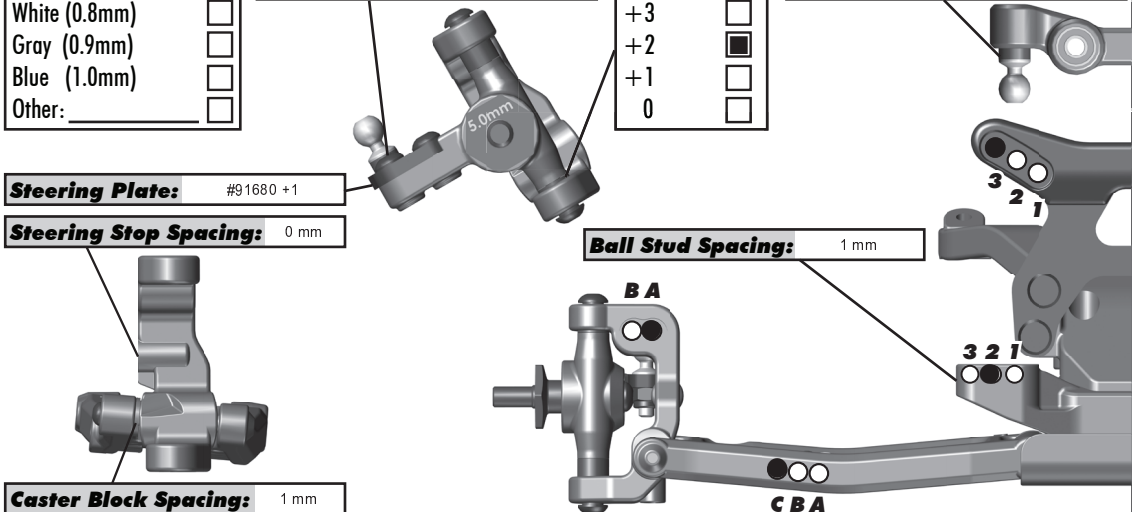

## Rear Suspension:

<b>Ride Height:</b>	19 mm
<b>Camber:</b>	-1°
<b>Tower Type:</b>	#91769 Standard
<b>Wheel Hex:</b>	6.0 mm
<b>CVA Bone Length:</b>	#91437 67 mm
<b>CVA Pin Location:</b>	Towards Hex
<b>Hub Spacing:</b>	Forward <input type="checkbox"/> Middle <input checked="" type="checkbox"/> Back <input type="checkbox"/>
<b>Shock Mounting Position:</b>	Front of Arm <input checked="" type="checkbox"/> Rear of Arm <input type="checkbox"/>
<b>Notes:</b>	#91760 FT Aluminum Hubs #91777 B6.1 Rear Arm, Standard

<b>Anti Roll Bar:</b>	White (1.2mm) <input type="checkbox"/>
	Gray (1.3mm) <input type="checkbox"/>
	Blue (1.4mm) <input type="checkbox"/>
	Other: <input type="checkbox"/>

**Rear Hub Link Setting:**

Plastic Hub  Aluminum Hub  Ball Stud Spacing: 2 mm

Up: 
 Down:

**C Mount Inserts:** 1°  0.5°

Aluminum  Brass

**D Mount Inserts:** 1°  0.5°

Aluminum  Brass

**Hub Insert:**

+3  +2  +1  0

**Ball Stud Spacing:** 4 mm

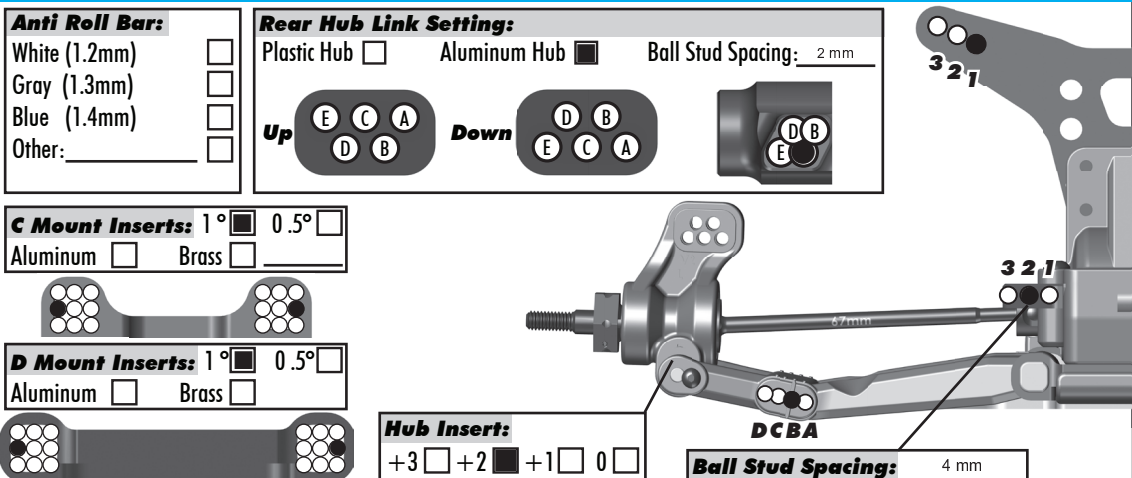

## Electronics:

<b>Radio:</b>	Futaba 7PX	<b>Servo:</b>	Savox 1258-TG
<b>EPA: Throttle:</b>	100 %	<b>Brake:</b>	92 %
<b>ESC:</b>	Hobbywing XR10G2 Elite		
<b>ESC Settings:</b>	See Baseline Setup Sheet		
<b>Motor:</b>	Hobbywing G3		
<b>Wind:</b>	7.5T	<b>Timing:</b>	30°
<b>Pinion:</b>	22T	<b>Spur:</b>	78
<b>Battery:</b>	ProTek 5800mAh + #27304 Reedy Under Battery Weight 22g		
<b>Battery Position:</b>	4F		

## Drivetrains:

<b>Transmission:</b>	<b>Laydown:</b> <input checked="" type="checkbox"/>
<b>3 Gear:</b> <input checked="" type="checkbox"/>	<b>Layback:</b> <input type="checkbox"/>
<b>4 Gear:</b> <input type="checkbox"/>	<b>Stand Up:</b> <input type="checkbox"/>
<b>Differential:</b>	<b>Ball Diff:</b> <input checked="" type="checkbox"/>
<b>Height:</b> 1	<b>Gear Diff:</b> <input type="checkbox"/>
<b>Notes:</b>	

## Slipper Clutch:

**Type:** #91802 & 91806 B6.1 Vented Slipper Hubs

**# of Pads:** 2 x #91197 FT LCF Slipper Pads

## Shocks:

	Front	Rear
<b>Piston:</b>	1x1.6+1x1.7 Flat Machined	2 x 1.7 Flat Machined
<b>Fluid:</b>	#5432 32.5 wt	#5422 30 wt
<b>Spring:</b>	#91329 V1 Gray	#91337 V1 White
<b>Limiters:</b>	0	0
<b>Stroke:</b>	24.0 mm	28.5 mm
<b>Eyelet Length:</b>	Long	Long
<b>Cup Offset:</b>	5 mm	5 mm
<b>Notes:</b>	#91494 Machined Shock Spacers V2; #91493 FT X-Rings	



## Track Info:

<b>Size:</b>	Small <input type="checkbox"/> Medium <input checked="" type="checkbox"/> Large <input type="checkbox"/> Extra Large <input type="checkbox"/>		
<b>Surface:</b>	Dirt <input checked="" type="checkbox"/> Carpet <input type="checkbox"/> Astroturf <input type="checkbox"/> Multi Surface <input type="checkbox"/>		
<b>Traction:</b>	Low <input type="checkbox"/> Medium <input type="checkbox"/> High <input checked="" type="checkbox"/> Very High <input type="checkbox"/>		
<b>Moisture:</b>	Dry <input checked="" type="checkbox"/> Damp <input type="checkbox"/> Wet <input type="checkbox"/>		
<b>Condition:</b>	Indoor <input checked="" type="checkbox"/> Outdoor <input type="checkbox"/> Dusty <input type="checkbox"/> Hard Packed <input checked="" type="checkbox"/>		
	Bumpy <input type="checkbox"/> Grooved <input type="checkbox"/> Smooth <input type="checkbox"/> Loamy <input type="checkbox"/>		
<b>Temperature: Ambient:</b>	55F	<b>Track:</b>	55F
<b>Notes:</b>			

## Tires:

<b>Front Tires:</b>	JConcepts Ellipse
<b>Front Compound:</b>	Silver
<b>Front Insert:</b>	JConcepts Dirt Tech
<b>Rear Tires:</b>	JConcepts Ellipse
<b>Rear Compound:</b>	Silver
<b>Rear Insert:</b>	JConcepts Dirt Tech
<b>Wheel (F/R):</b>	JConcepts Mono
<b>Notes:</b>	

## Body, Wing, Weight:

<b>Body:</b>	JConcepts F2 Lightweight
<b>Wing:</b>	JC Lower Front Wing / JC Carpet Aero
<b>Wing Angle:</b>	0° <input type="checkbox"/> 3° <input type="checkbox"/> 6° <input checked="" type="checkbox"/>
<b>Servo Weights:</b>	#91761 FT Graphite Servo Plate
	None <input type="checkbox"/> Aluminum <input type="checkbox"/> Steel <input type="checkbox"/> Other <input checked="" type="checkbox"/>
<b>Electronic Weights:</b>	#91746 FT Aluminum ESC Weight
	None <input type="checkbox"/> Aluminum <input checked="" type="checkbox"/> Steel <input type="checkbox"/> Other <input type="checkbox"/>
<b>Total Vehicle Weight:</b>	1550g

## Vehicle Comments:

**Notes:** #91755 Ti Screw Kit (only used above chassis); #91652 Side Rails, Standard; #91616 & 91620 Chrome Shock Shafts; #91576 & 91578 Fox Shock Bodies;